

### DRX\_ANT

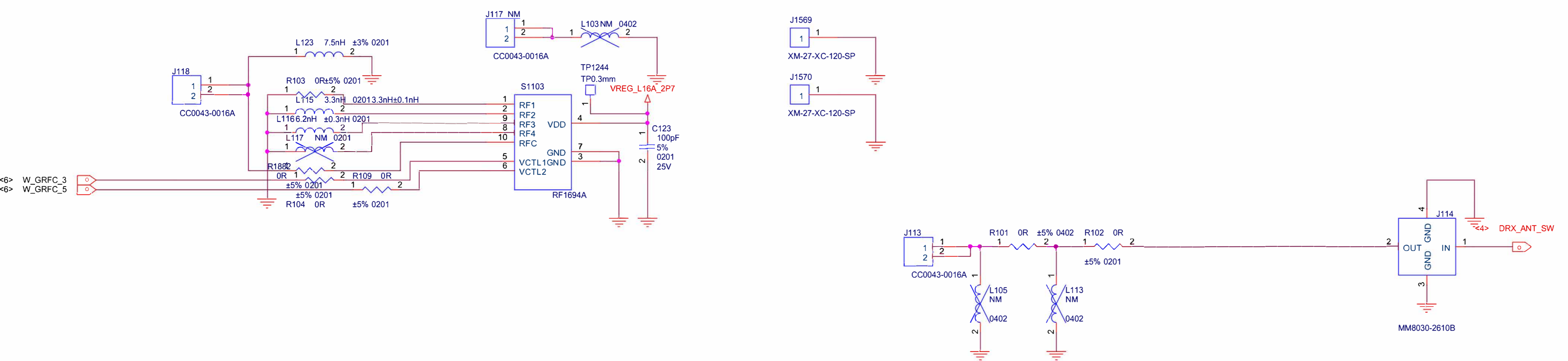

# MMMB PA

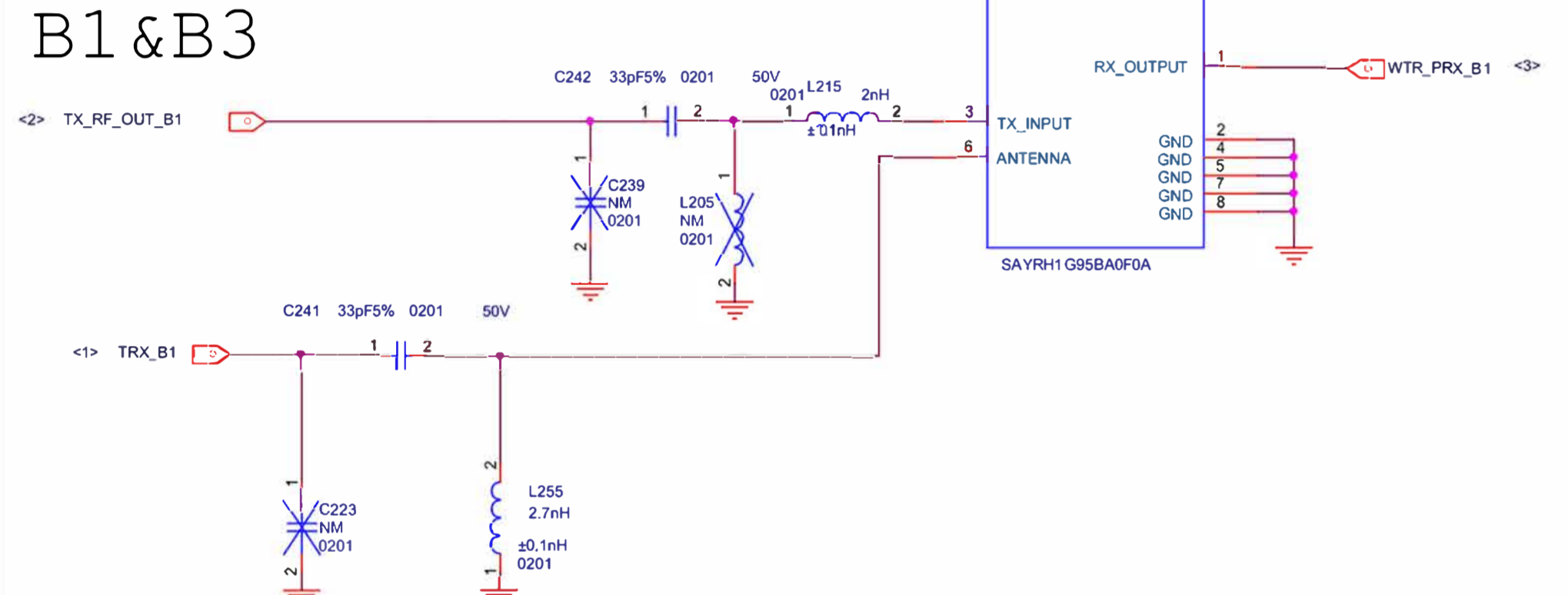
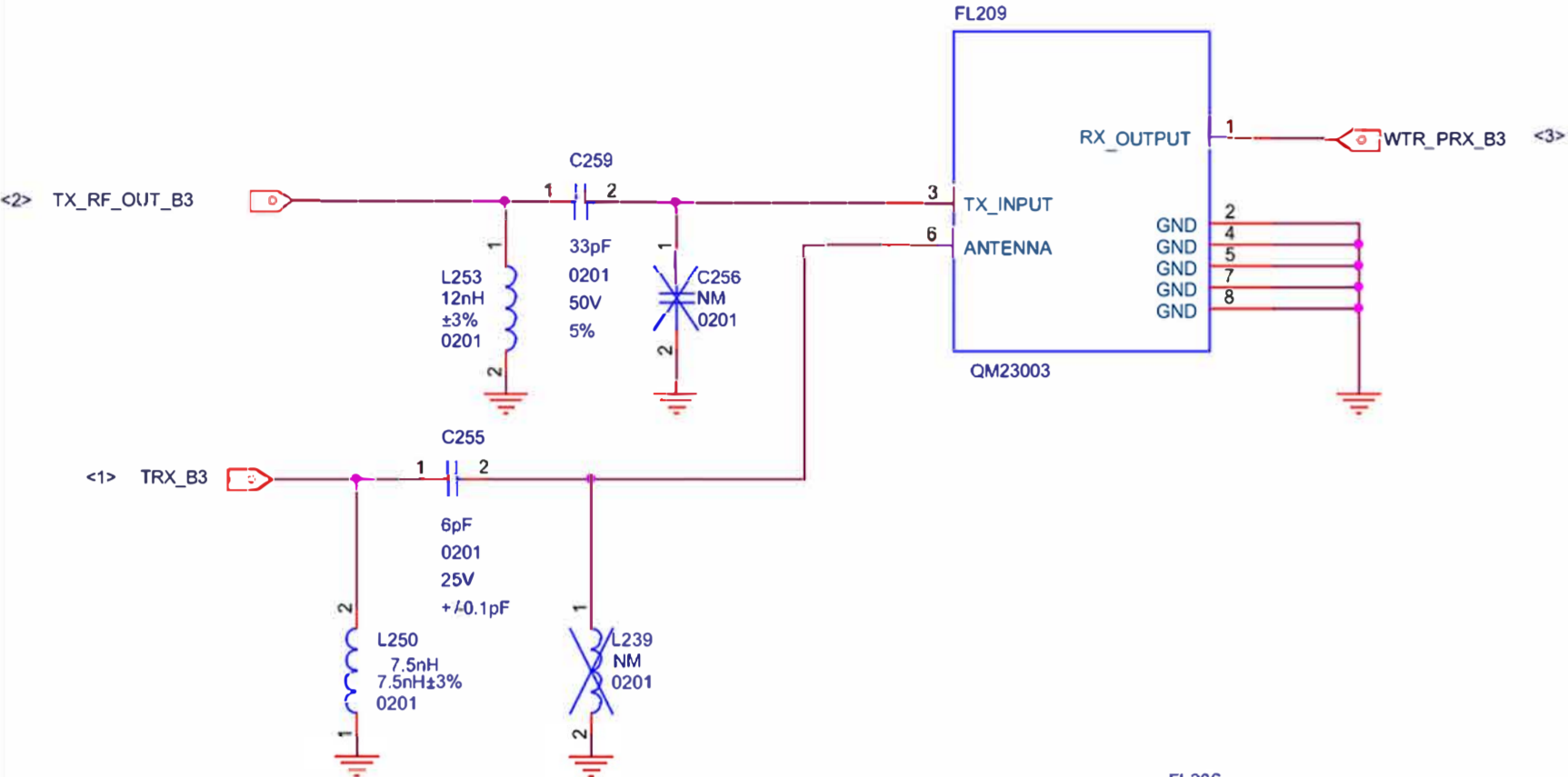
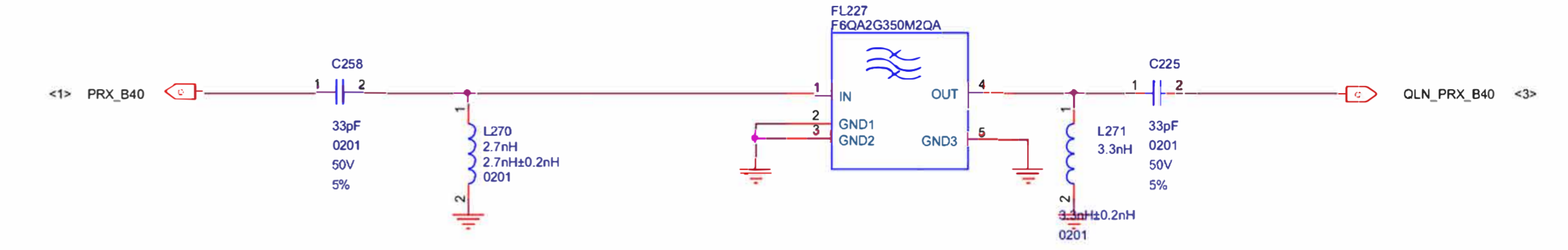
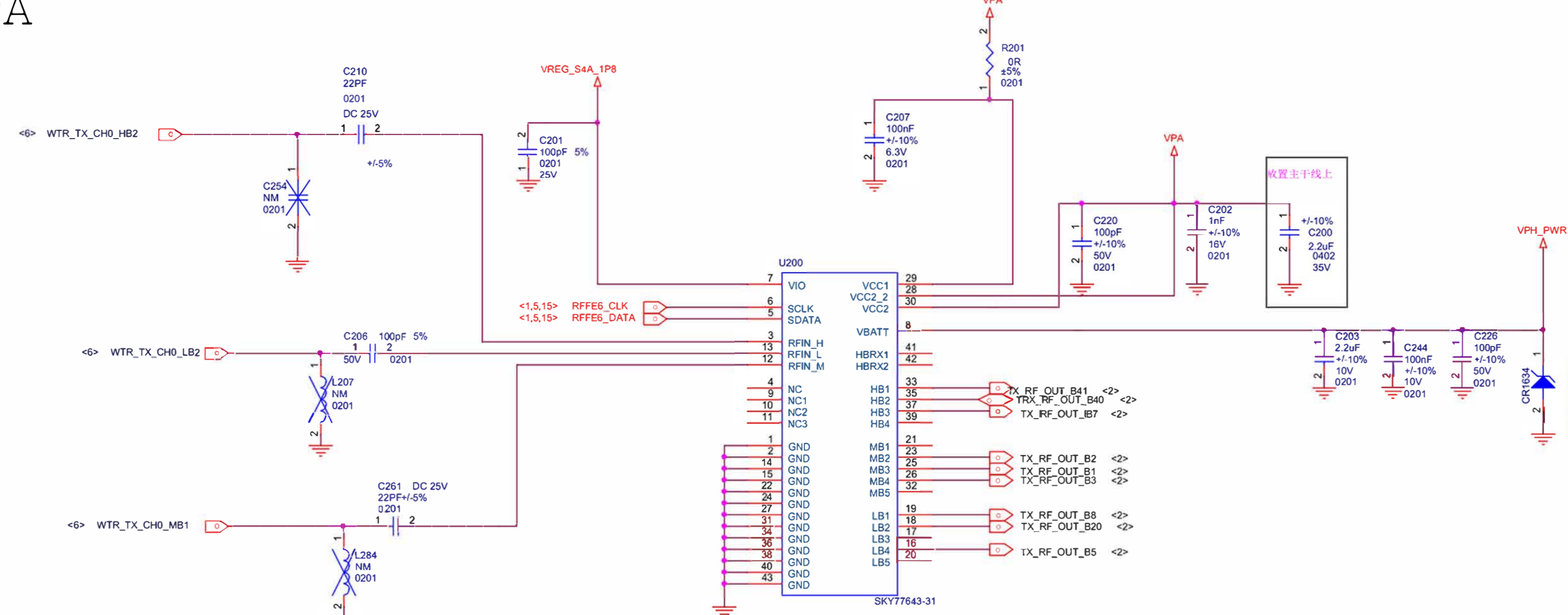

## B40

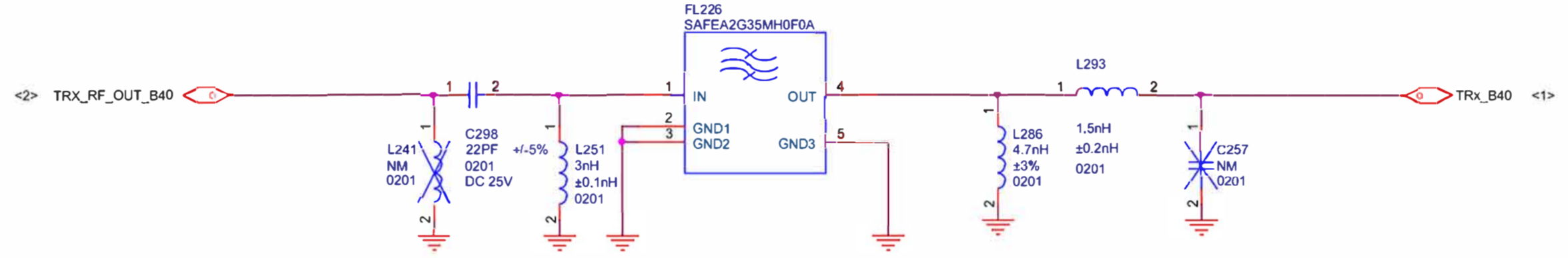

## TX B41

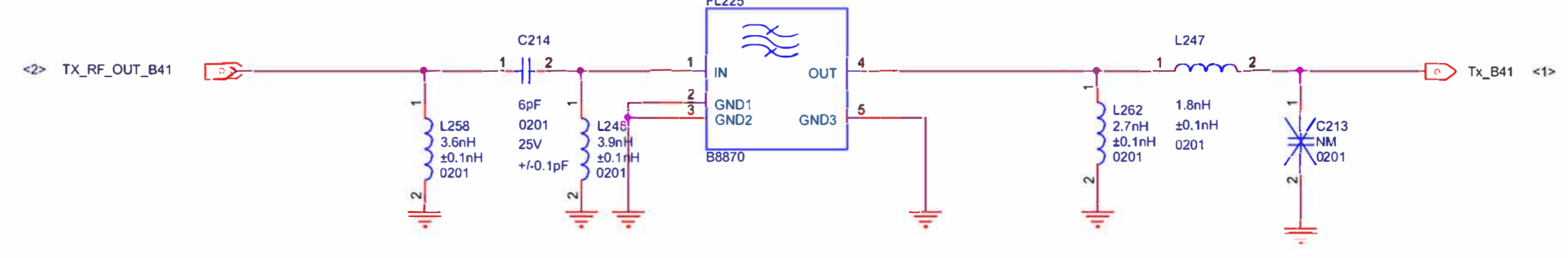

## PRX B41

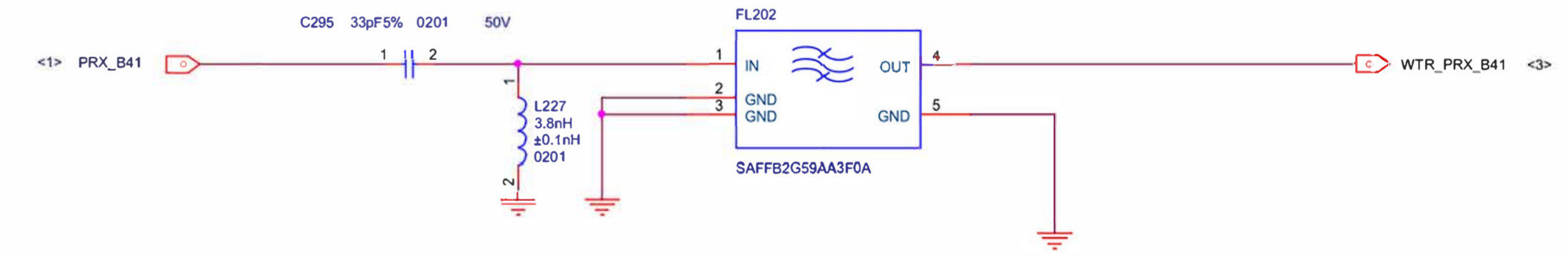

## B2&B5&B8

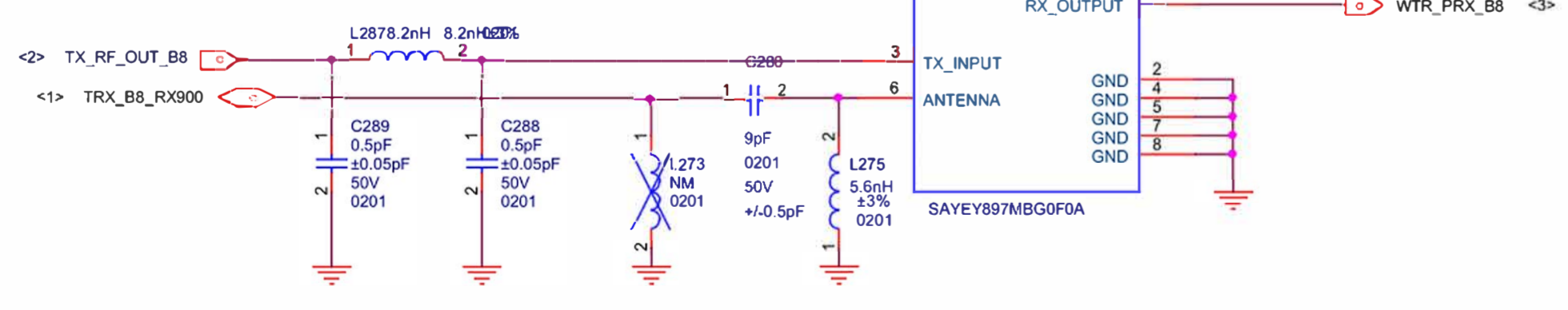
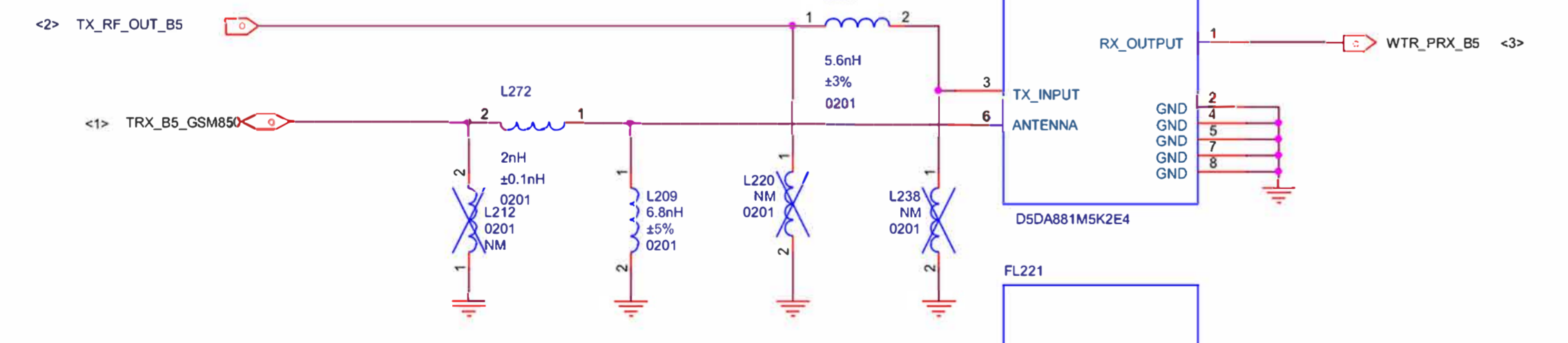
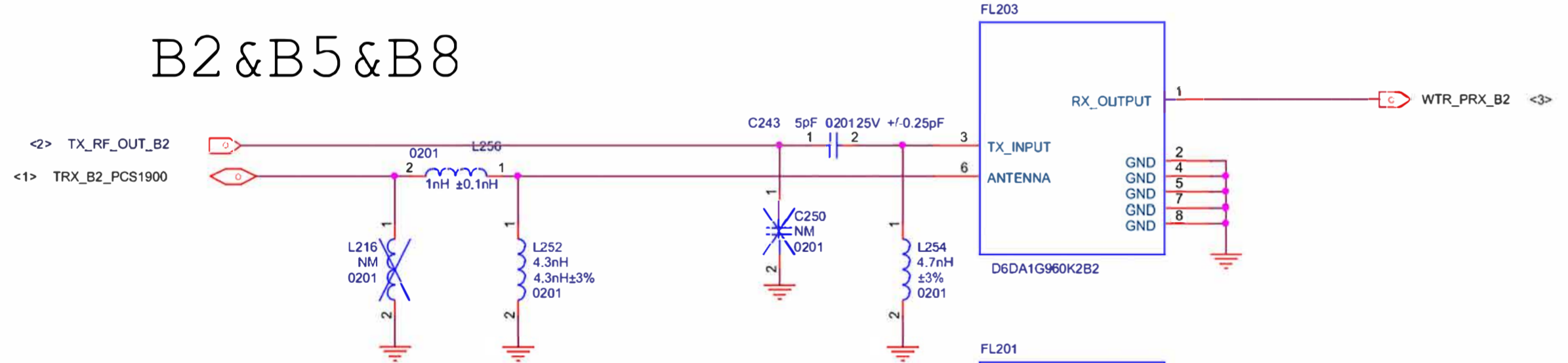

## TX B20

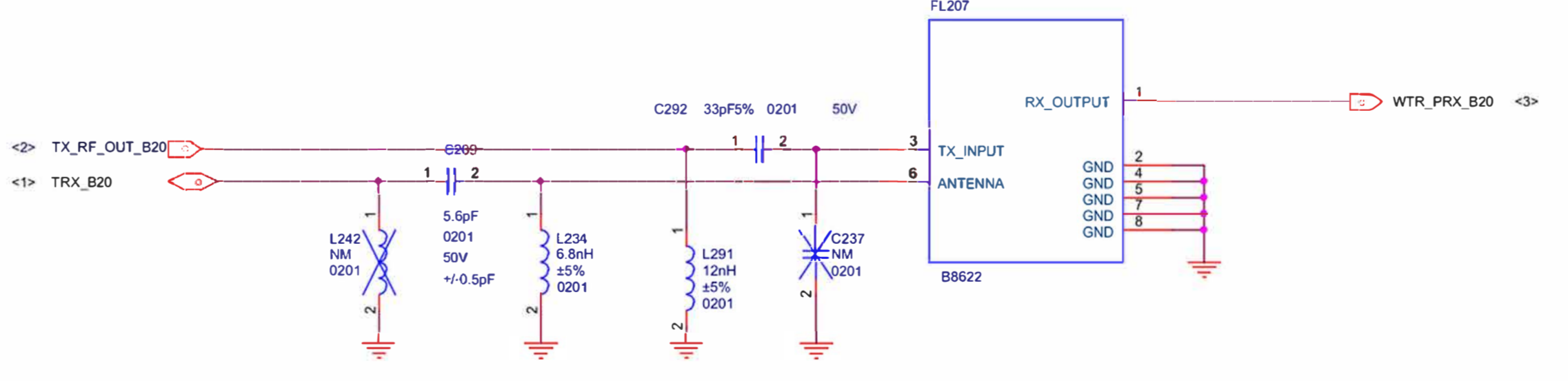

## B7

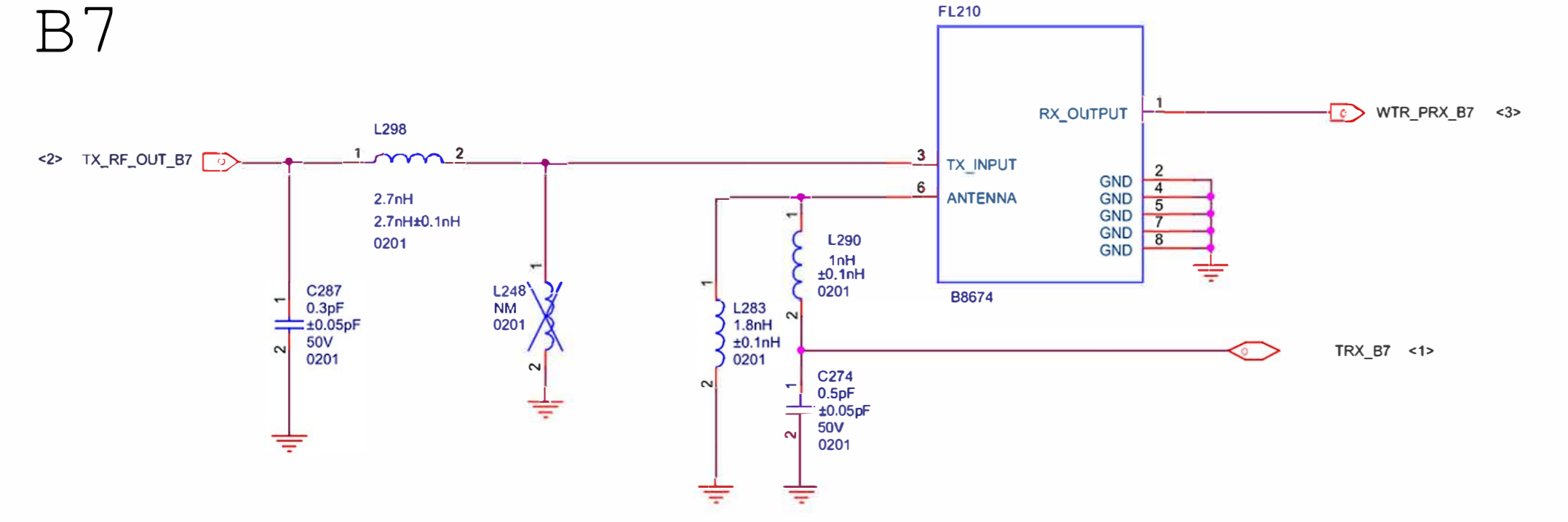

## Thermal

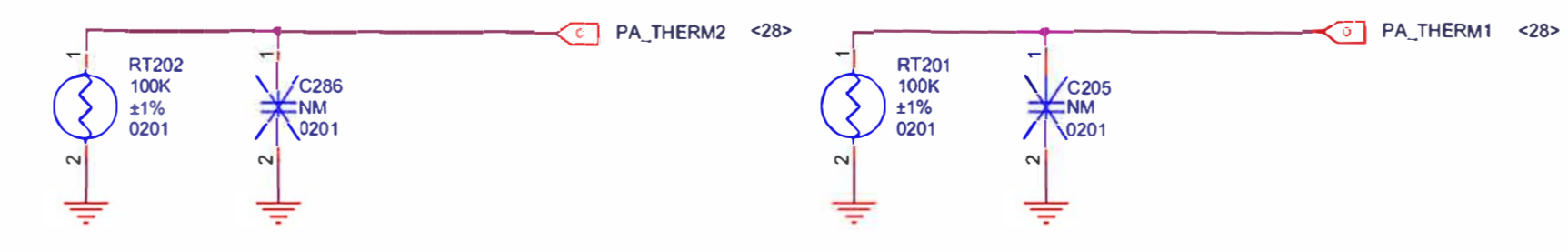

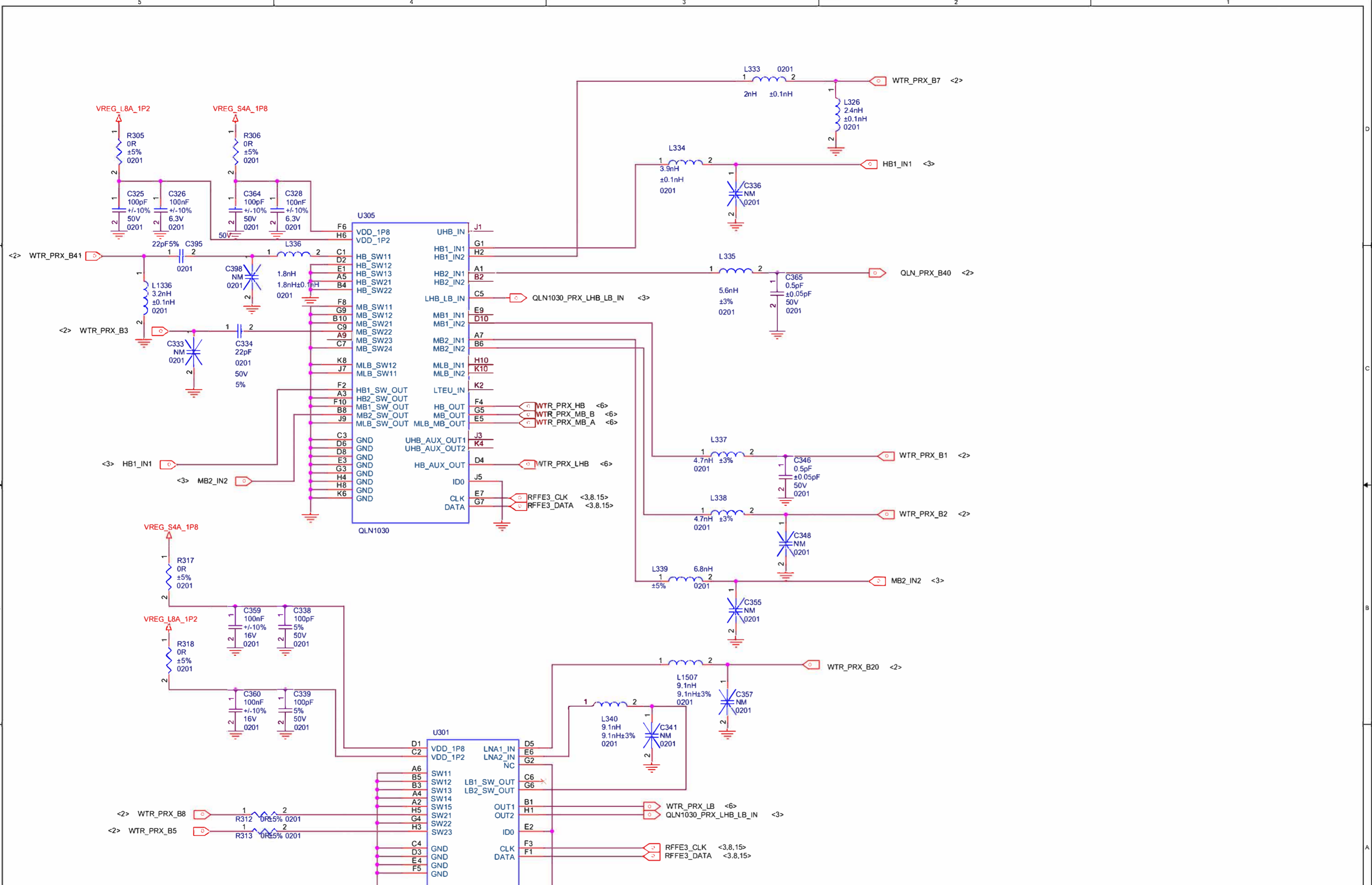

Title		E10	
Size	Document Number	Rev	
A3	BAND7&39&40&41	P0	
Date:	Friday, May 11, 2018	Sheet	3 of 41

# DRX

## DRX B41

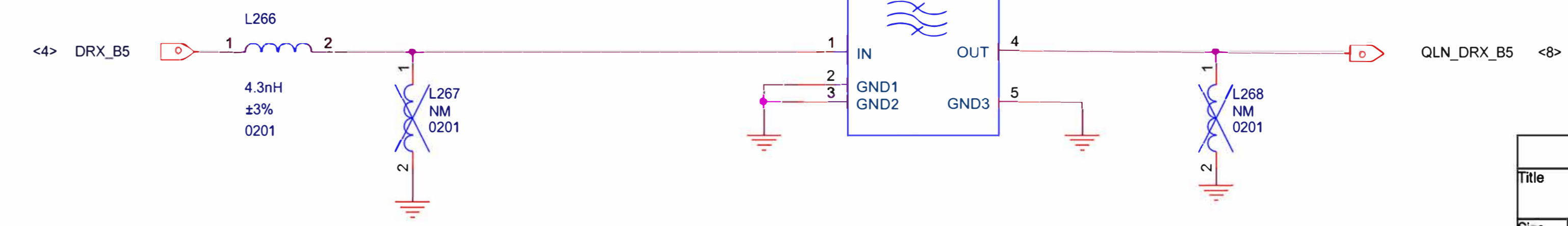
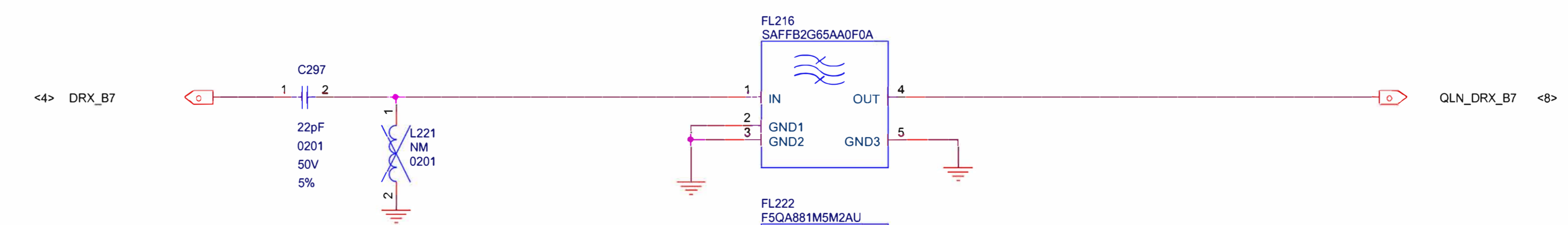
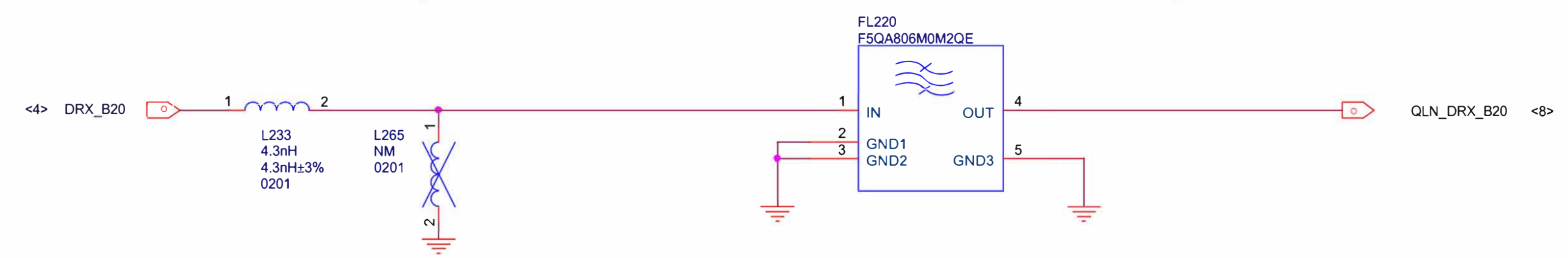
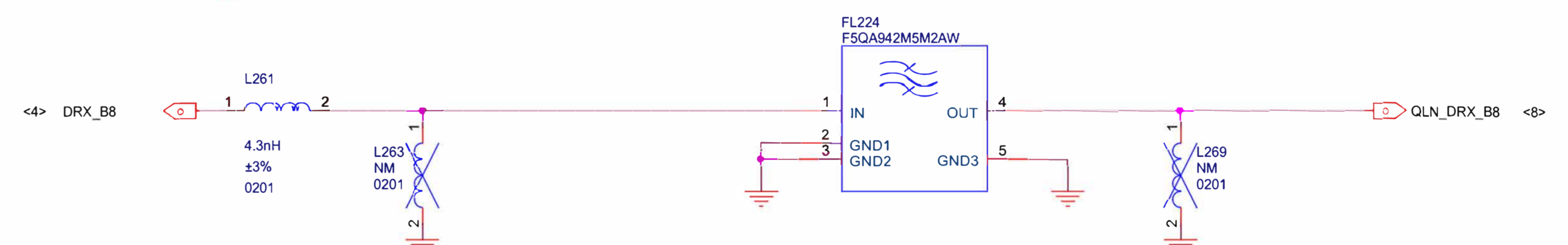
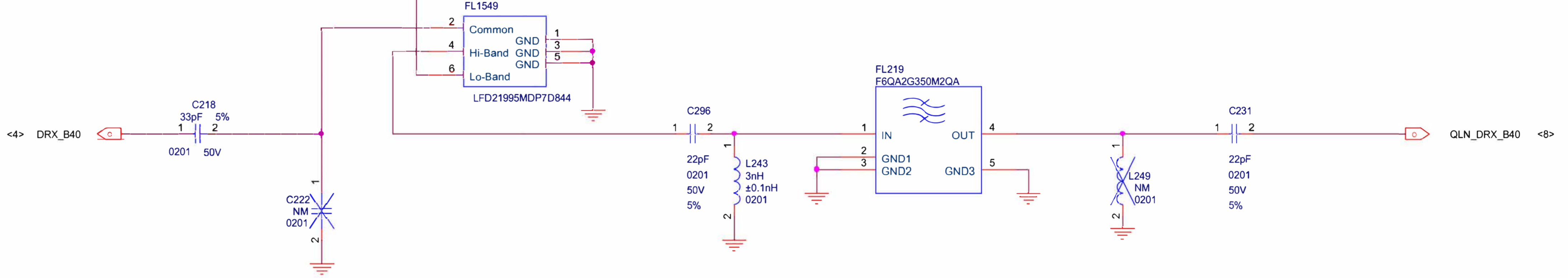
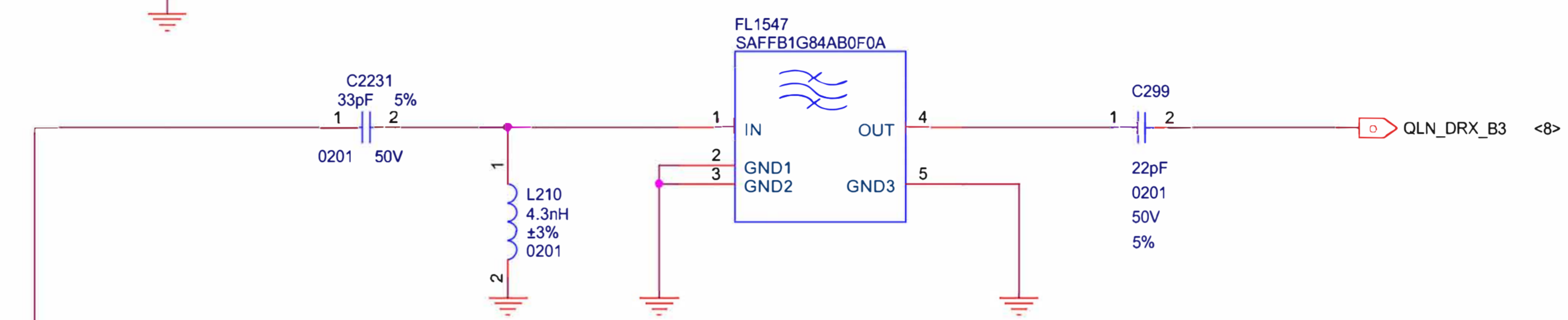
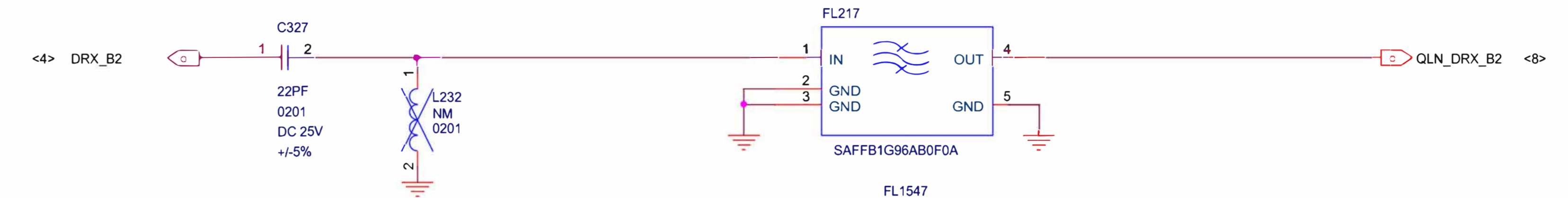
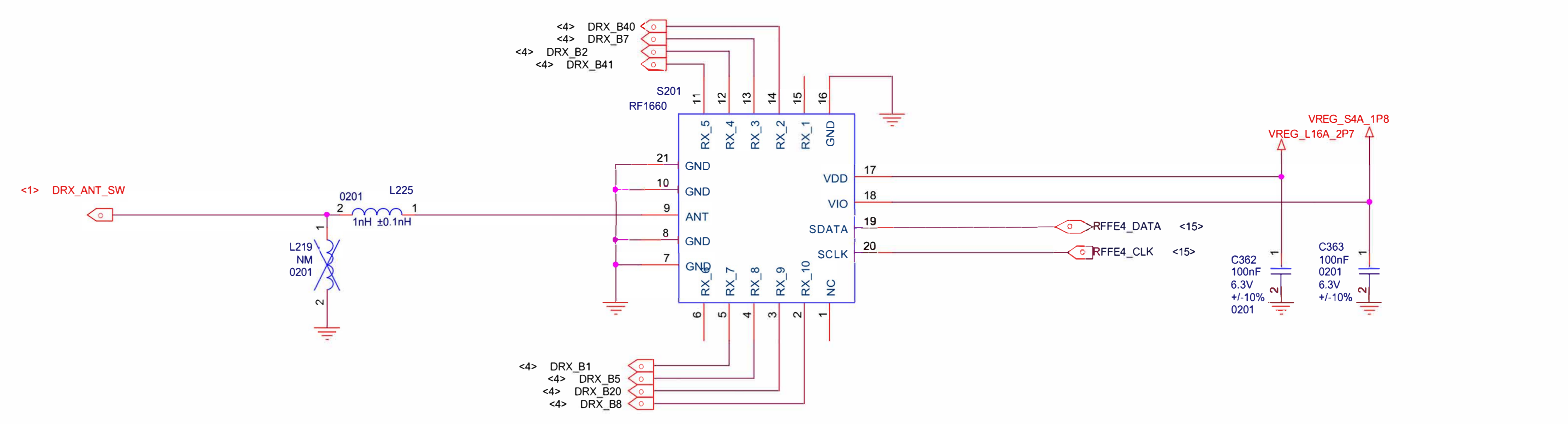
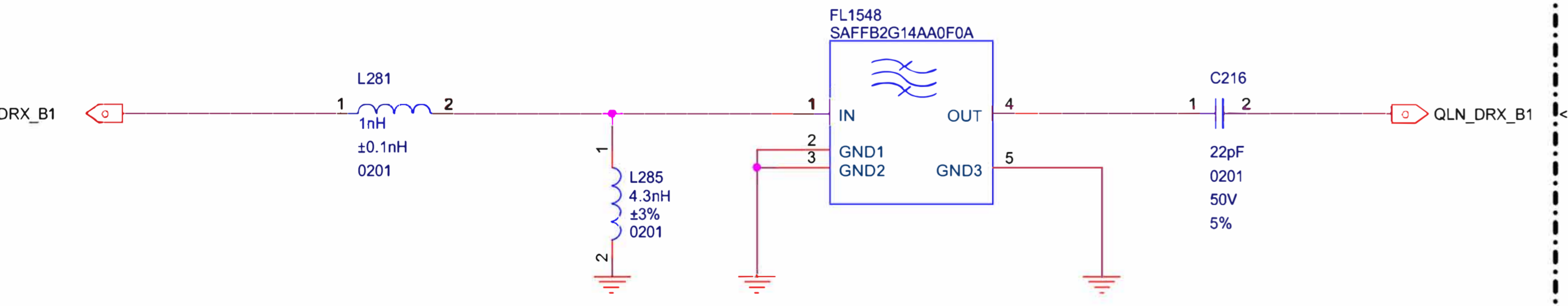
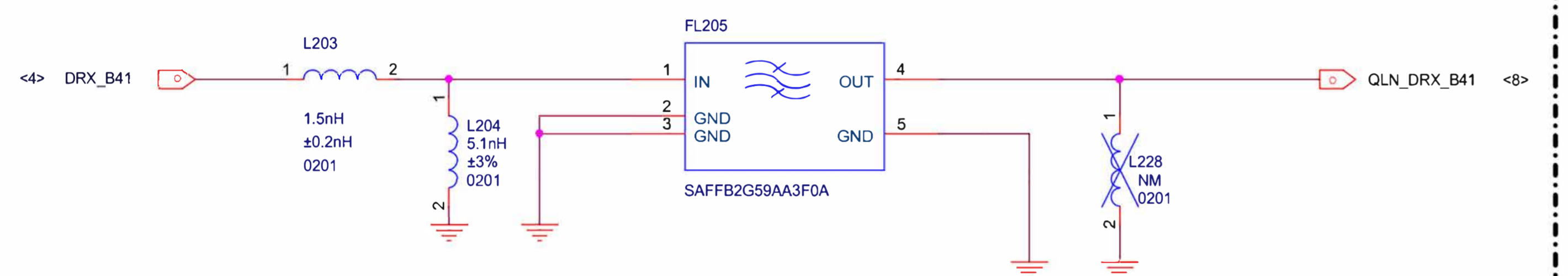

Title			E10
Size	Document Number	Rev	
A2	FILTERS&GSM1800&DRX_B	P0	
Date:	Friday, May 11, 2018	Sheet	4 of 41

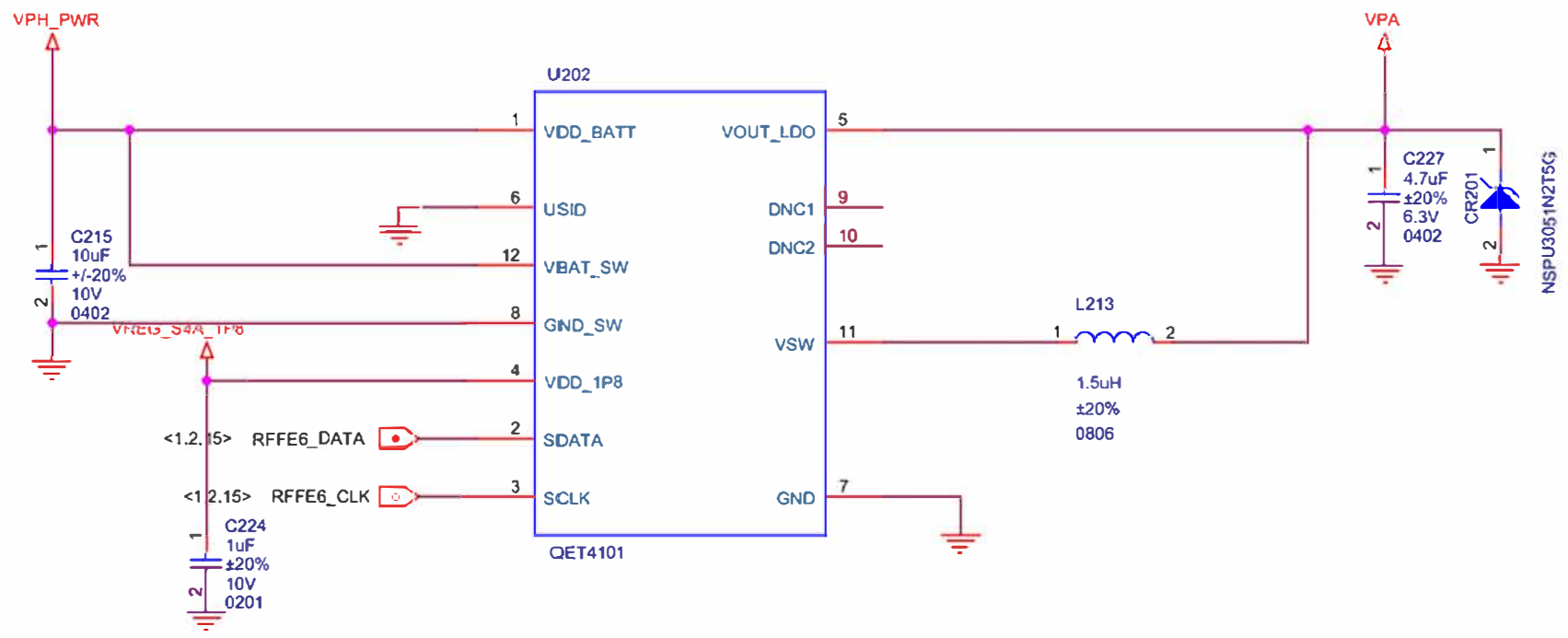

Title		
E10		
Size	Document Number	Rev
A4	QET4101	P0
Date:	Friday, May 11, 2018	Sheet 5 of 41

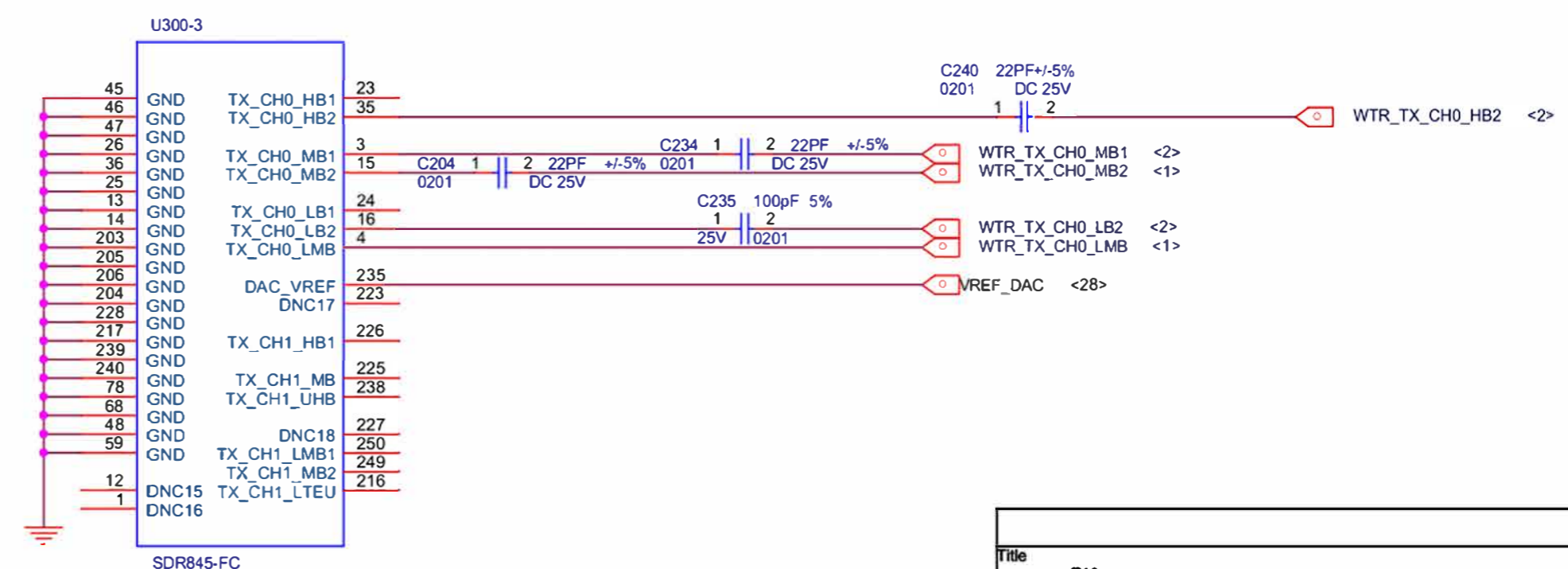
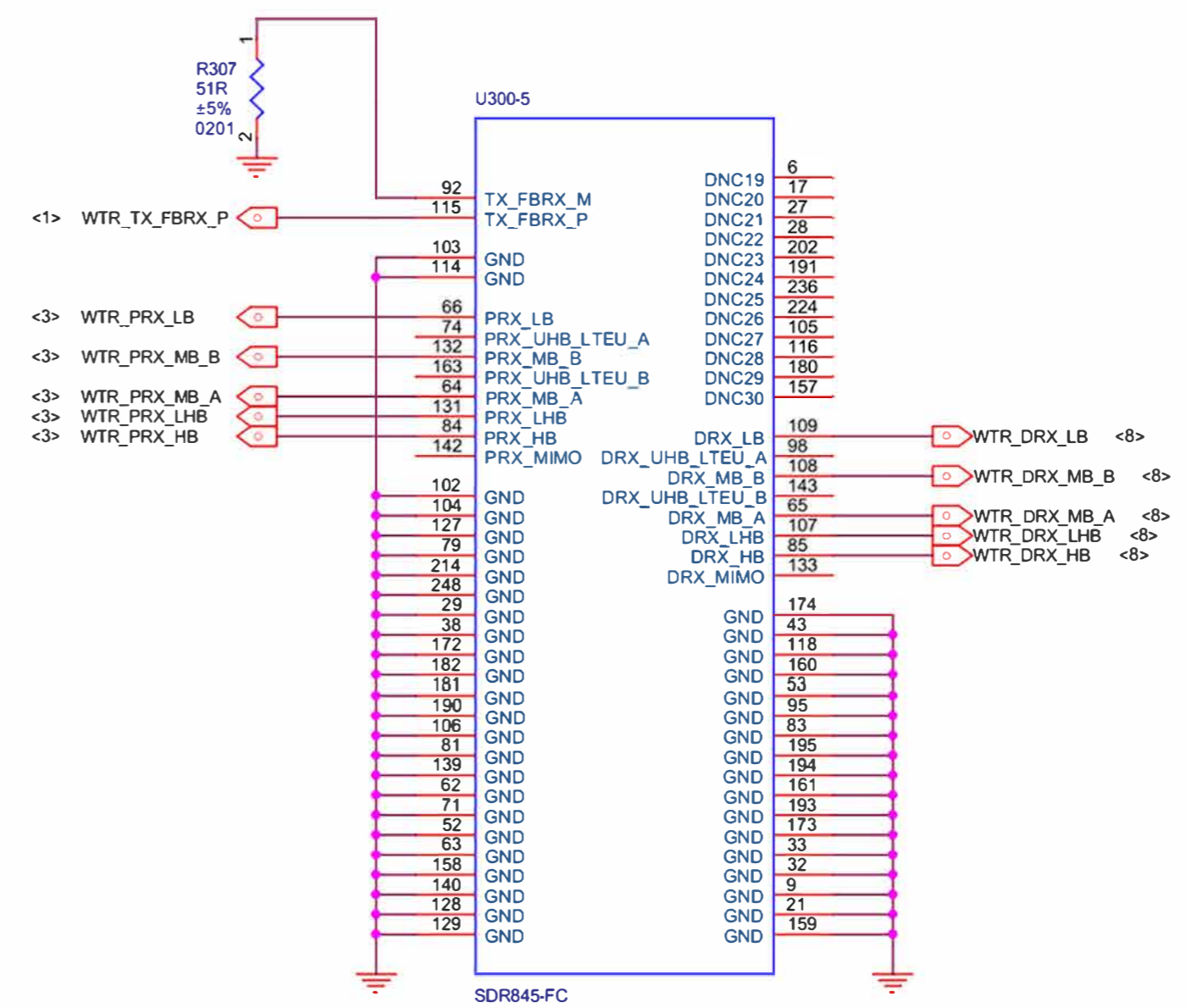
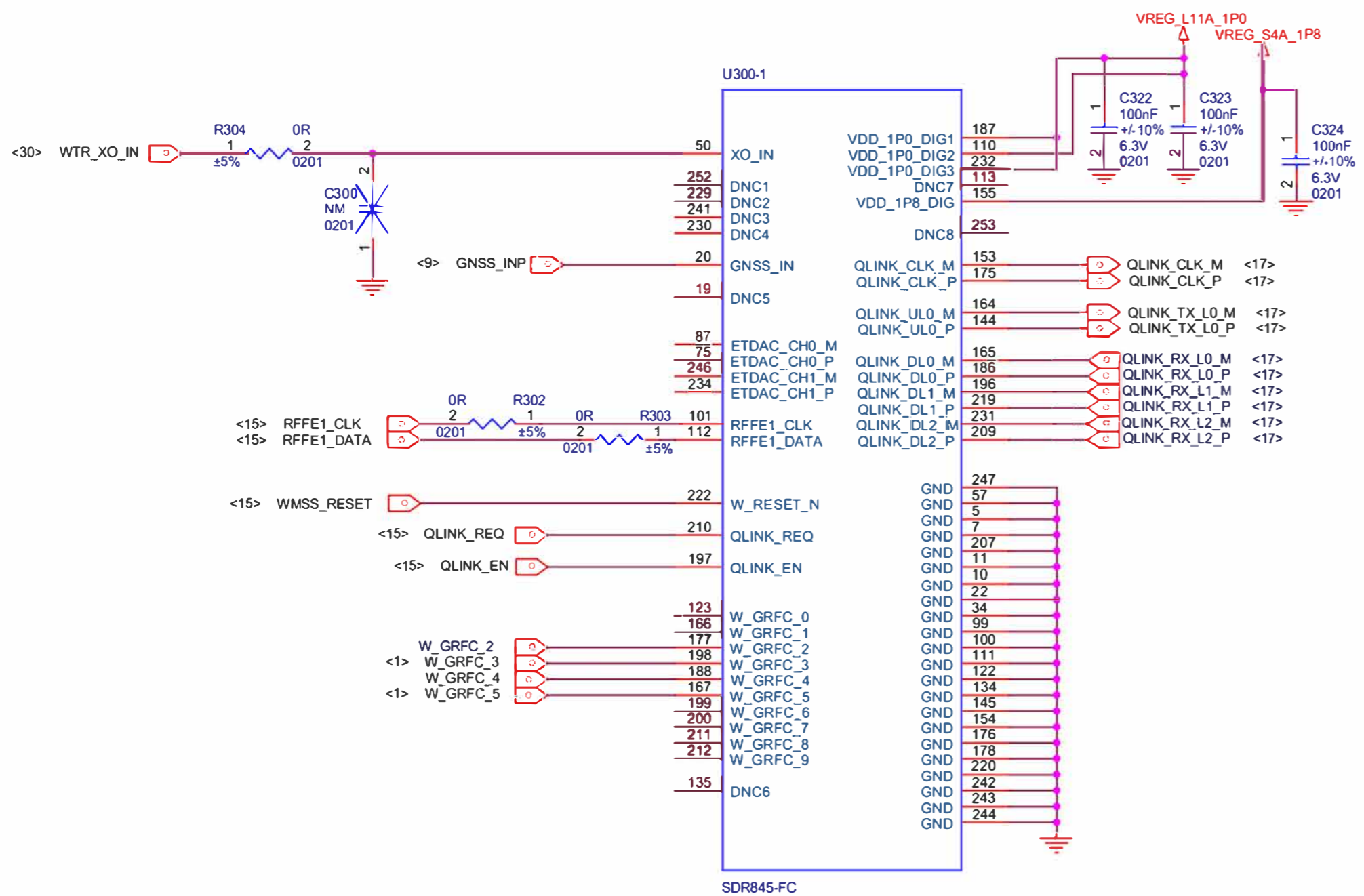

Title		
E10		
Size	Document Number	Rev
A3	WTR5975 MSS	P0

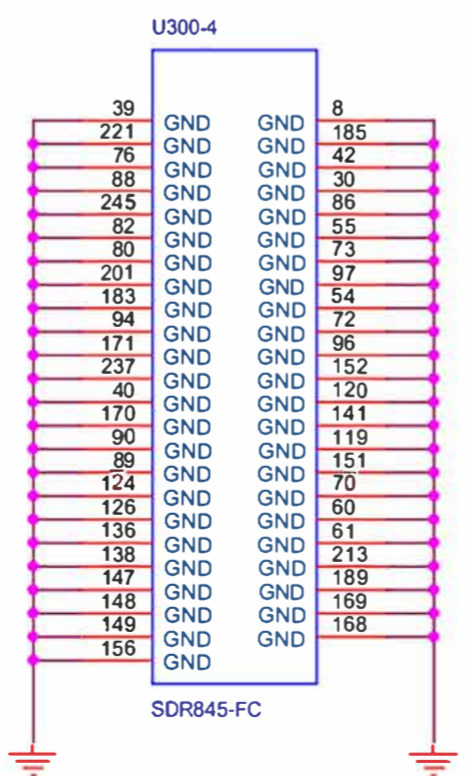
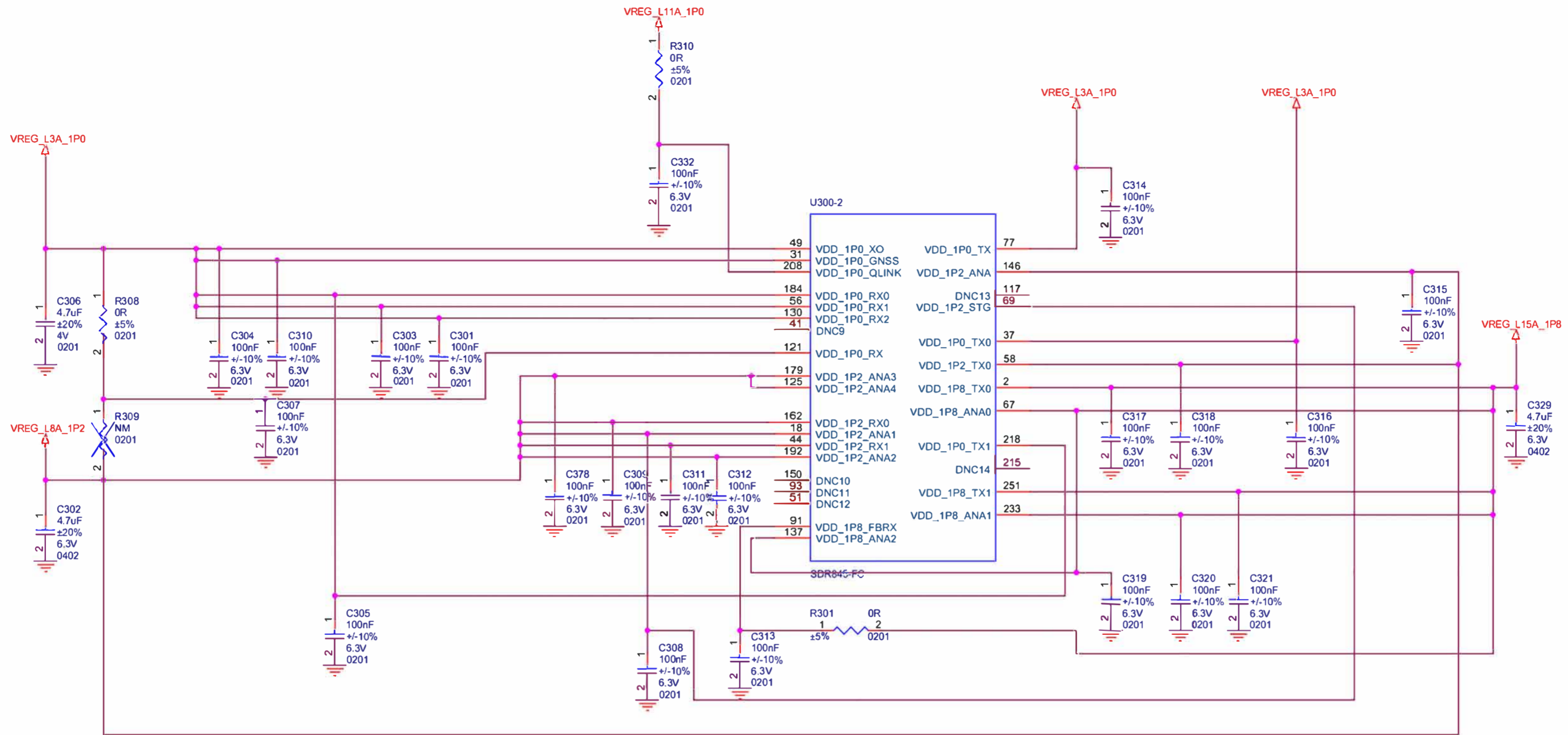

Title		
E10		
Size	Document Number	Rev
A3	WTR5975 POWER	P0
Date:	Friday, May 11, 2018	Sheet 7 of 41

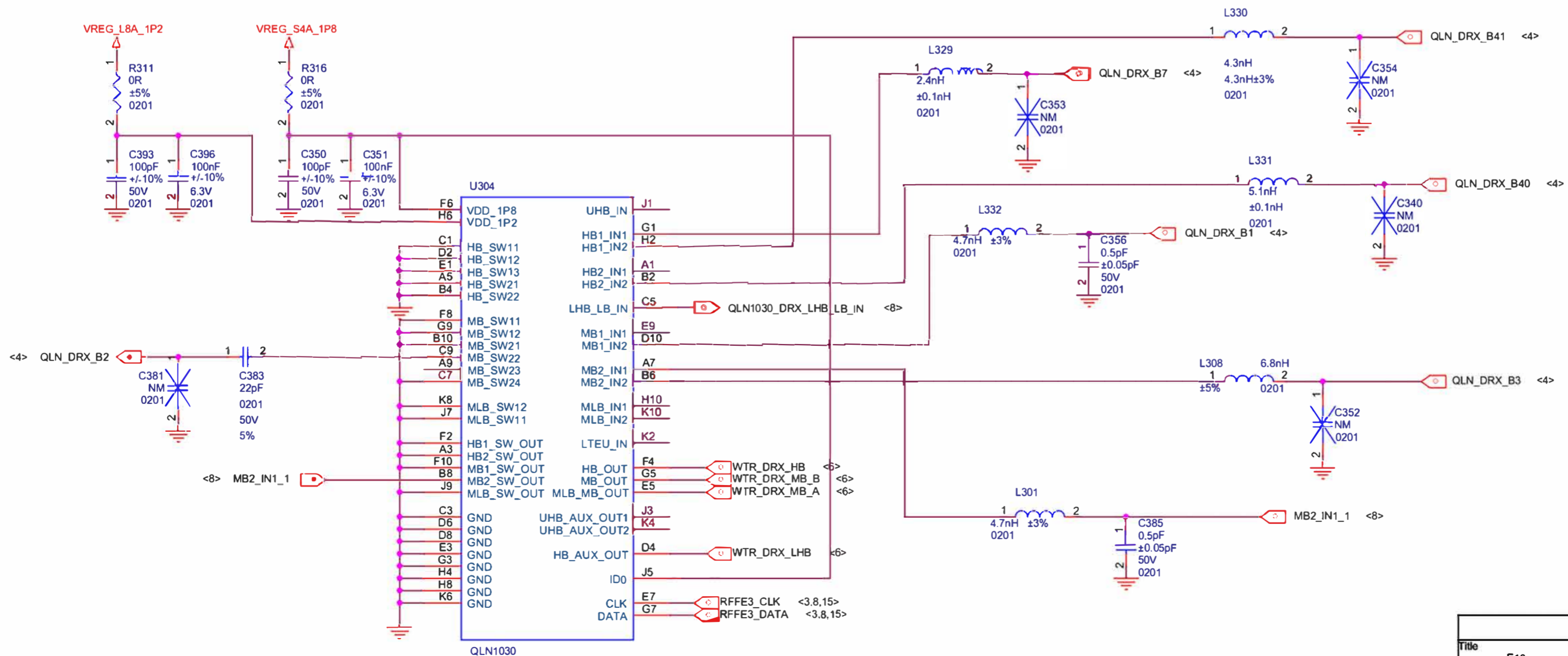
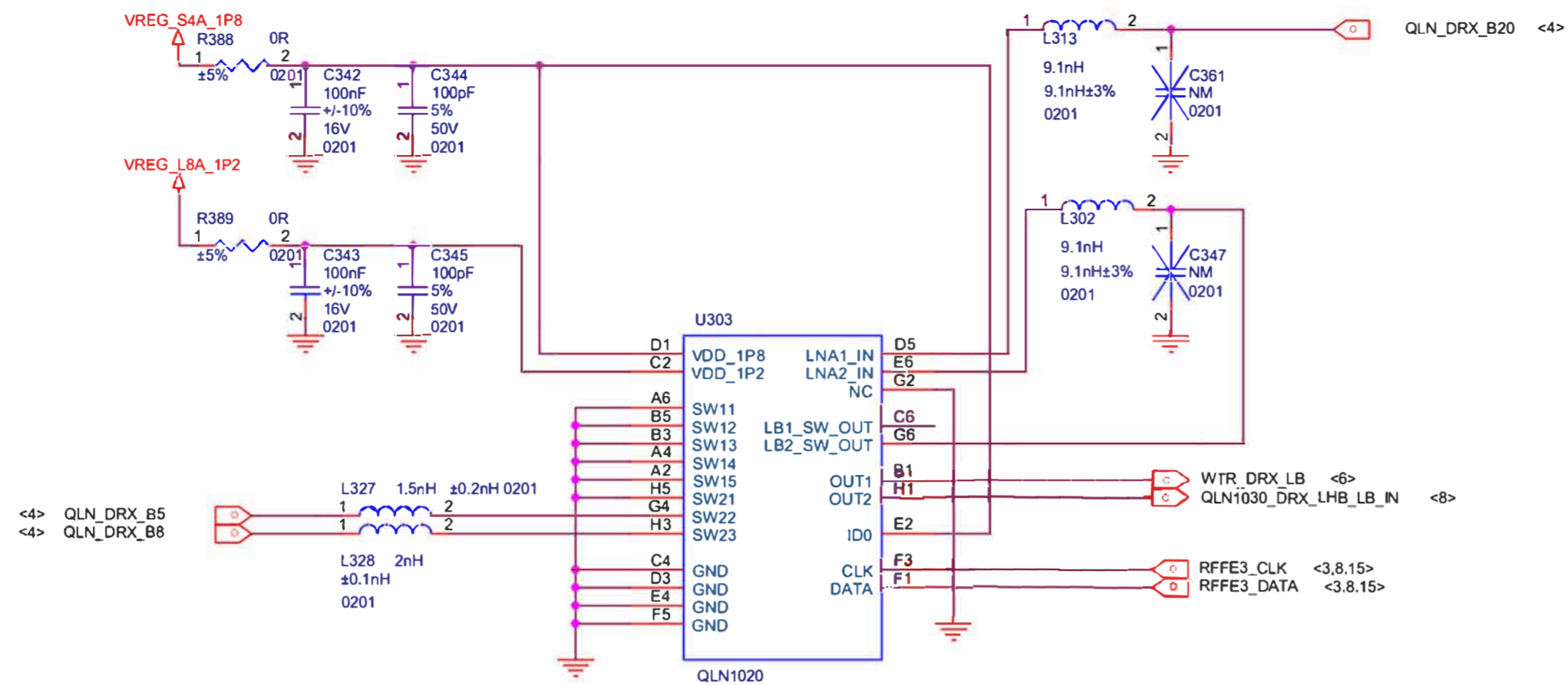

Title		
E10		
Size	Document Number	Rev
A3	QLN DRX	P0
Date:	Friday, May 11, 2018	Sheet 8 of 41



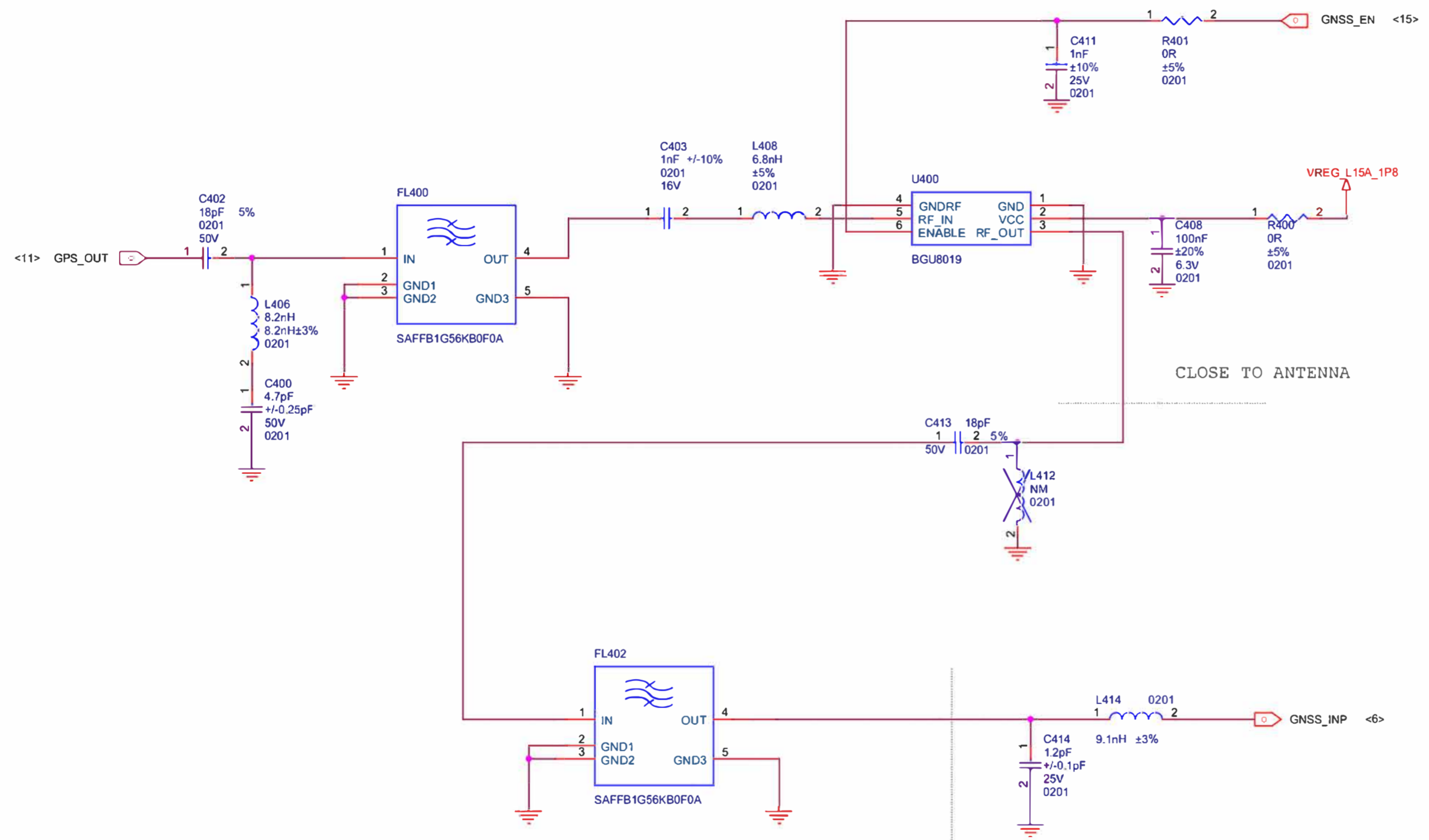

CLOSE TO ANTENNA

Title		
E10		
Size	Document Number	Rev
A3	GPS	P0
Date:	Friday, May 11, 2018	Sheet 9 of 40

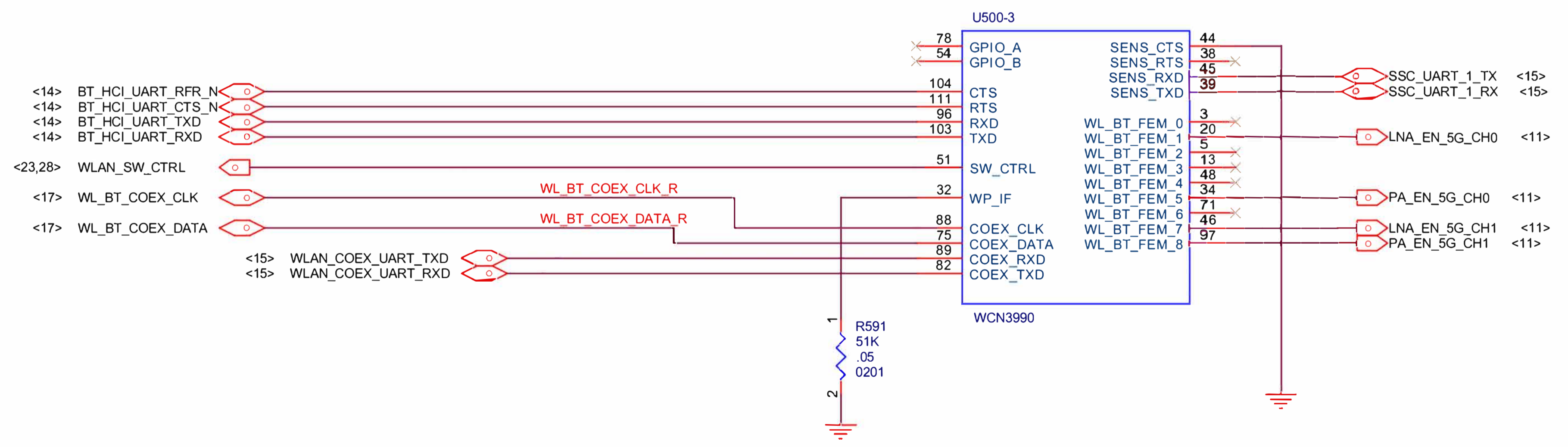
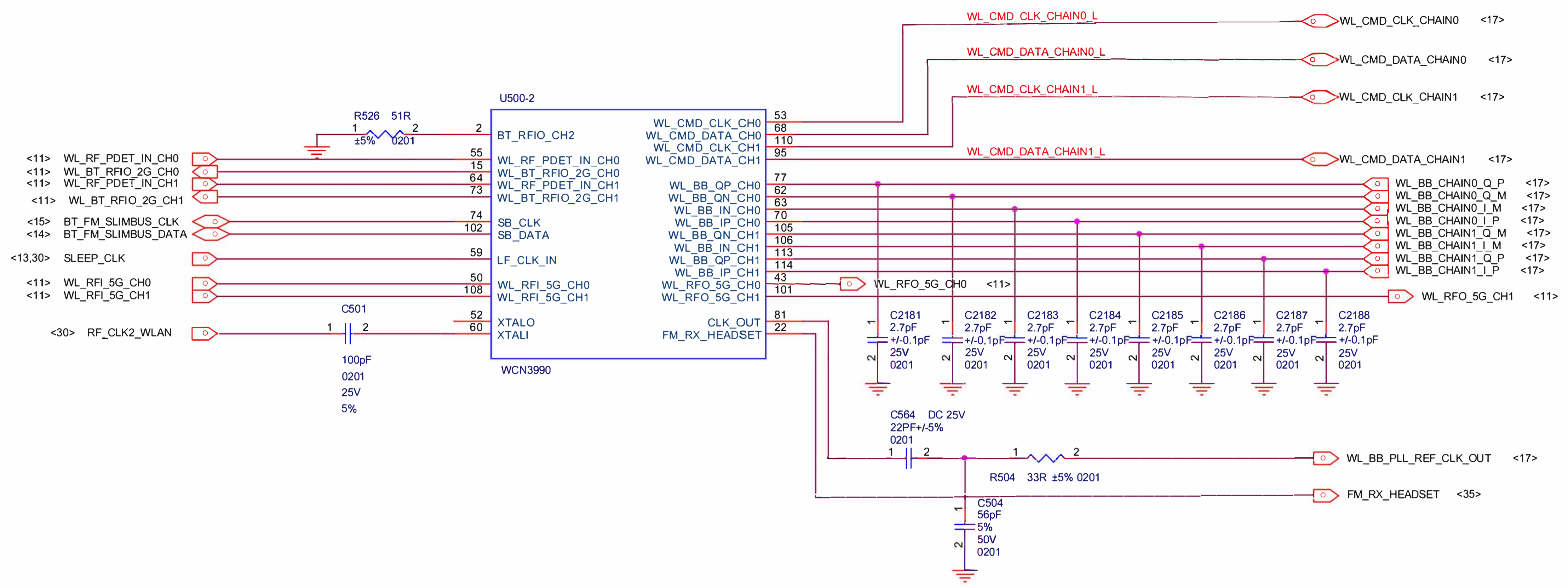

Title			E10		
Size	Document Number				Rev
A3	WIFI INTERFACE				P0
Date:	Friday, May 11, 2018	Sheet	10	of	40

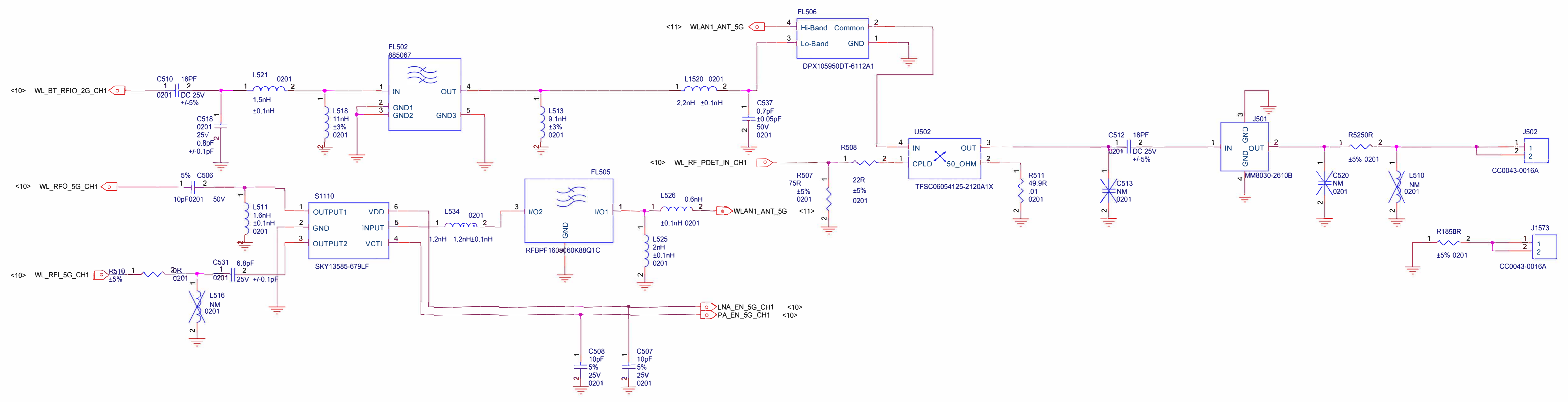
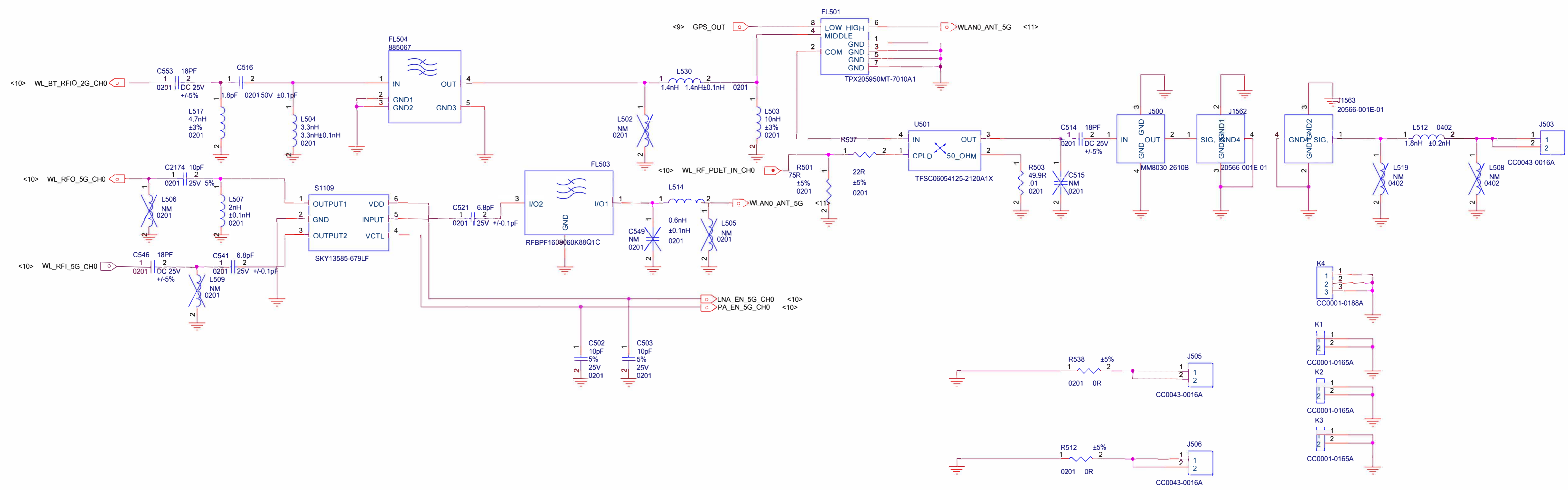

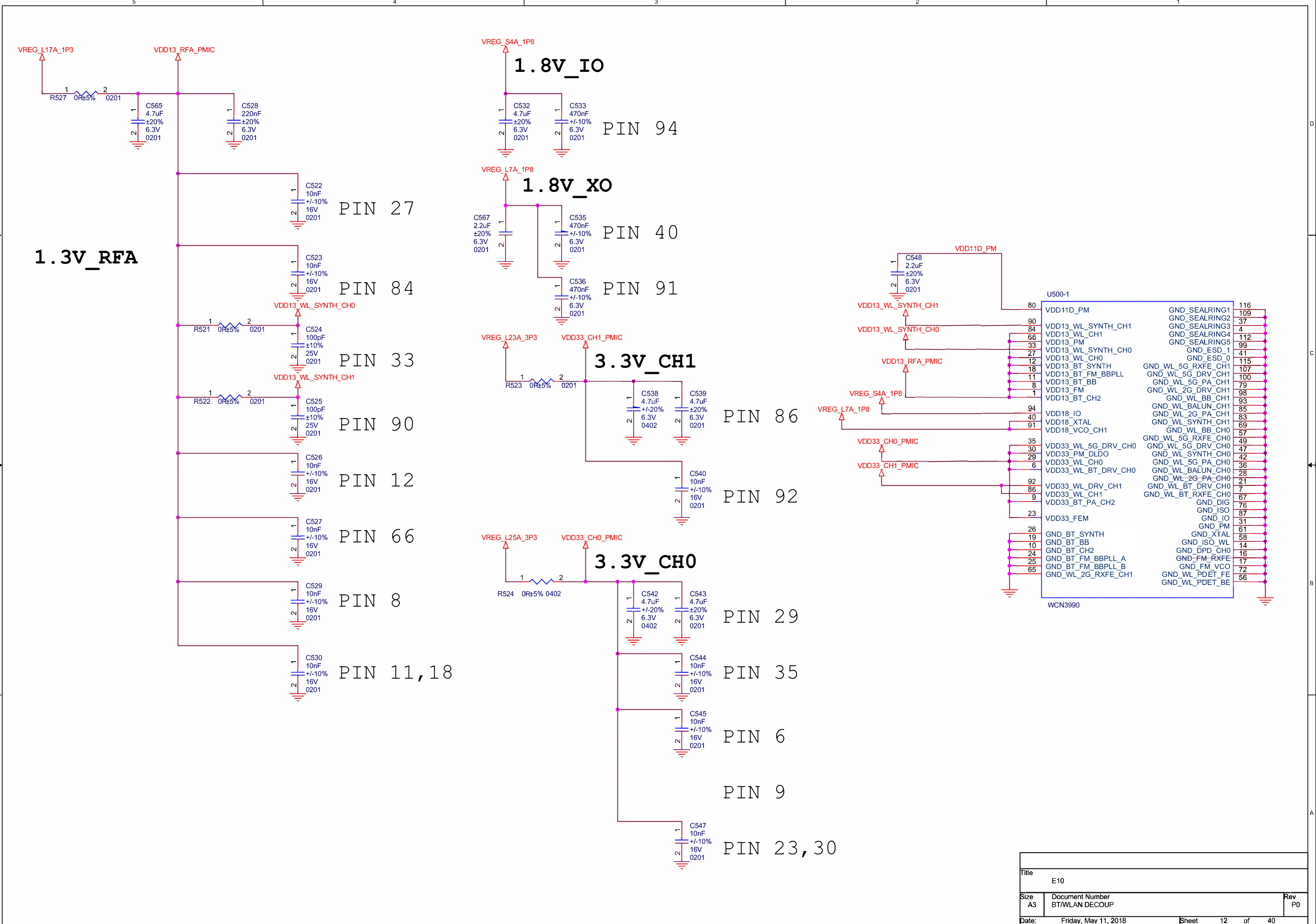

**1.3V\_RFA**

**1.8V\_IO**

**1.8V\_XO**

**3.3V\_CH1**

**3.3V\_CH0**

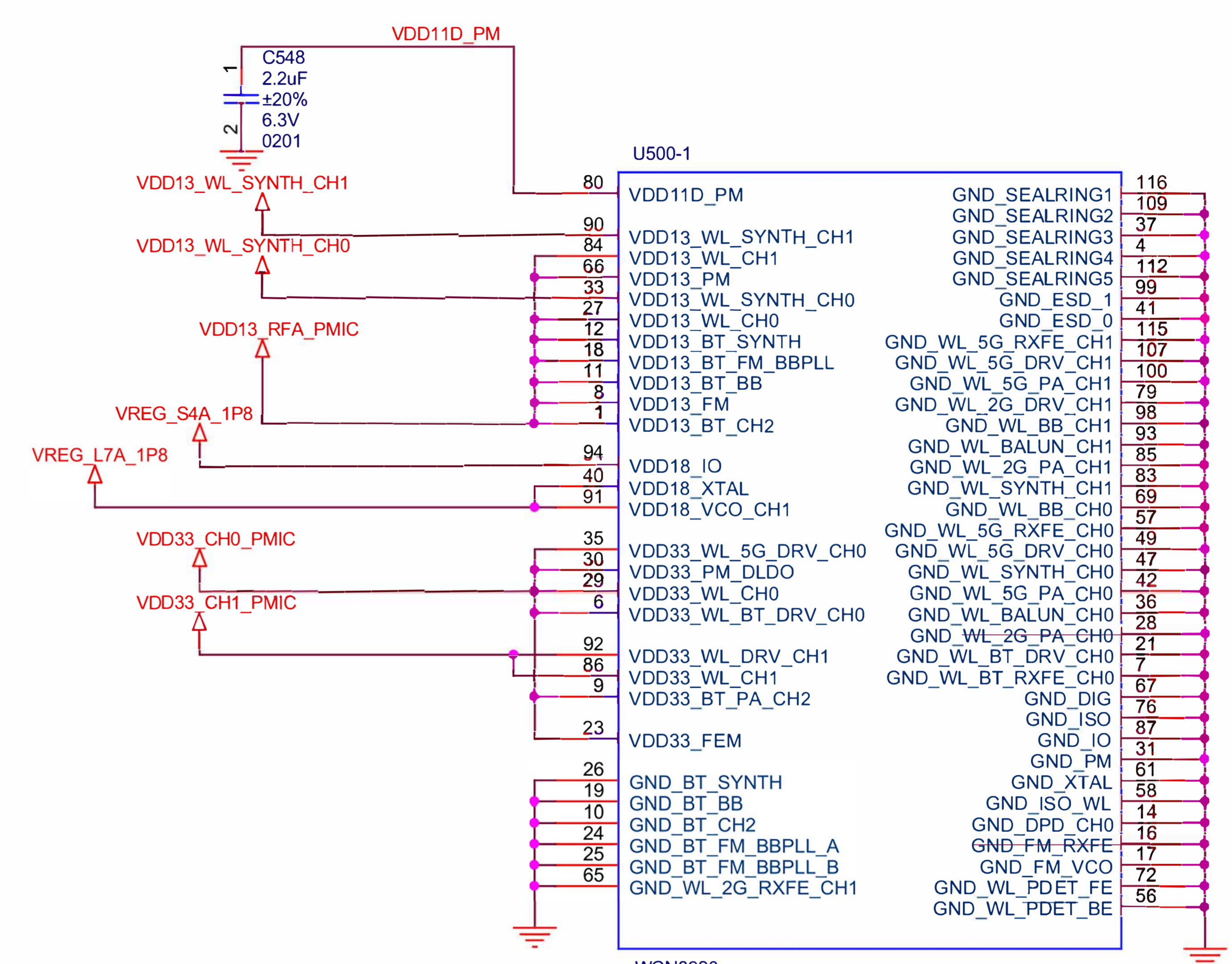
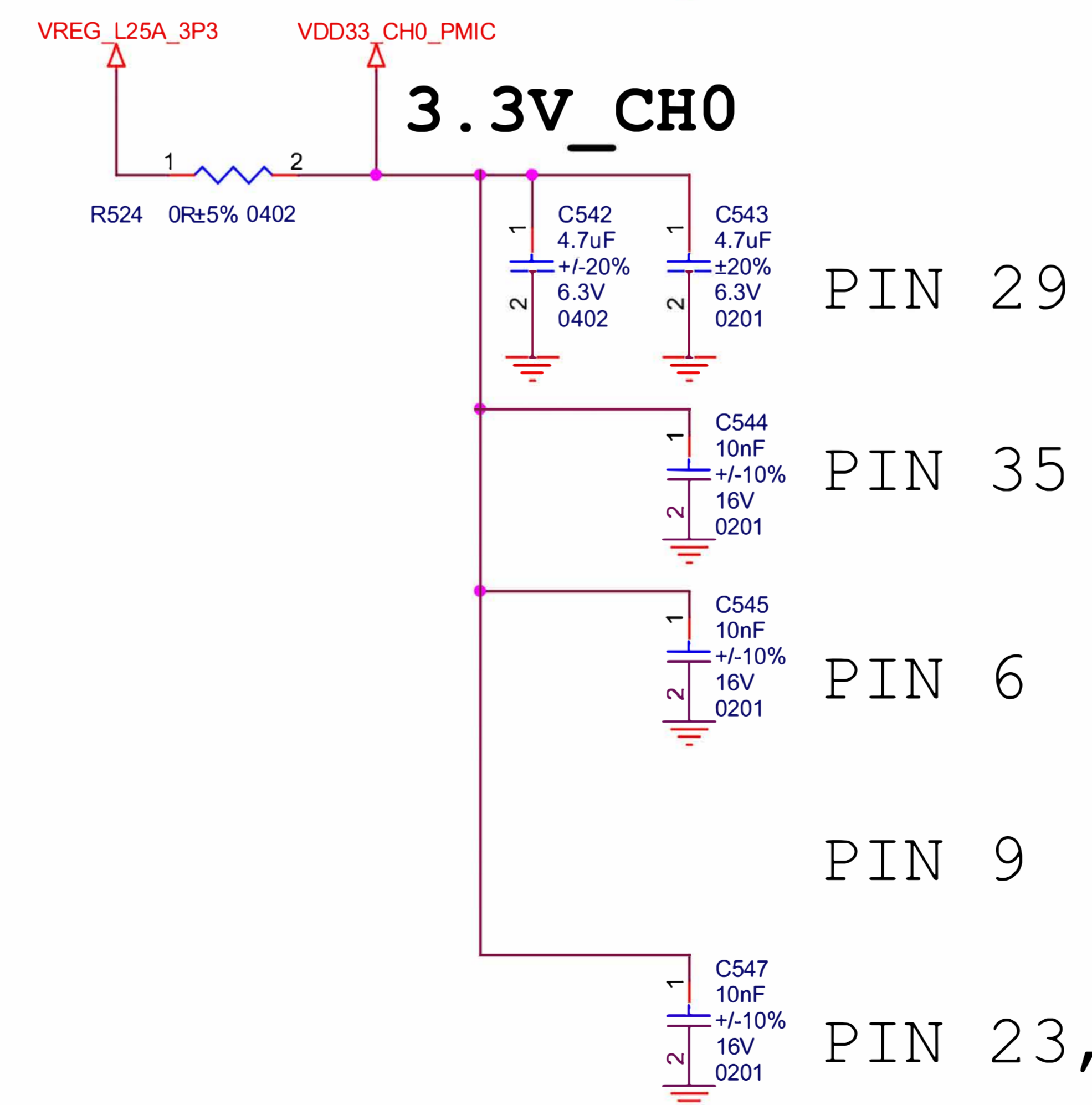
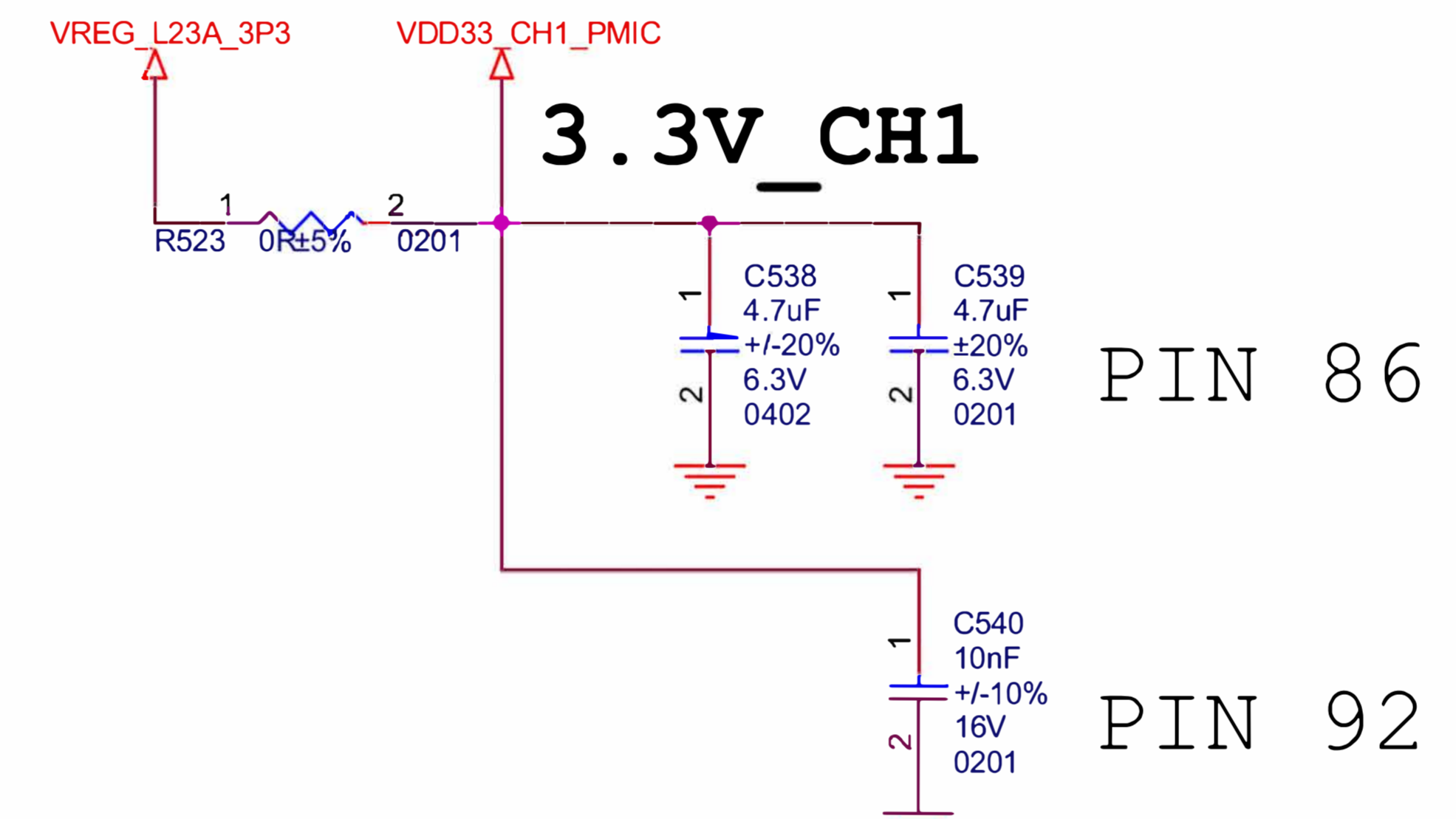
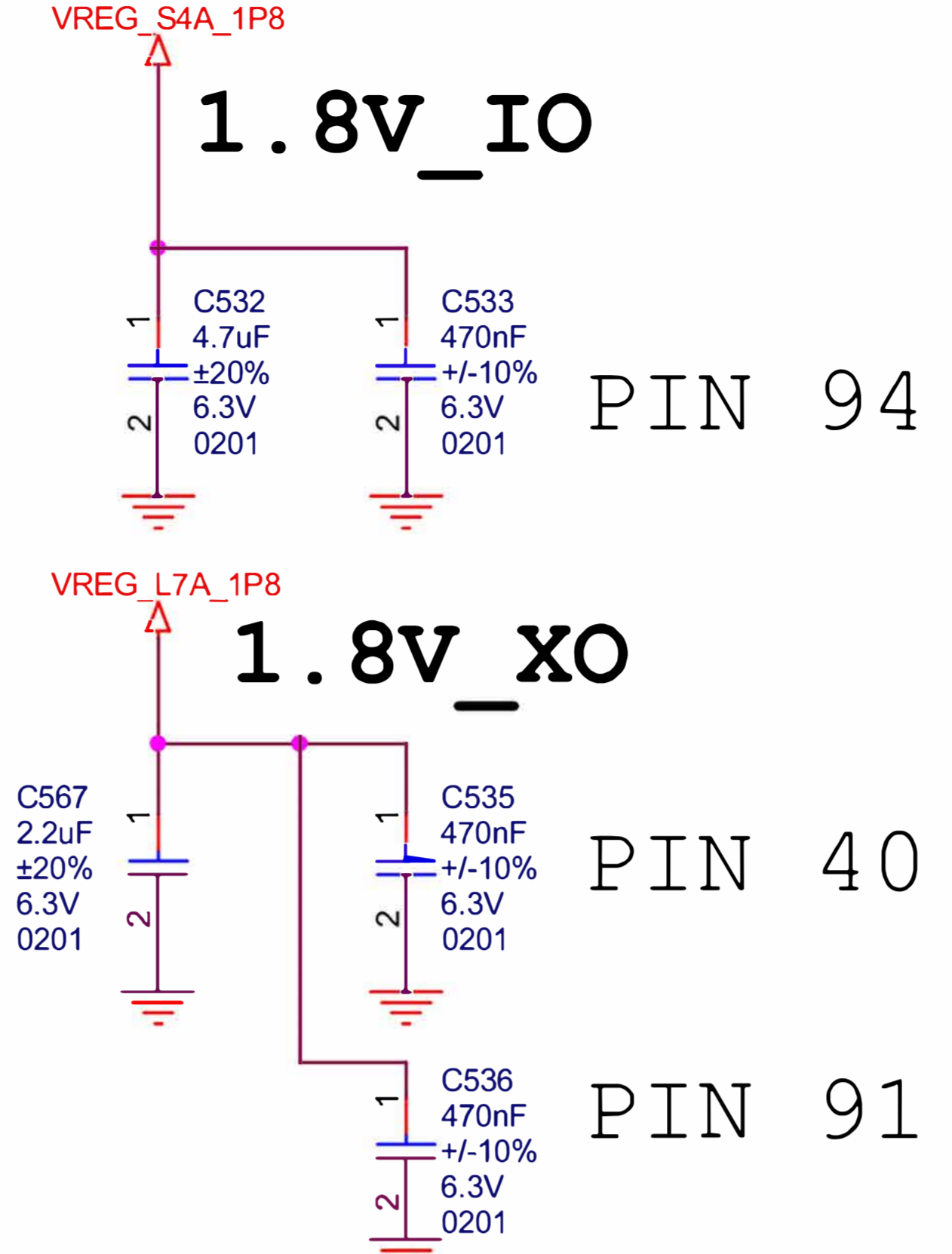
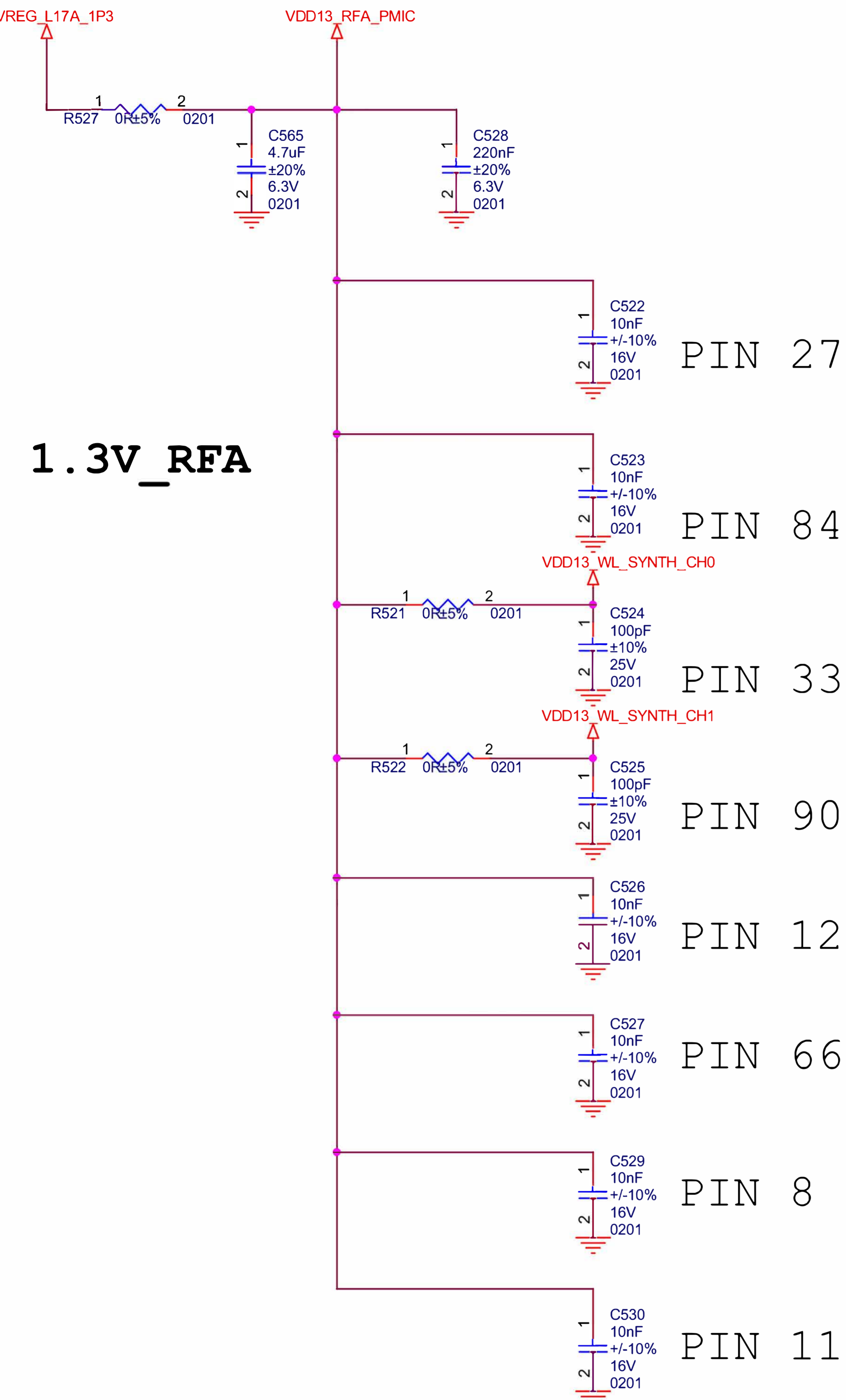

116	GND_SEALRING1	116
109	GND_SEALRING2	109
4	GND_SEALRING3	4
112	GND_SEALRING4	112
99	GND_SEALRING5	99
41	GND_ESD_1	41
115	GND_ESD_0	115
107	GND_WL_5G_RXFE_CH1	107
100	GND_WL_5G_PA_CH1	100
79	GND_WL_2G_DRV_CH1	79
98	GND_WL_BB_CH1	98
93	GND_WL_BALUN_CH1	93
85	GND_WL_2G_PA_CH1	85
83	GND_WL_SYNTH_CH1	83
69	GND_WL_BB_CH0	69
57	GND_WL_5G_RXFE_CH0	57
49	GND_WL_5G_DRV_CH0	49
47	GND_WL_SYNTH_CH0	47
42	GND_WL_5G_PA_CH0	42
36	GND_WL_BALUN_CH0	36
28	GND_WL_2G_PA_CH0	28
21	GND_WL_BT_DRV_CH0	21
7	GND_WL_BT_RXFE_CH0	7
67	GND_DIG	67
76	GND_ISO	76
87	GND_IO	87
31	GND_PM	31
61	GND_XTAL	61
58	GND_ISO_WL	58
14	GND_DPD_CH0	14
16	GND_FM_RXFE	16
17	GND_FM_VCO	17
72	GND_WL_PDET_FE	72
56	GND_WL_PDET_BE	56

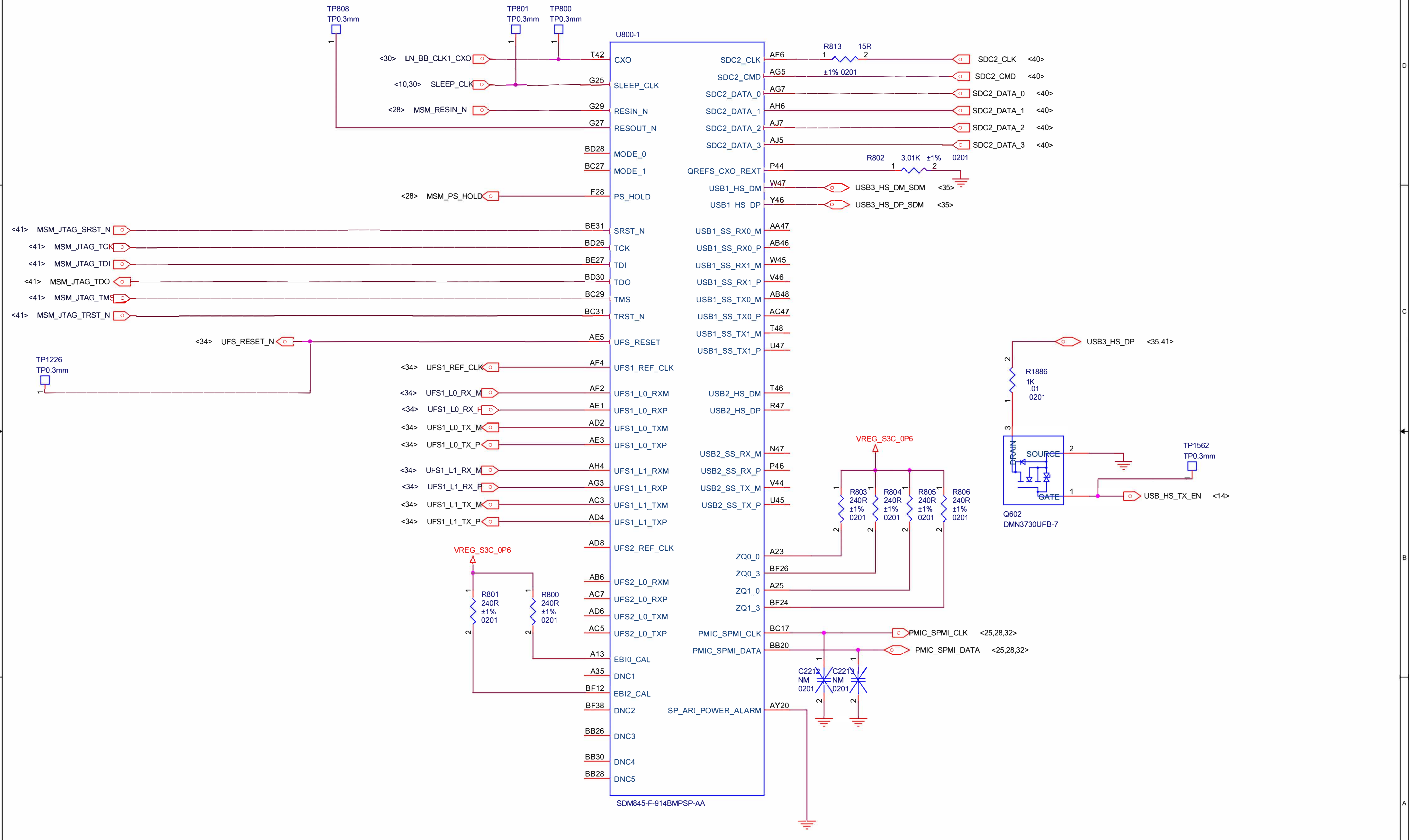

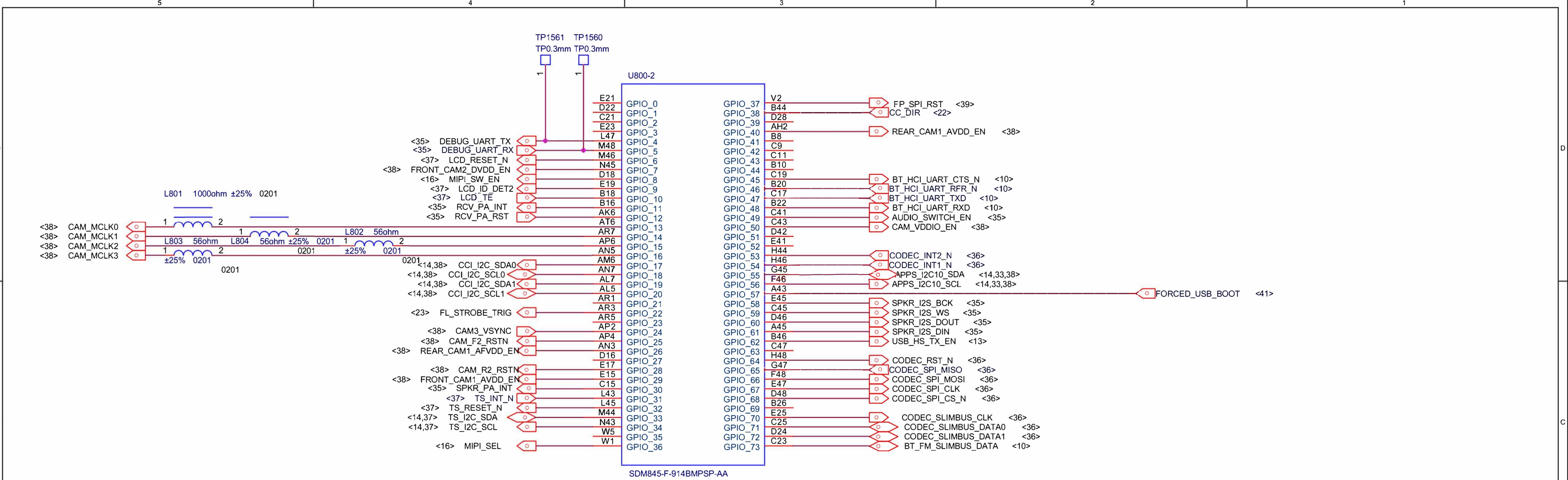

SENSOR

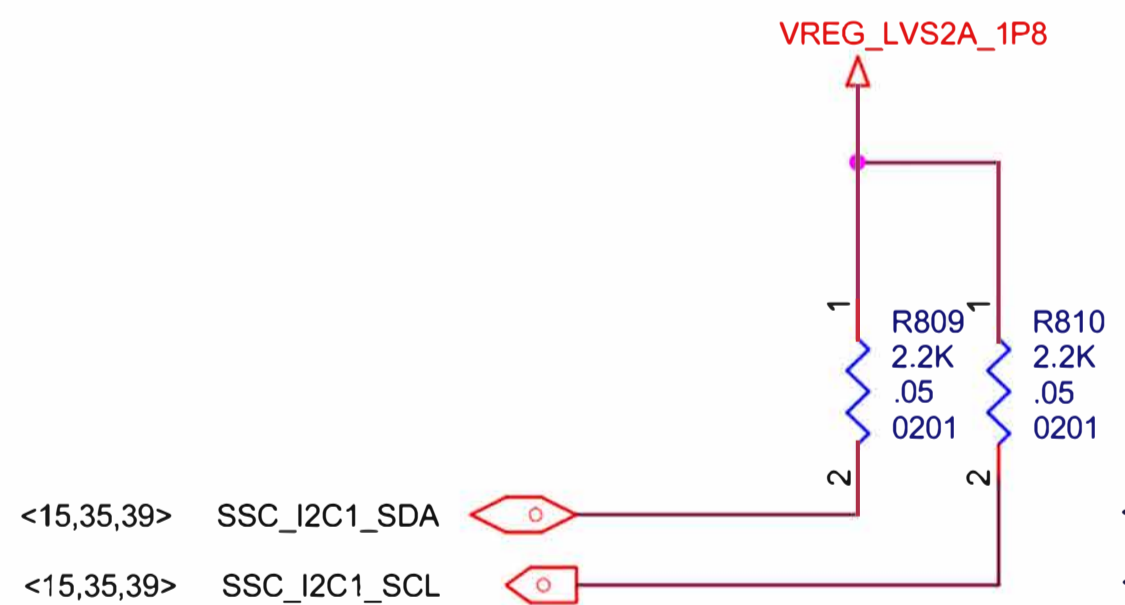

APPS

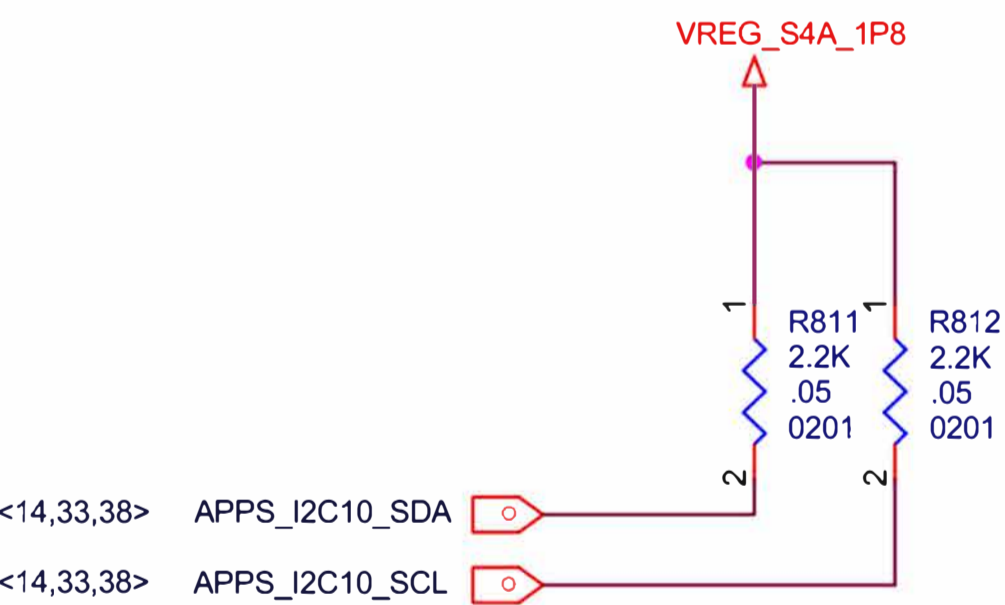

REAR CAMERA

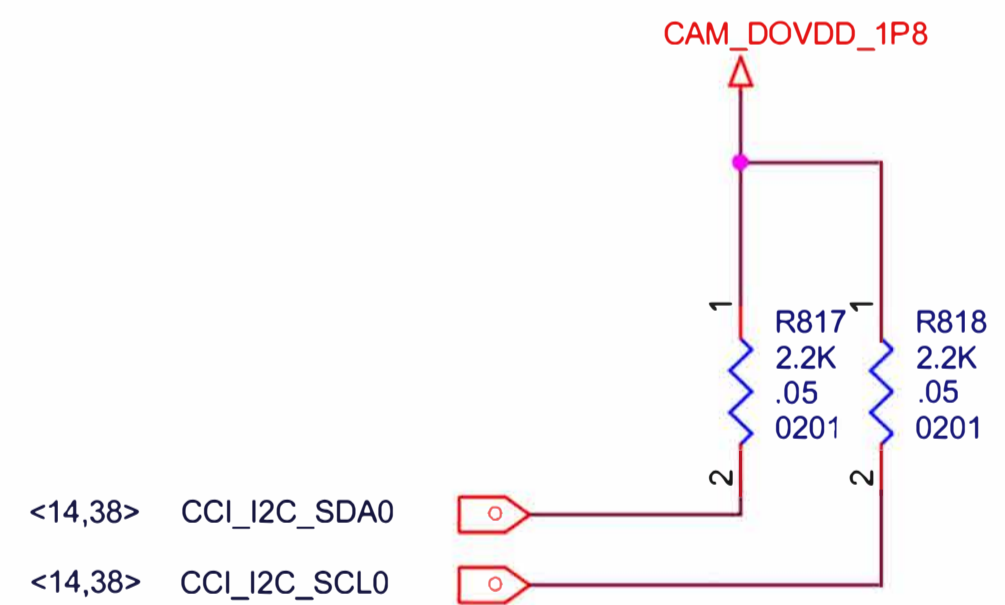

TP

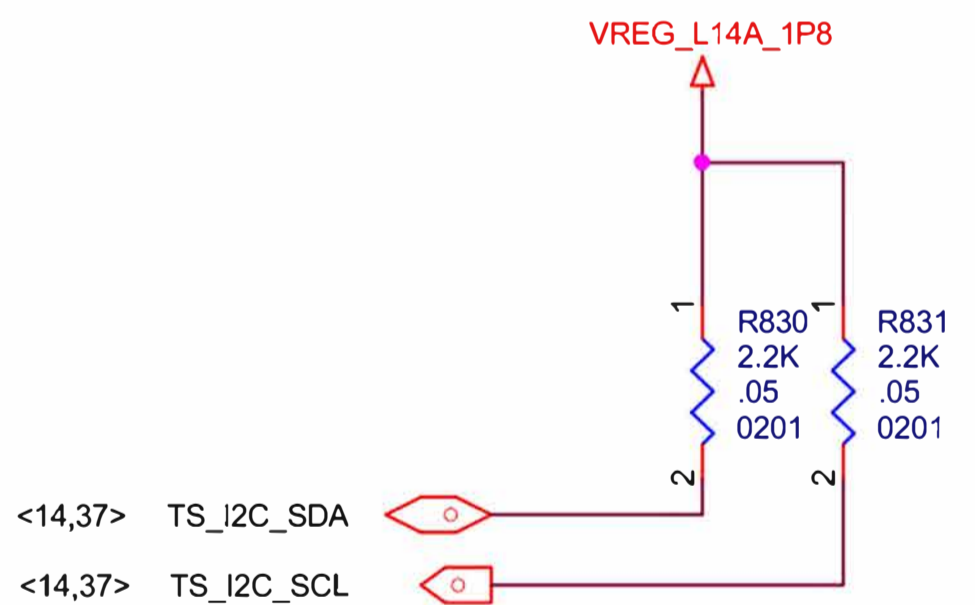

FRONT CAMERA

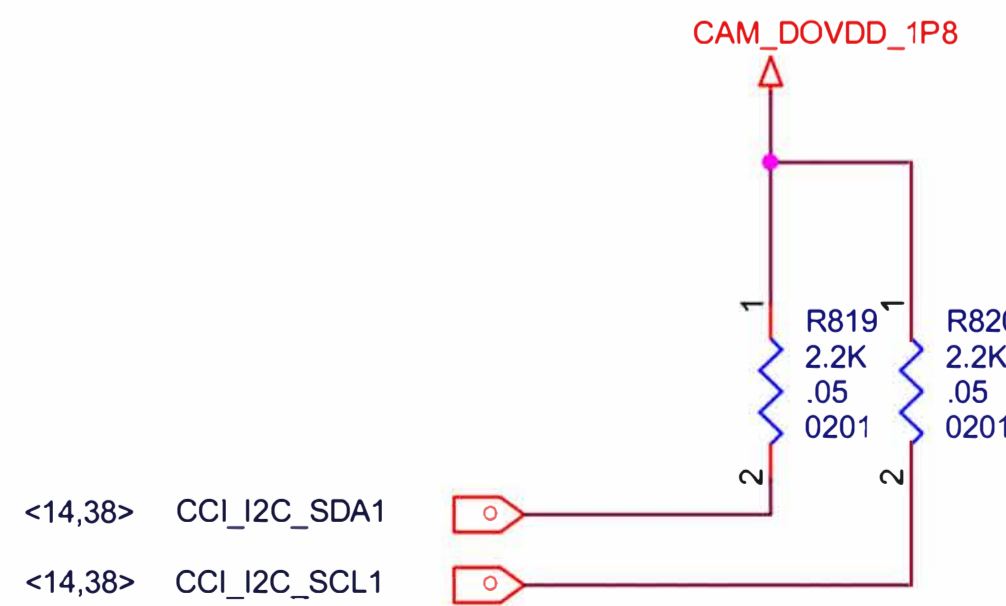

AUDIO&WPC

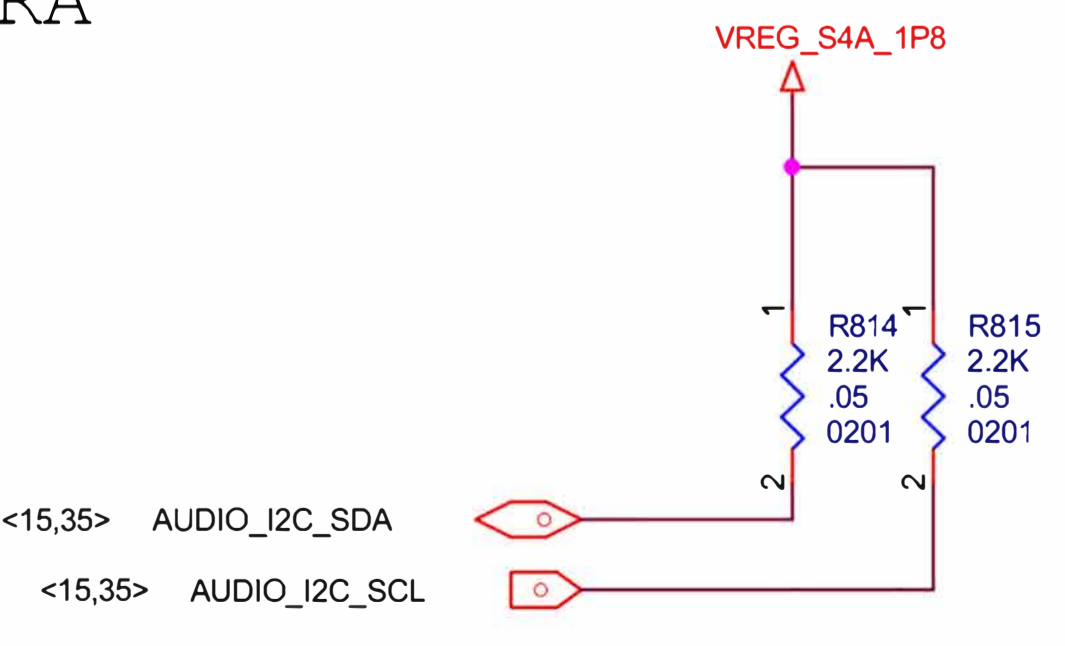

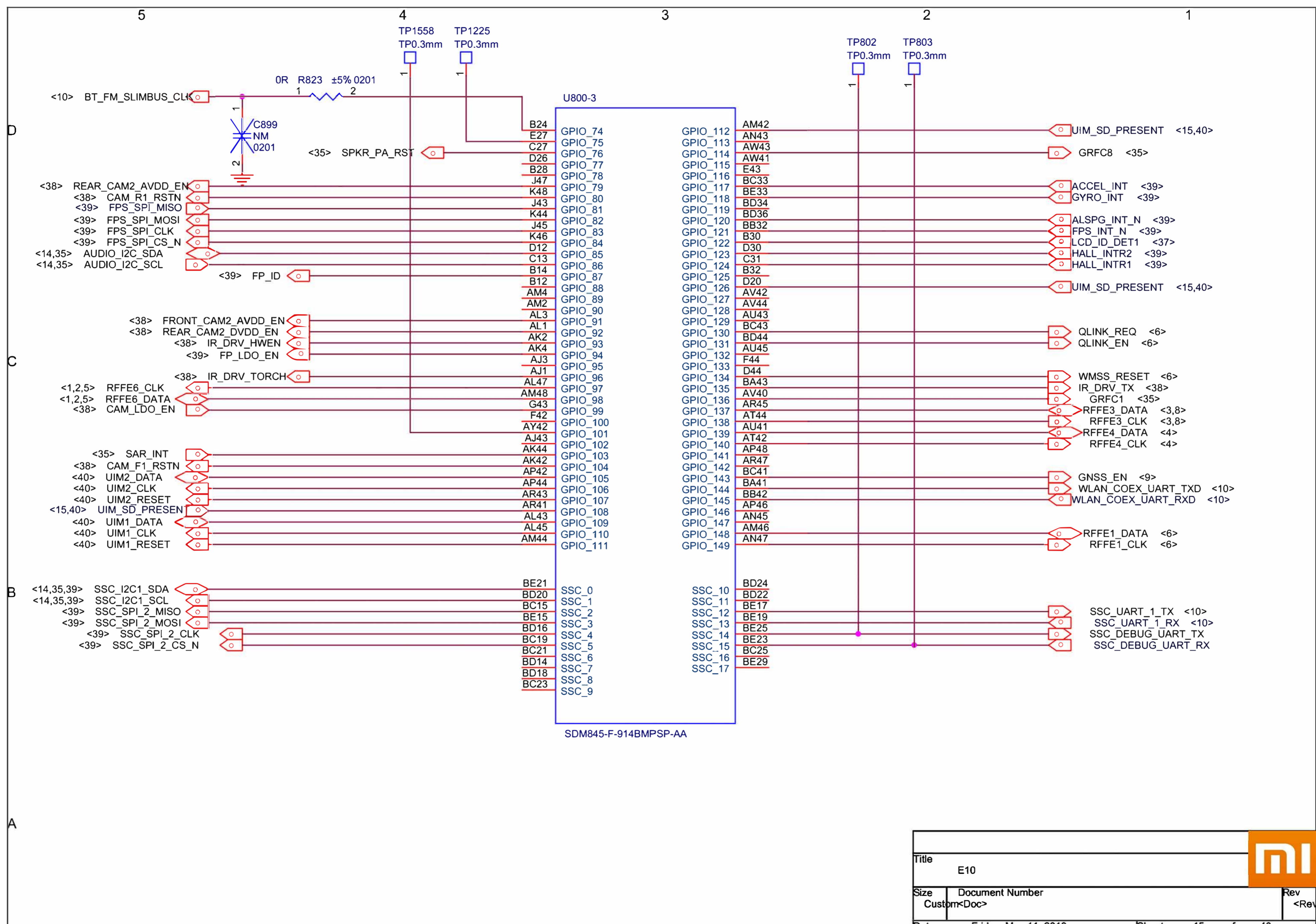

REAR CAMERA 12M

REAR CAMERA 5M

FRONT CAMERA 20M

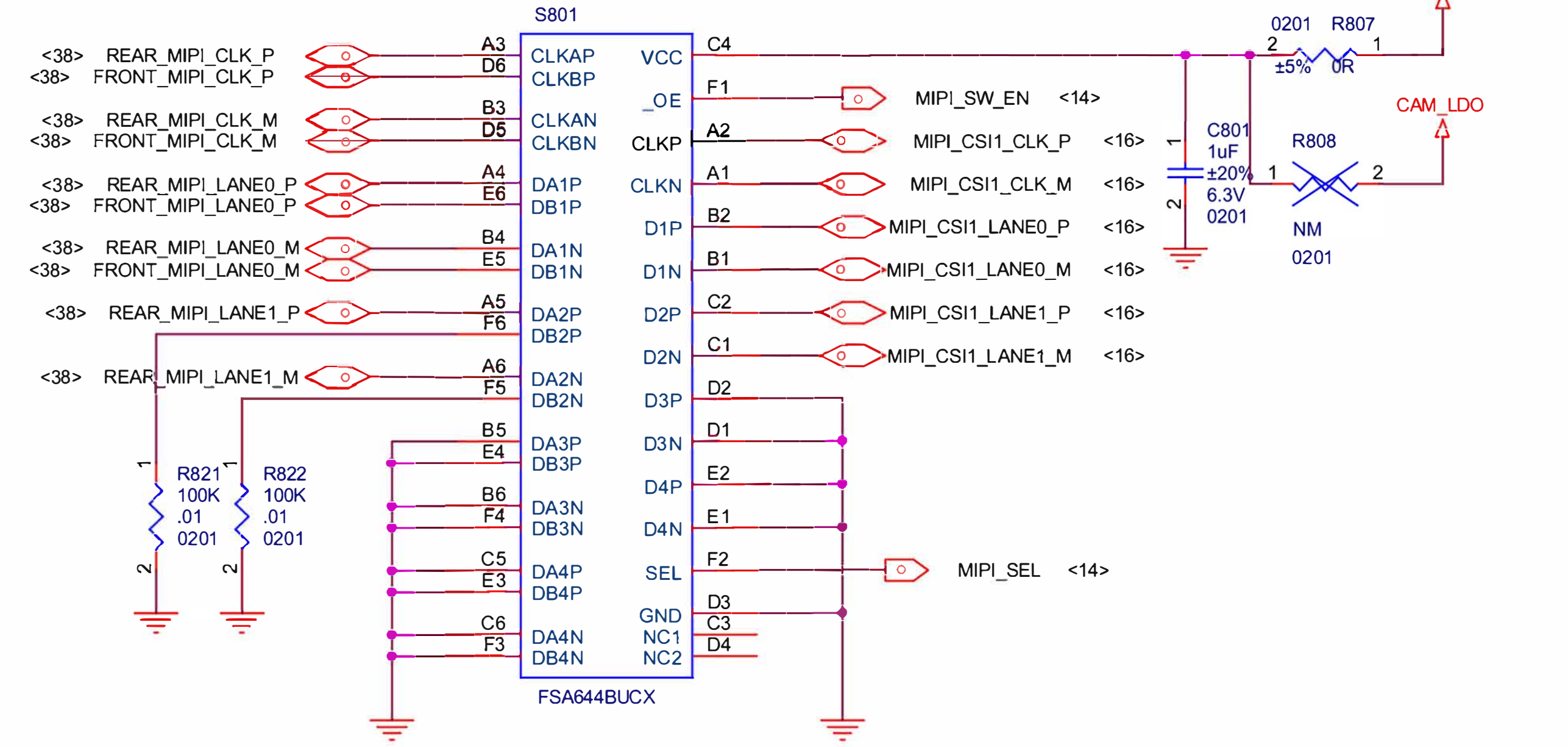
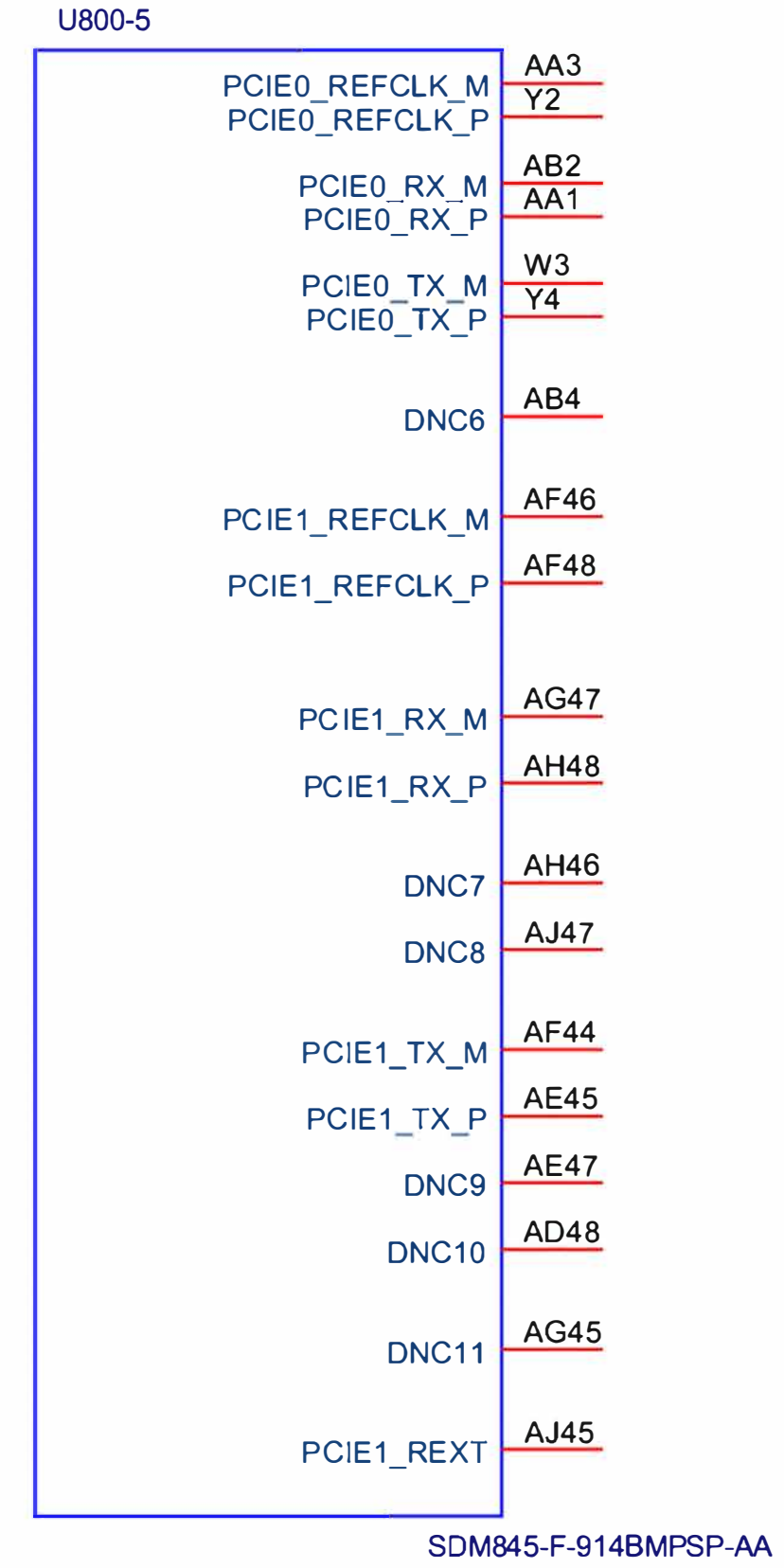
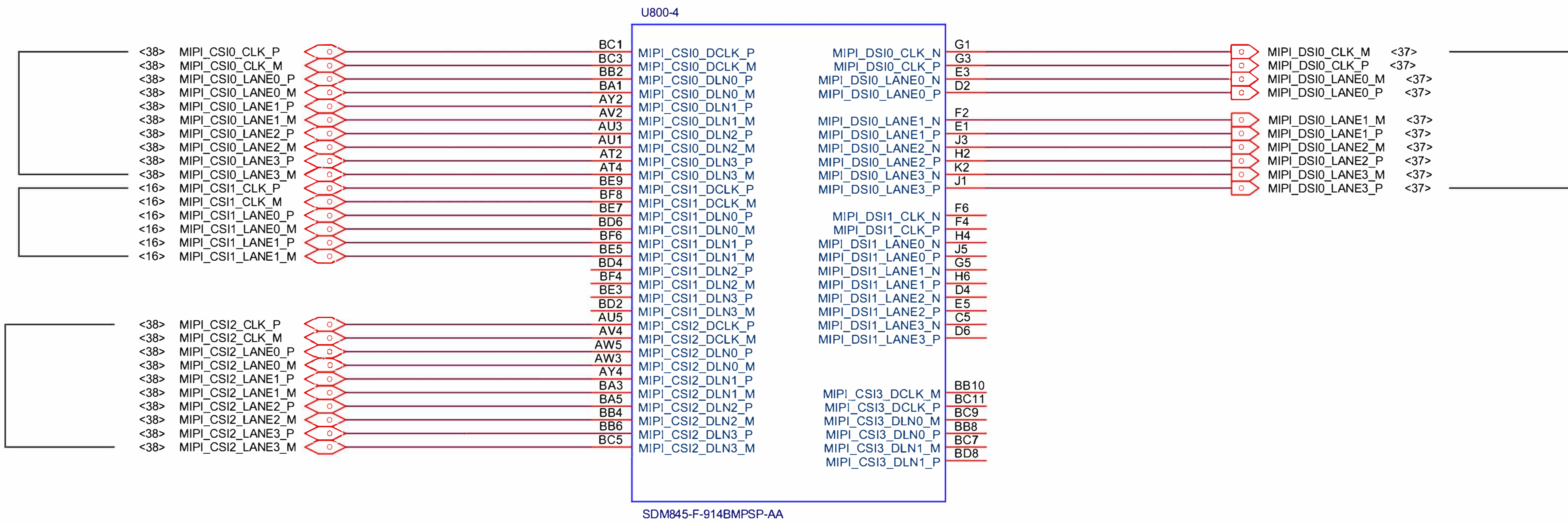



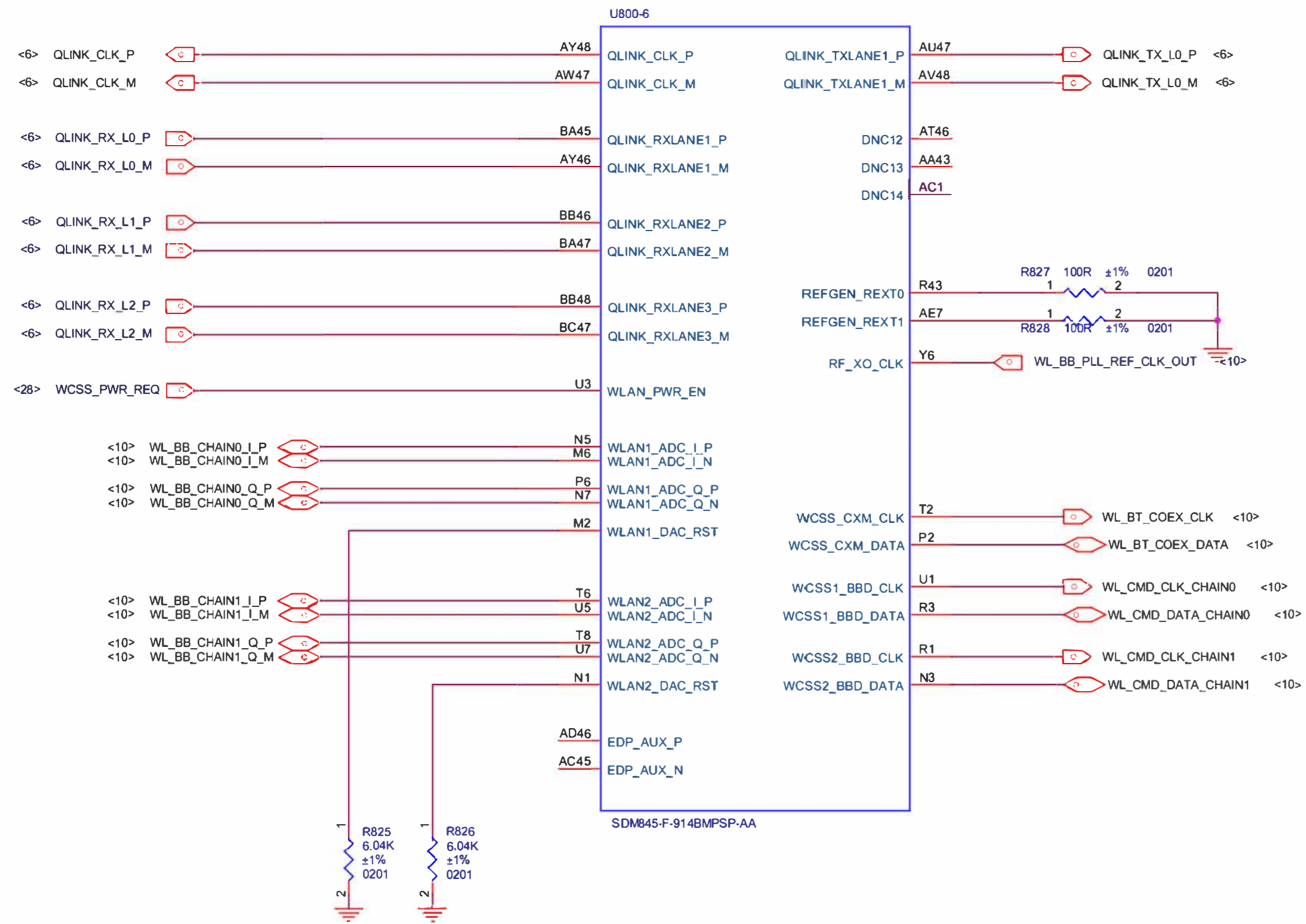

Title		
E10		
Size	Document Number	Rev
A3	MSM8998 RF INTF	P0
Date:	Friday, May 11, 2018	Sheet 17 of 40

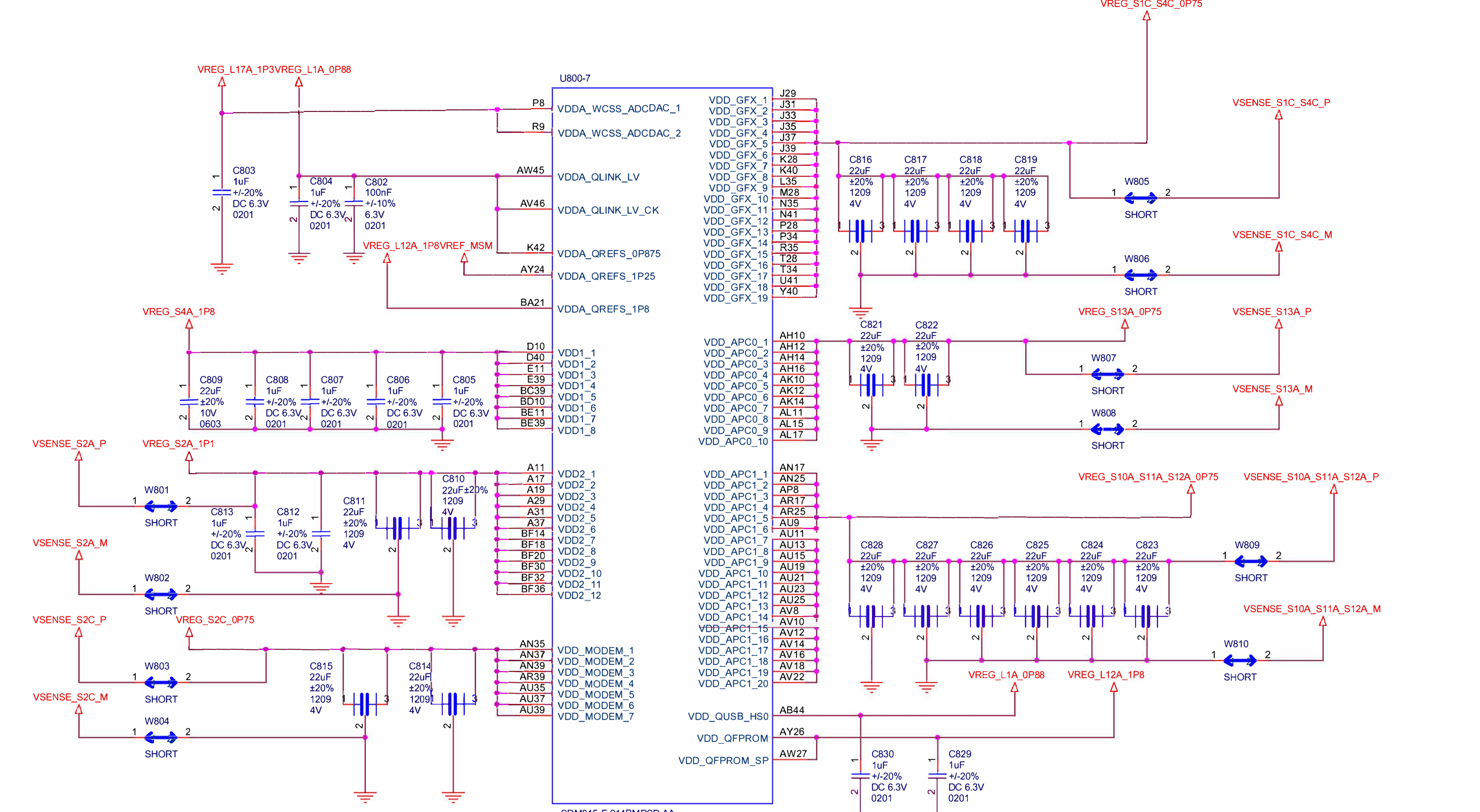

SDM845-F-914BMSP-AA

Title		
E10		
Size	Document Number	Rev
A3	MSM8998 PWR1	P0
Date:	Friday, May 11, 2018	Sheet 18 of 40

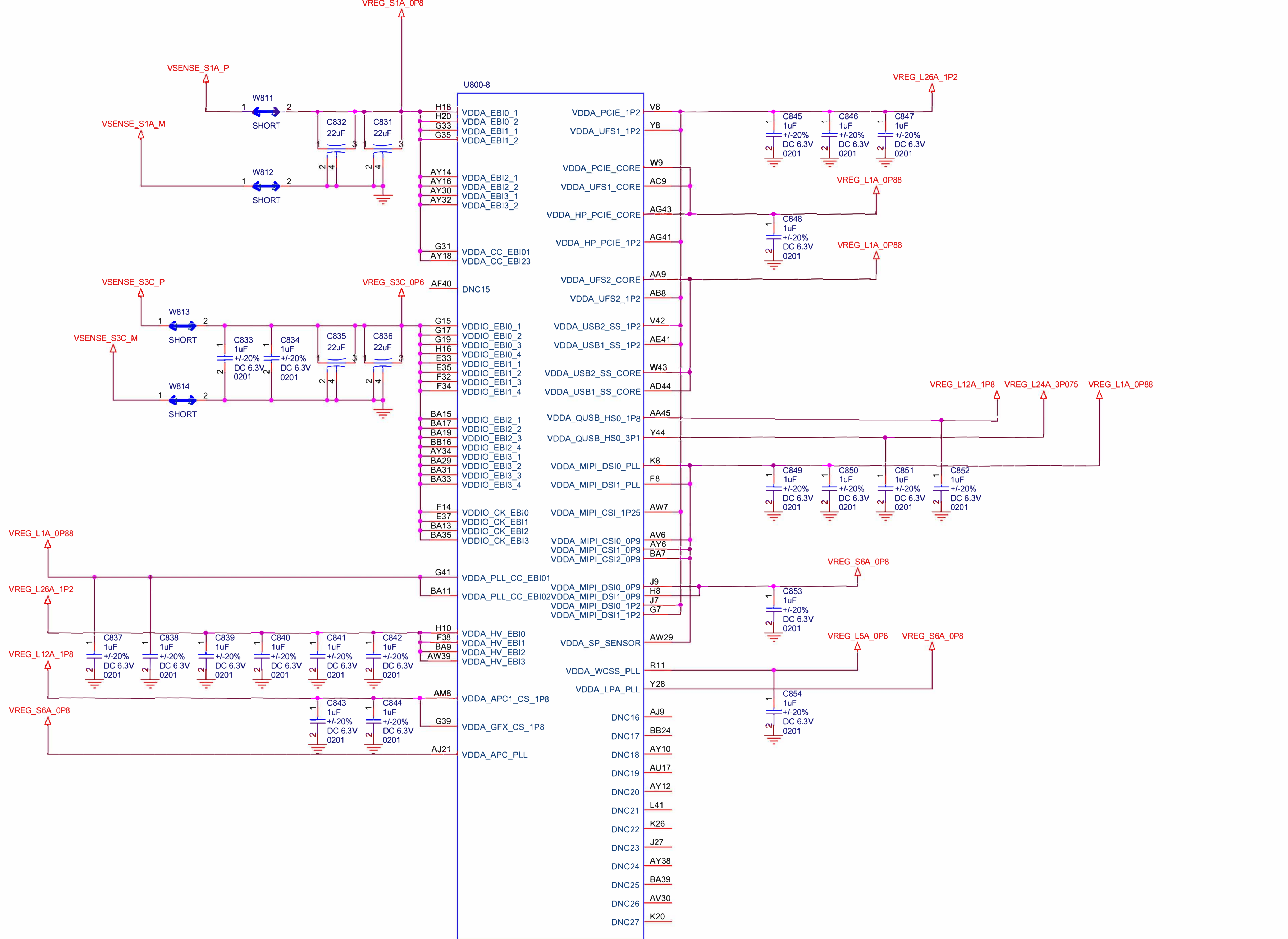

SDM845-F-914BMPSP-AA

Title		
E10		
Size	Document Number	Rev
A3	MSM8998 PWR2	P0
Date:	Friday, May 11, 2018	Sheet 19 of 40

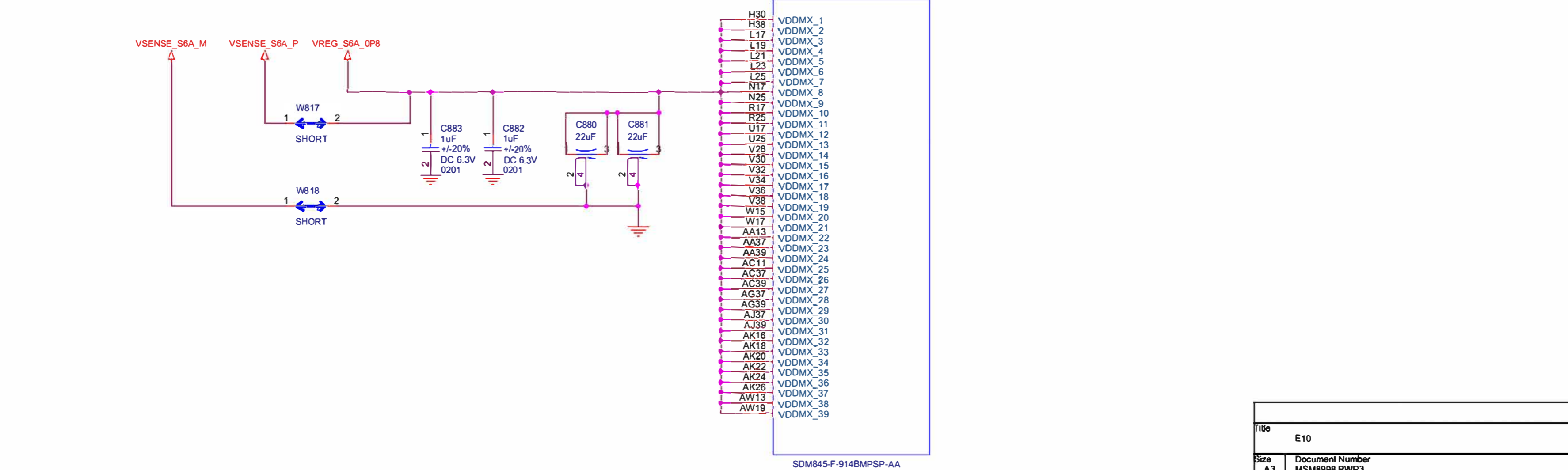
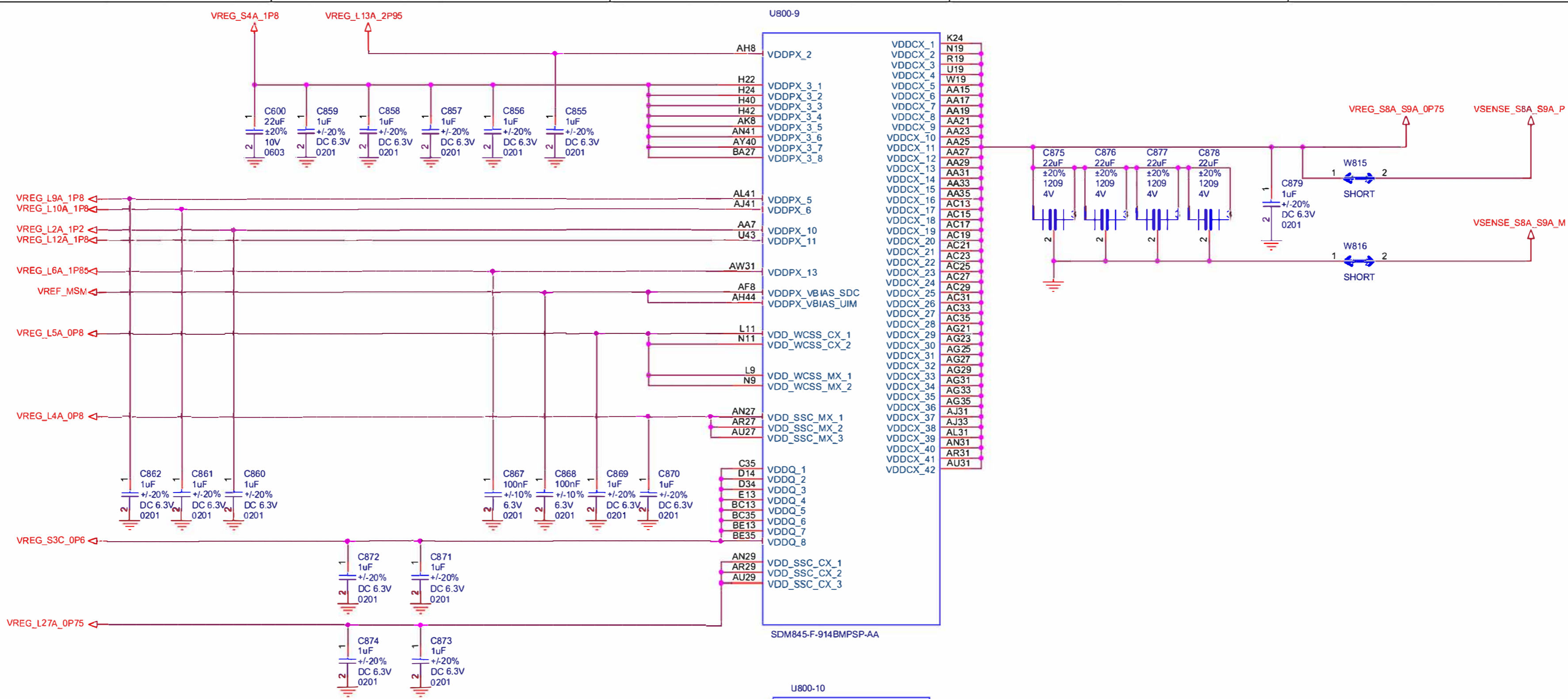

Title		E10
Size	Document Number	MSM8998 PWR3
A3	Rev	P0

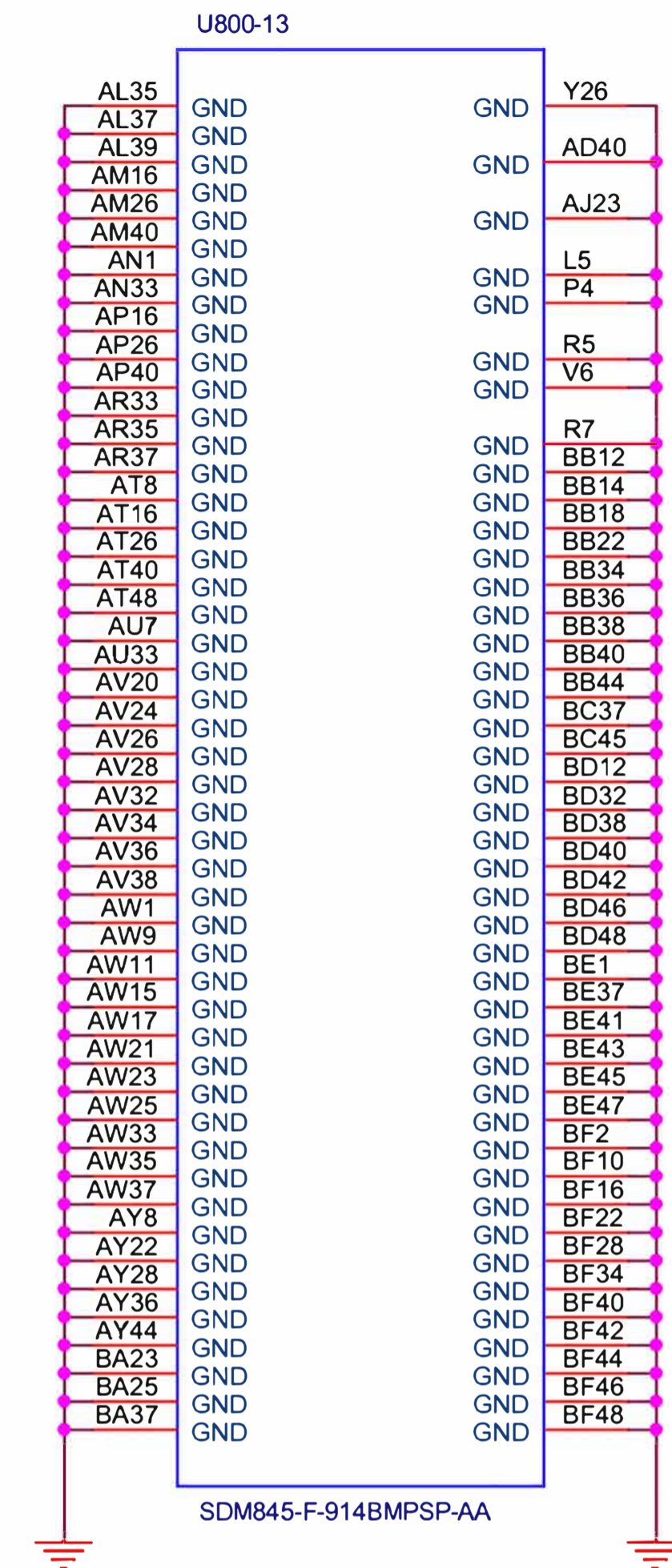
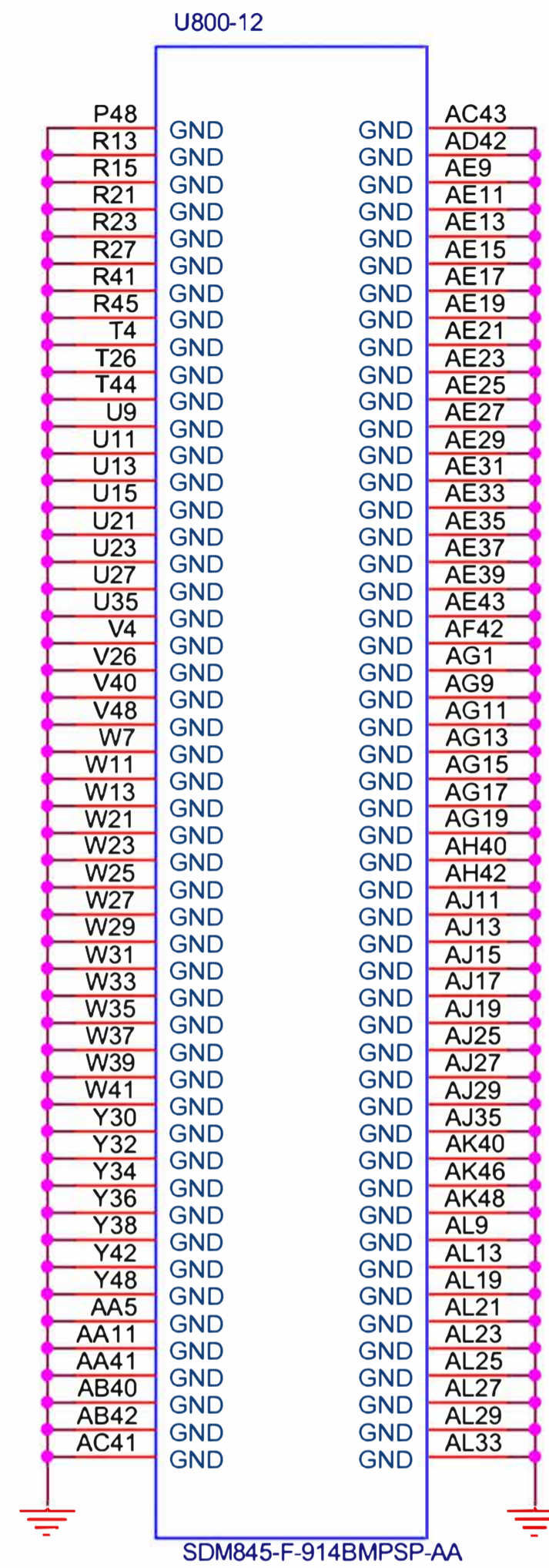
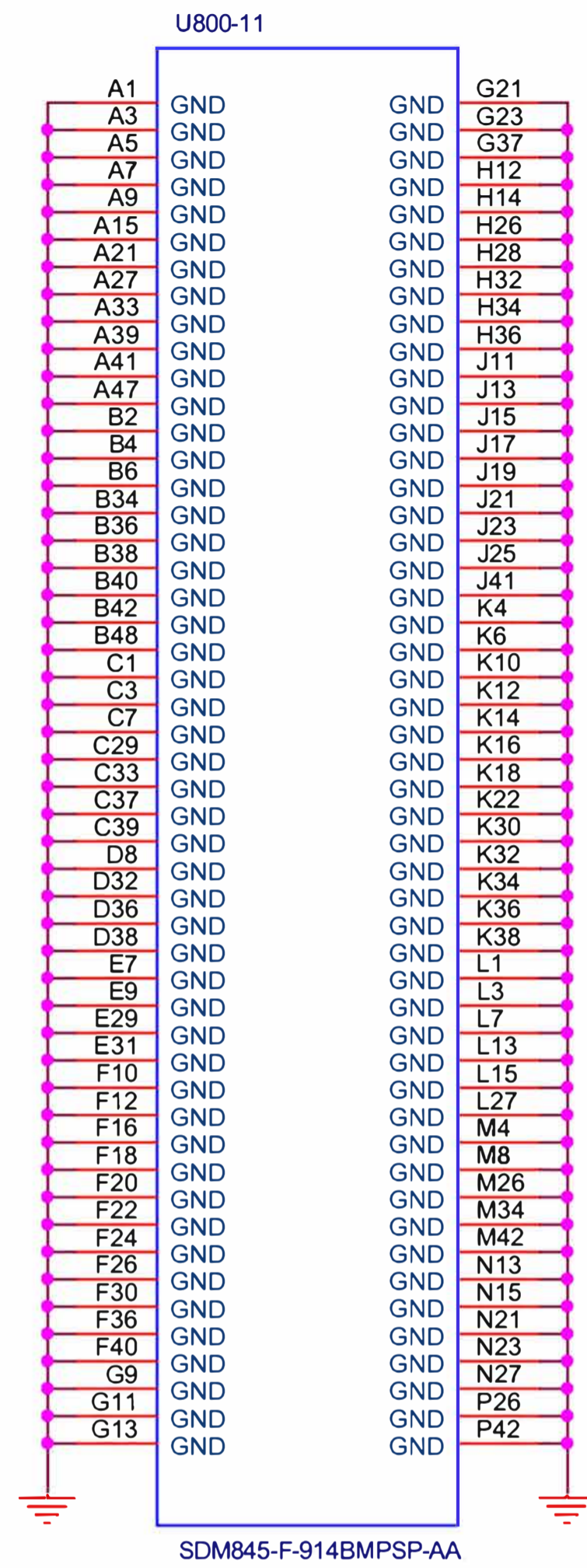

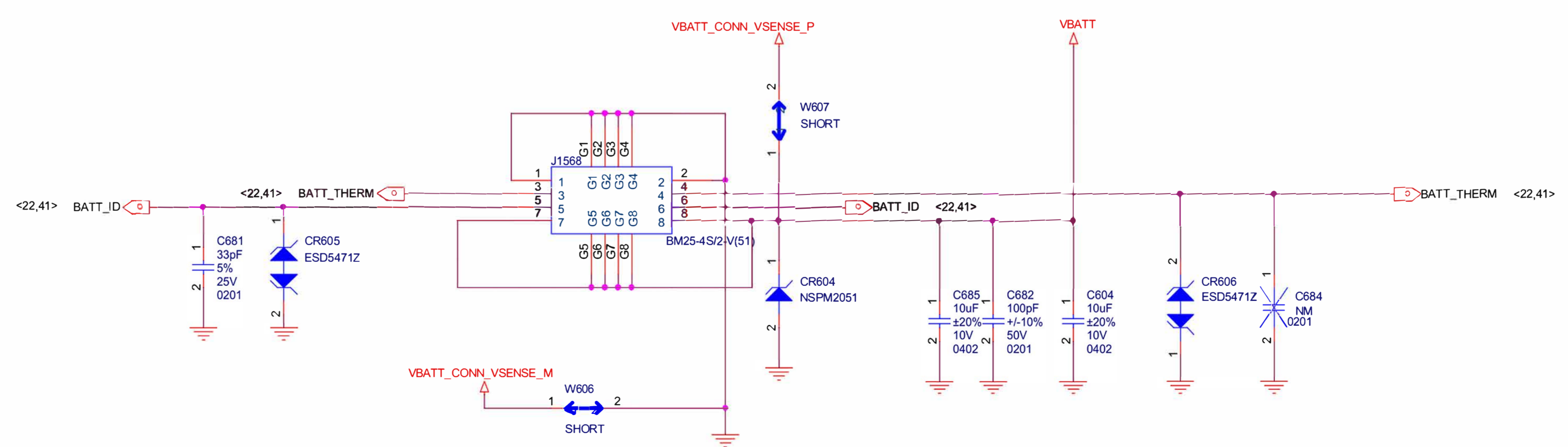
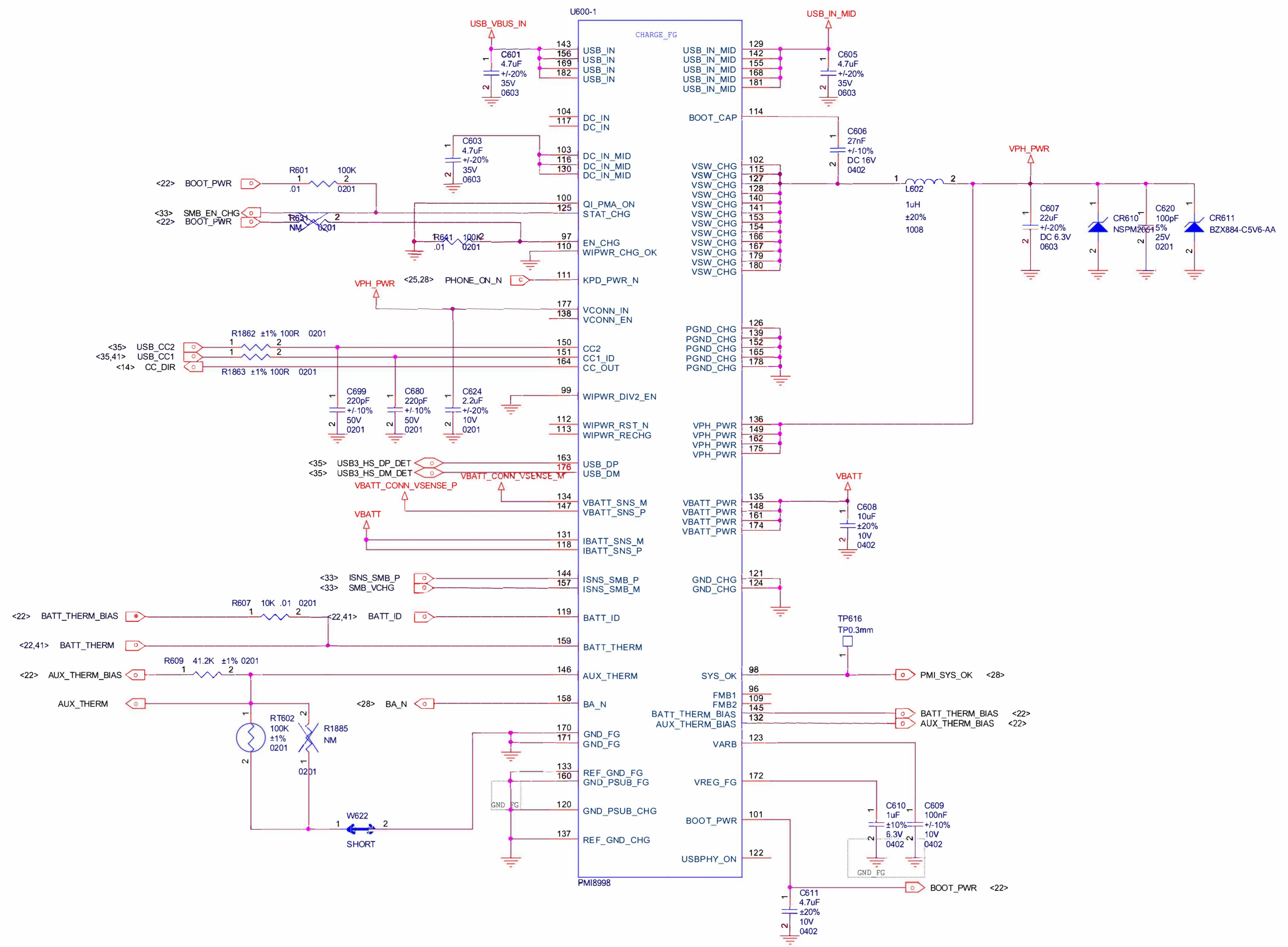

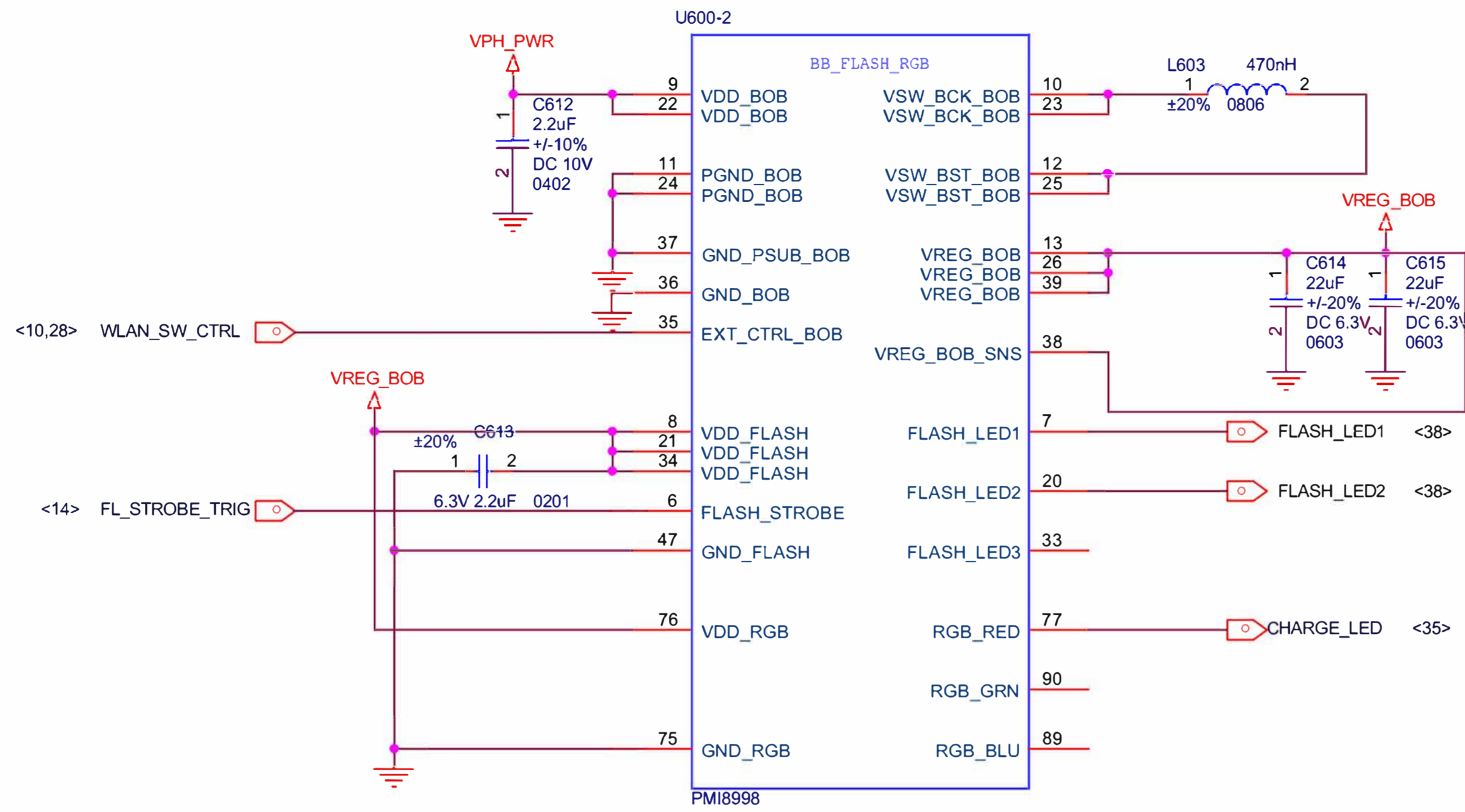

Title		
E10		
Size	Document Number	Rev
A3	PMI8998 BB FLASH RGB	P0
Date:	Friday, May 11, 2018	Sheet 23 of 40

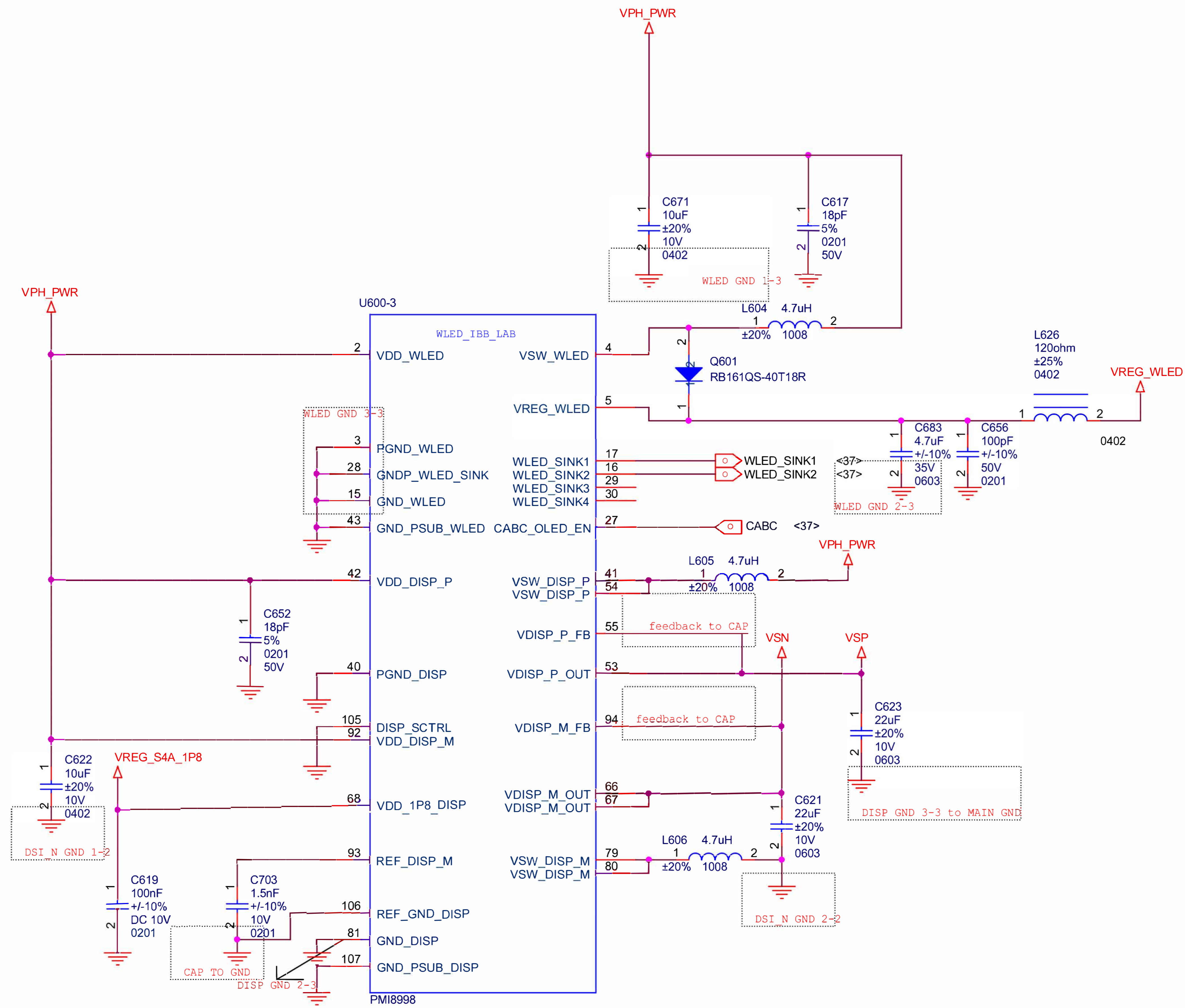

Title		
E10		
Size	Document Number	Rev
A3	PMI8998 WLED IBB LAD	P0
Date:	Friday, May 11, 2018	Sheet 24 of 40



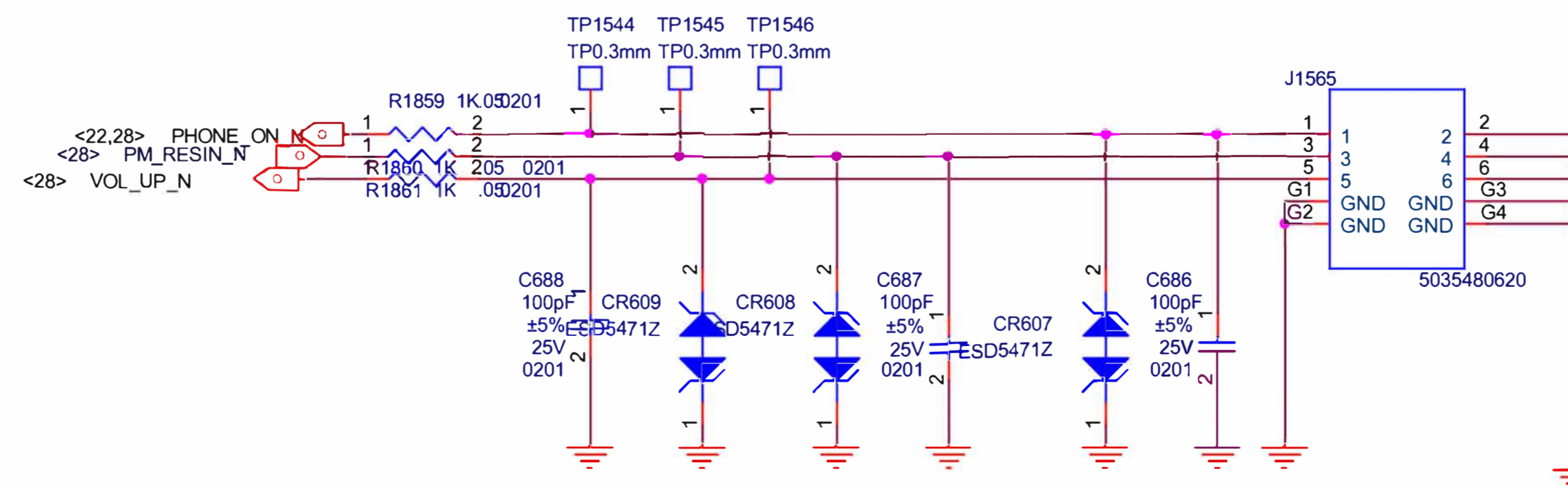
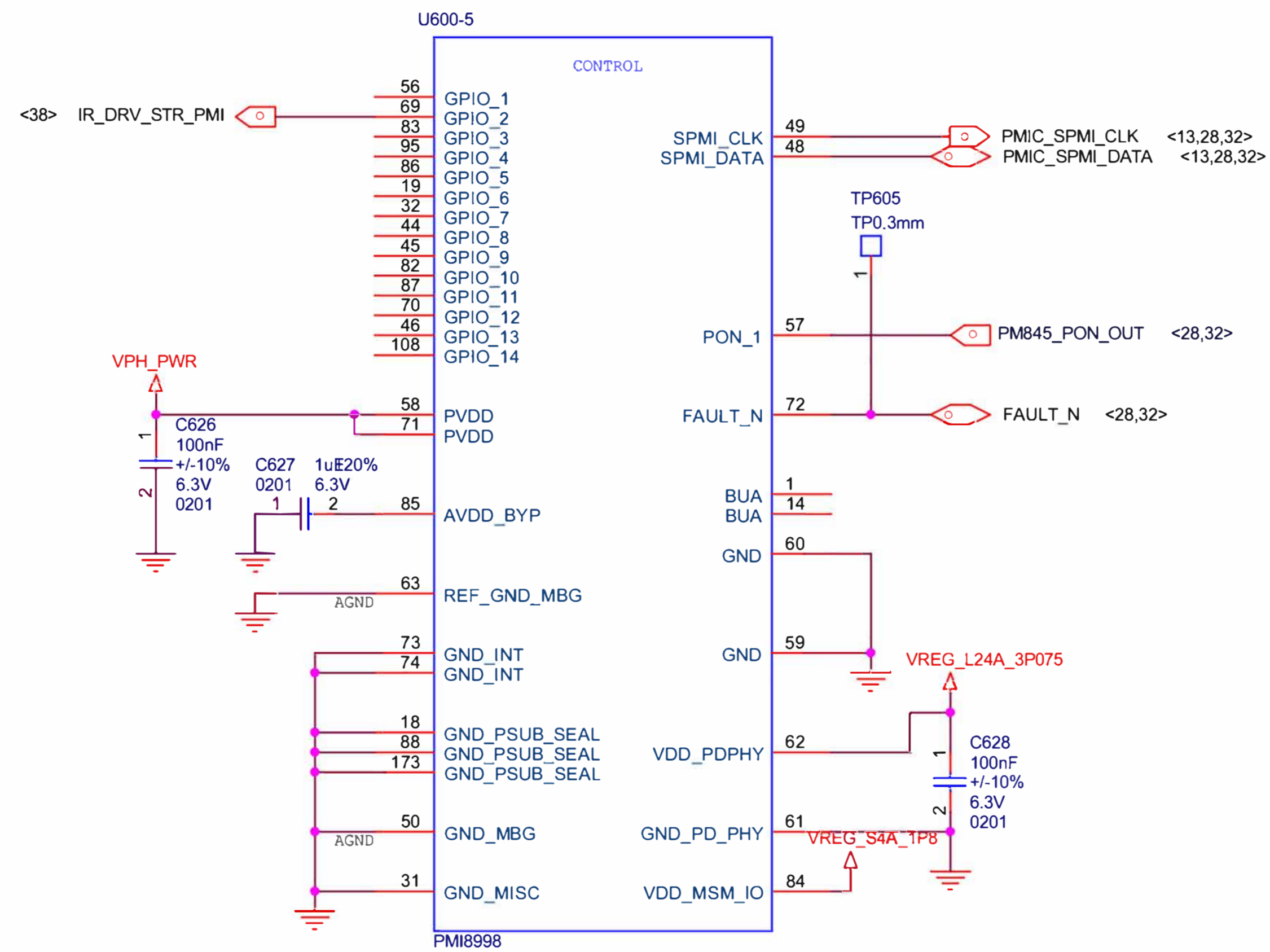
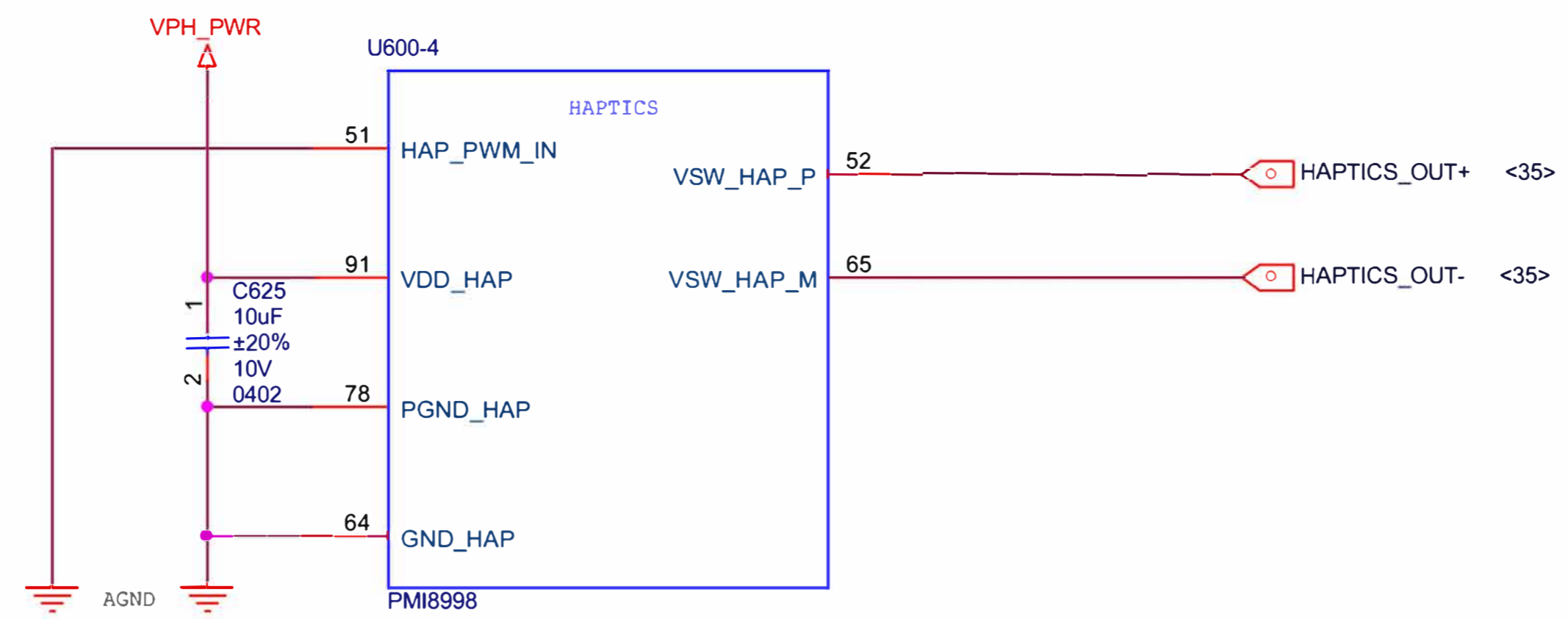

Title		E10
Size	Document Number	Rev
A3	PM18998 HAPTICS&CONTROL	P0
Date:	Friday, May 11, 2018	Sheet 25 of 40

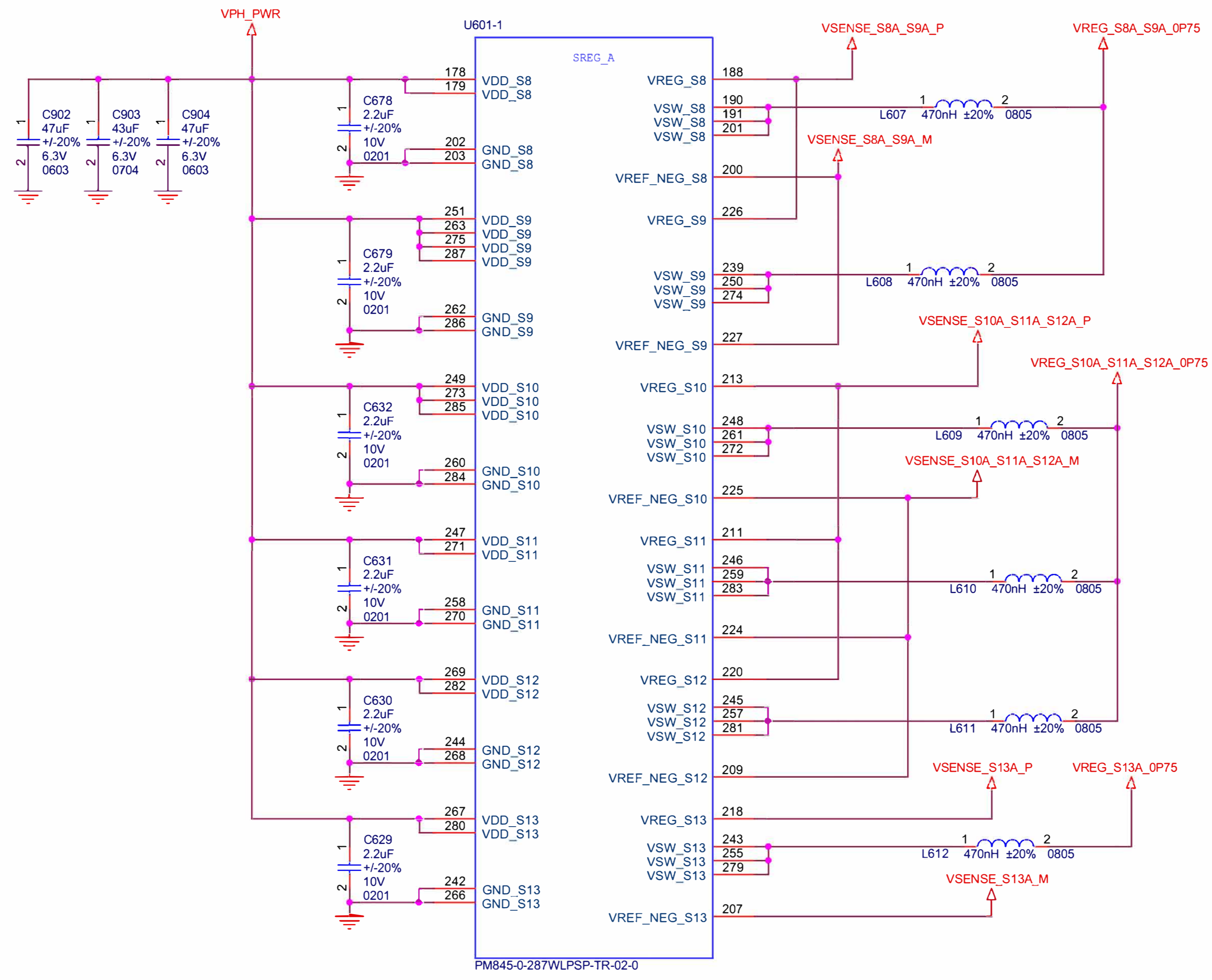

Title		
E10		
Size	Document Number	Rev
A3	PM8998 SREG A	P0
Date:	Friday, May 11, 2018	Sheet 26 of 40

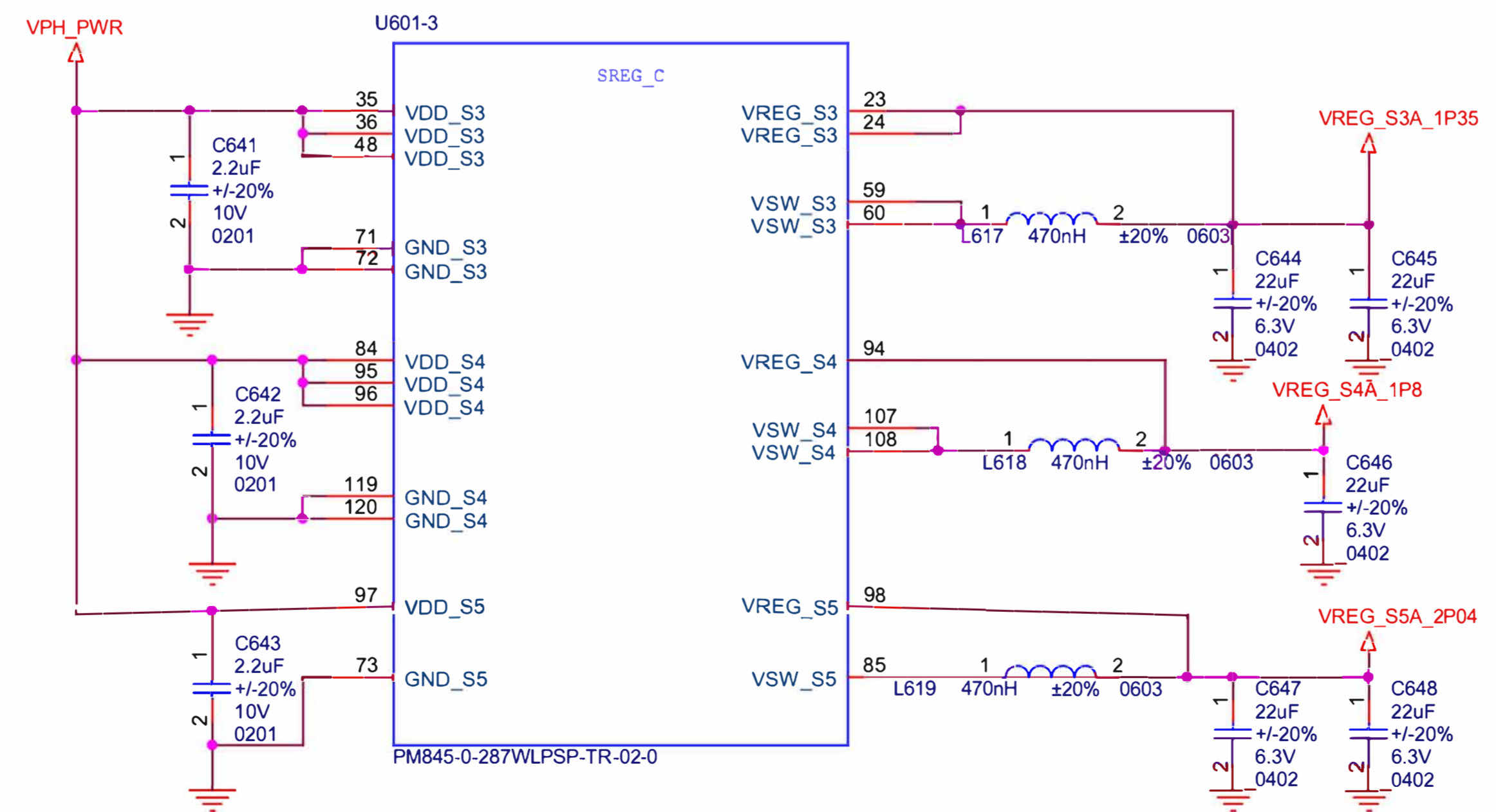
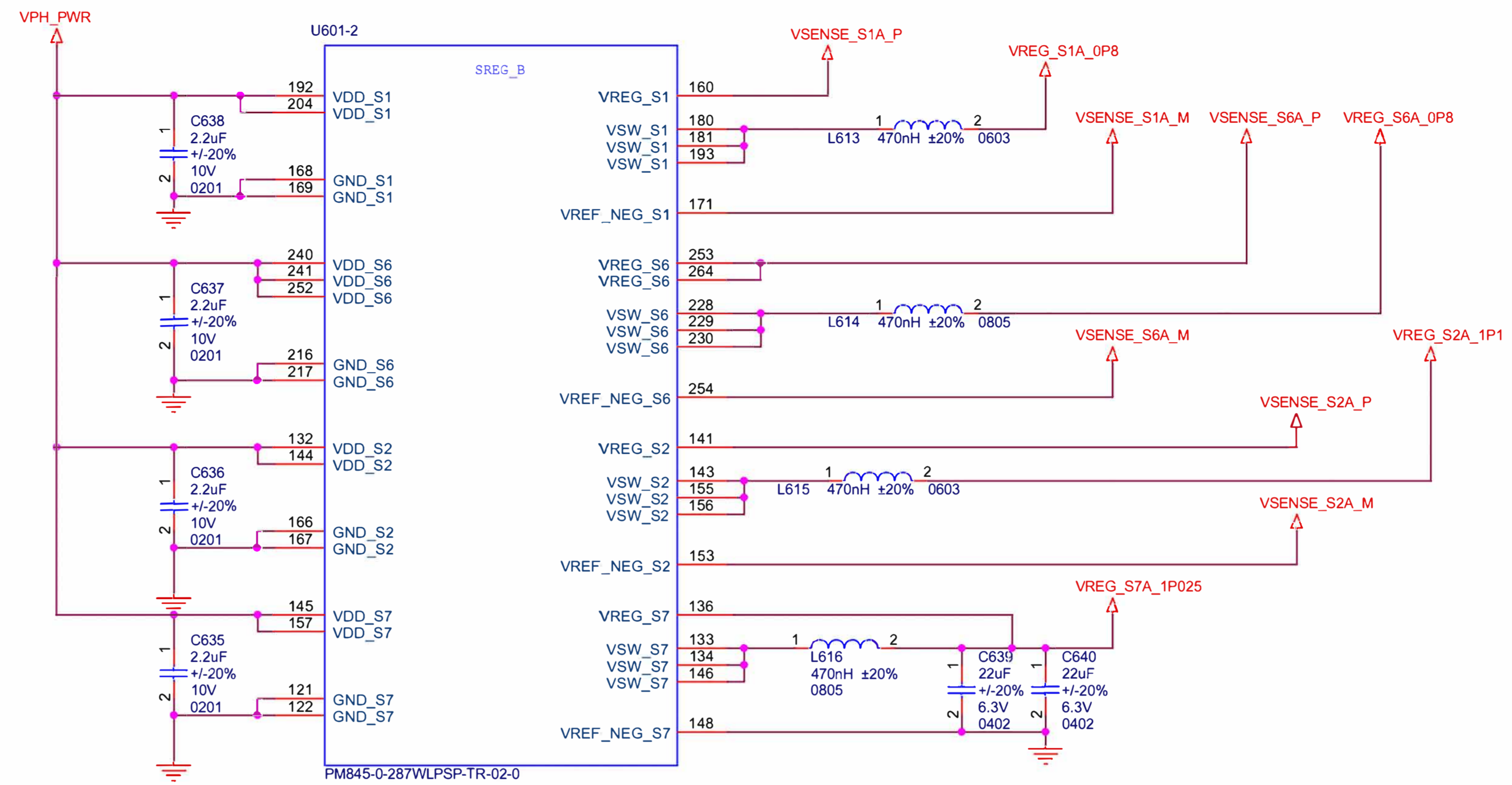

Title		E10
Size	Document Number	Rev
A3	PM8998 SREG B&C	P0
Date:	Friday, May 11, 2018	Sheet 27 of 40

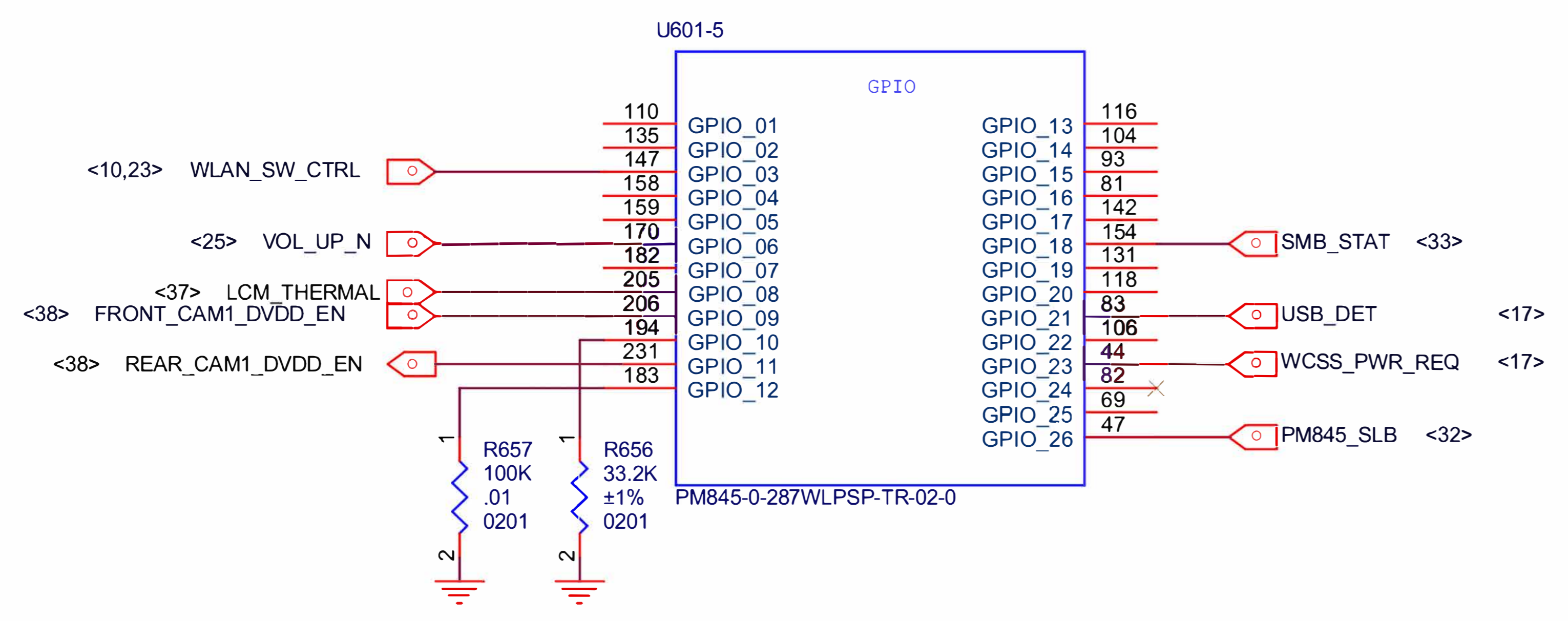
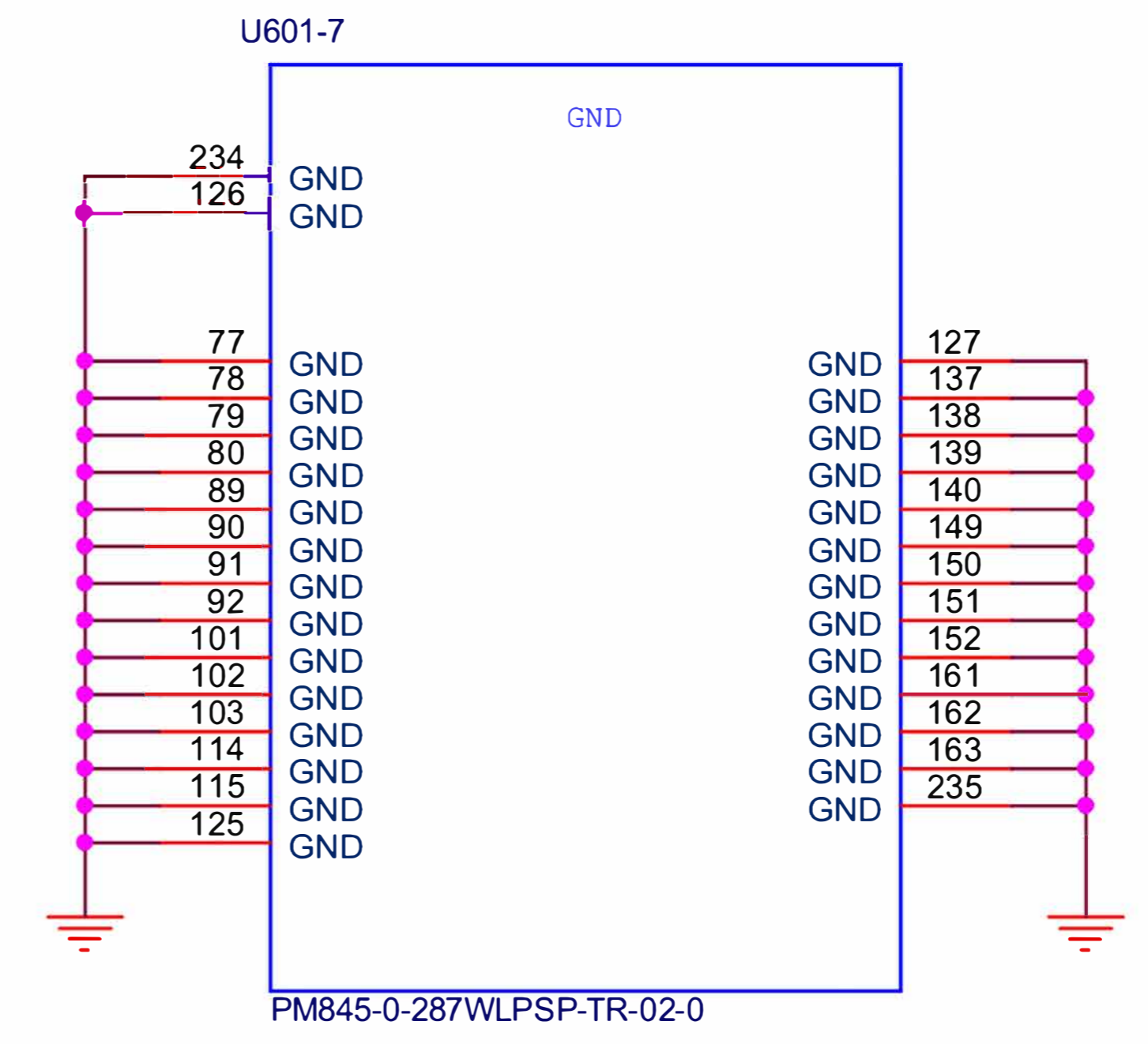
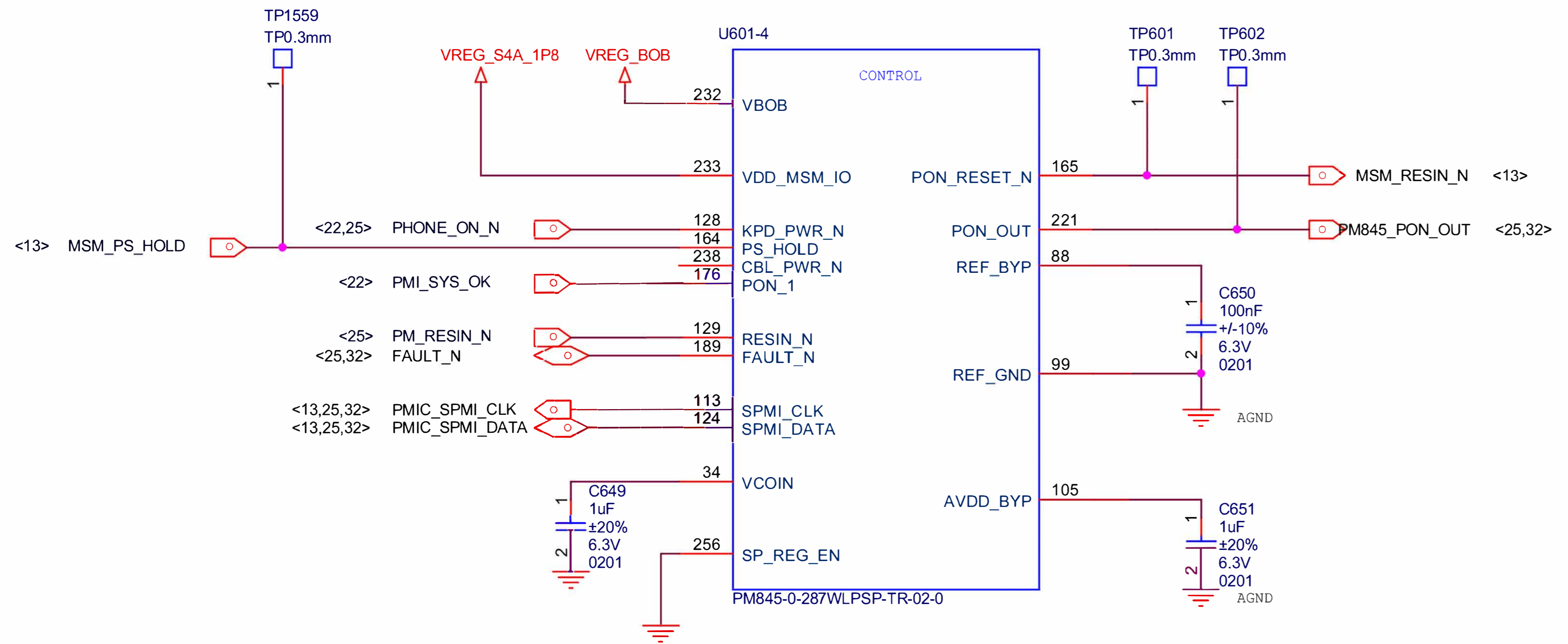

HW Version	HW ID	Project Name	Project ID	Comments
P0	R656_AMUX3(PM845_GPIO_10)	E10	R657_AMUX5_GPIO(PM845_GPIO_12)	
P0.5	11kohms	E10	100kohms	
P1	17.8kohms	E10	100kohms	
	24.9kohms	E10	100kohms	

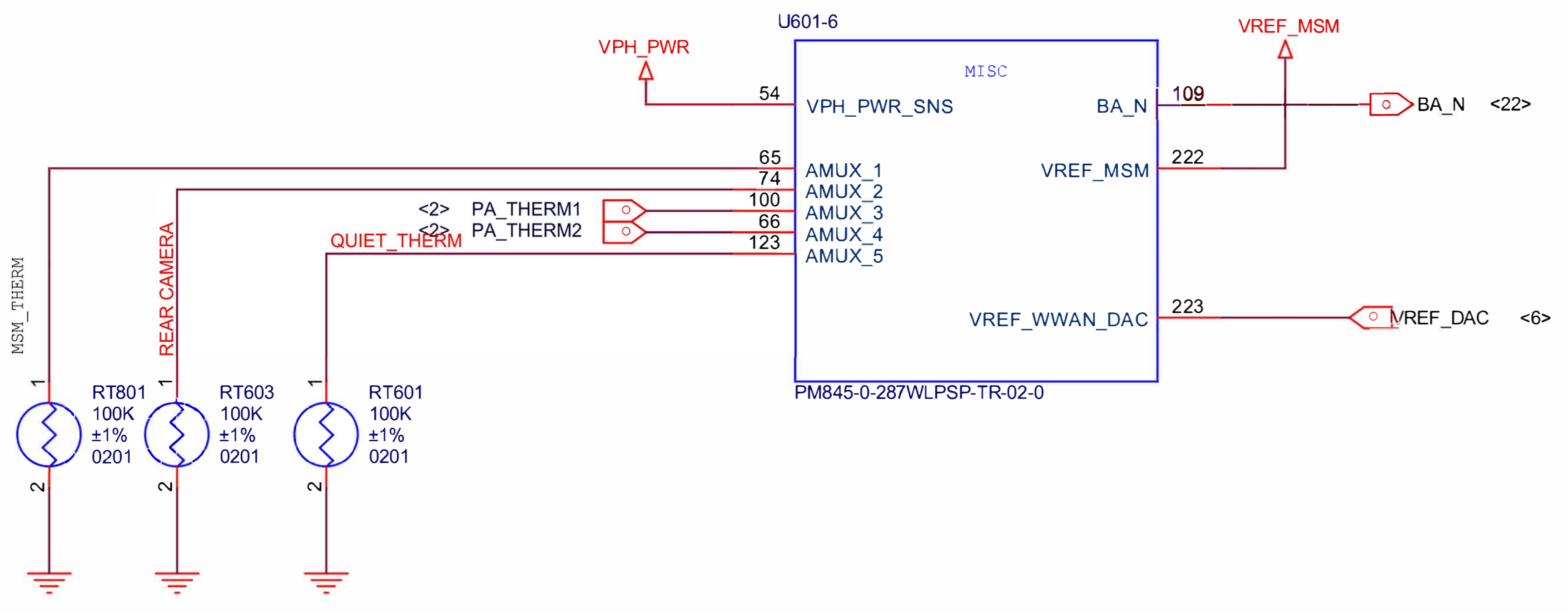

Title		
E10		
Size	Document Number	Rev
A3	PM8998 CONTROL&GPIO&MICS	P0
Date:	Friday, May 11, 2018	Sheet 28 of 40

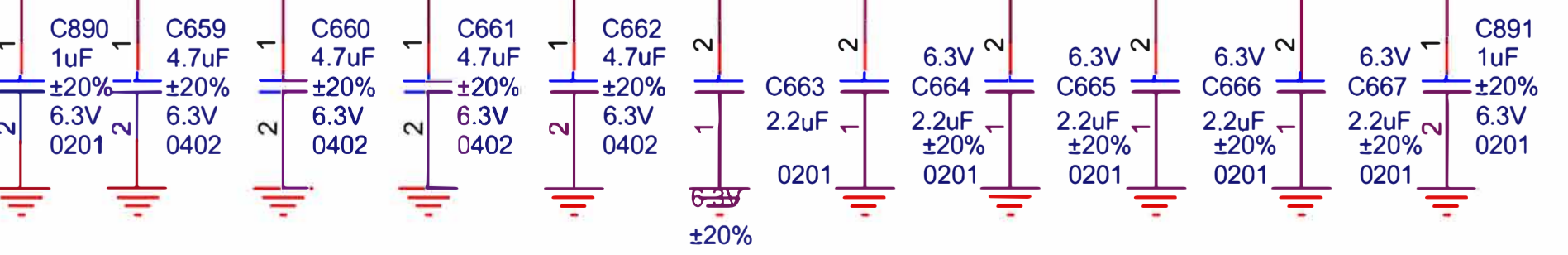
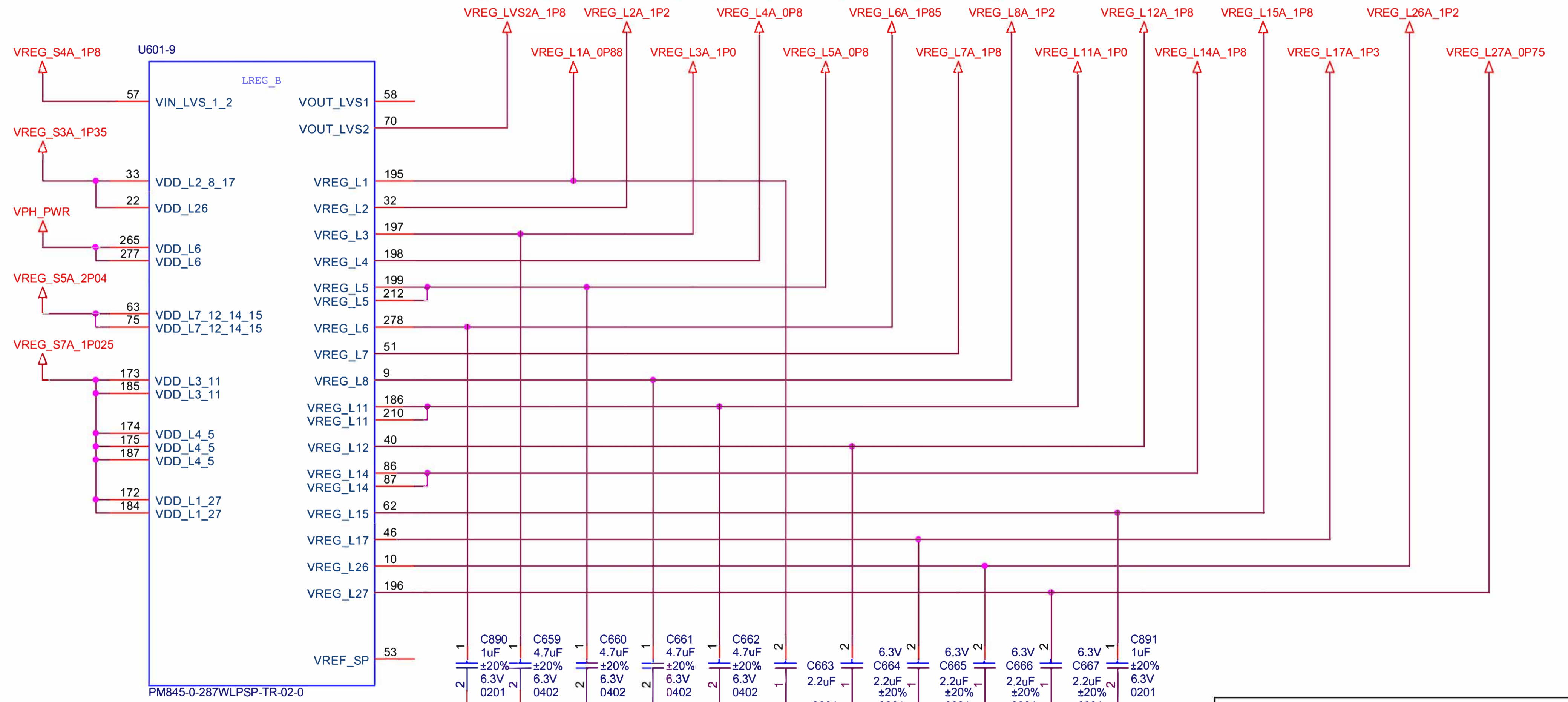
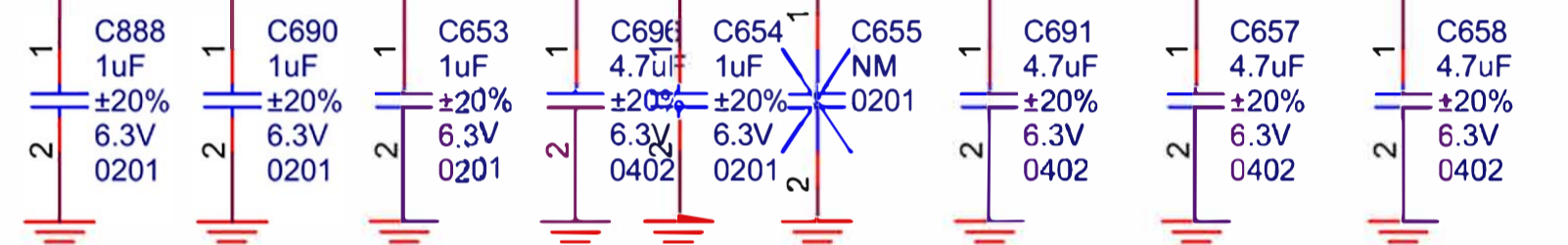
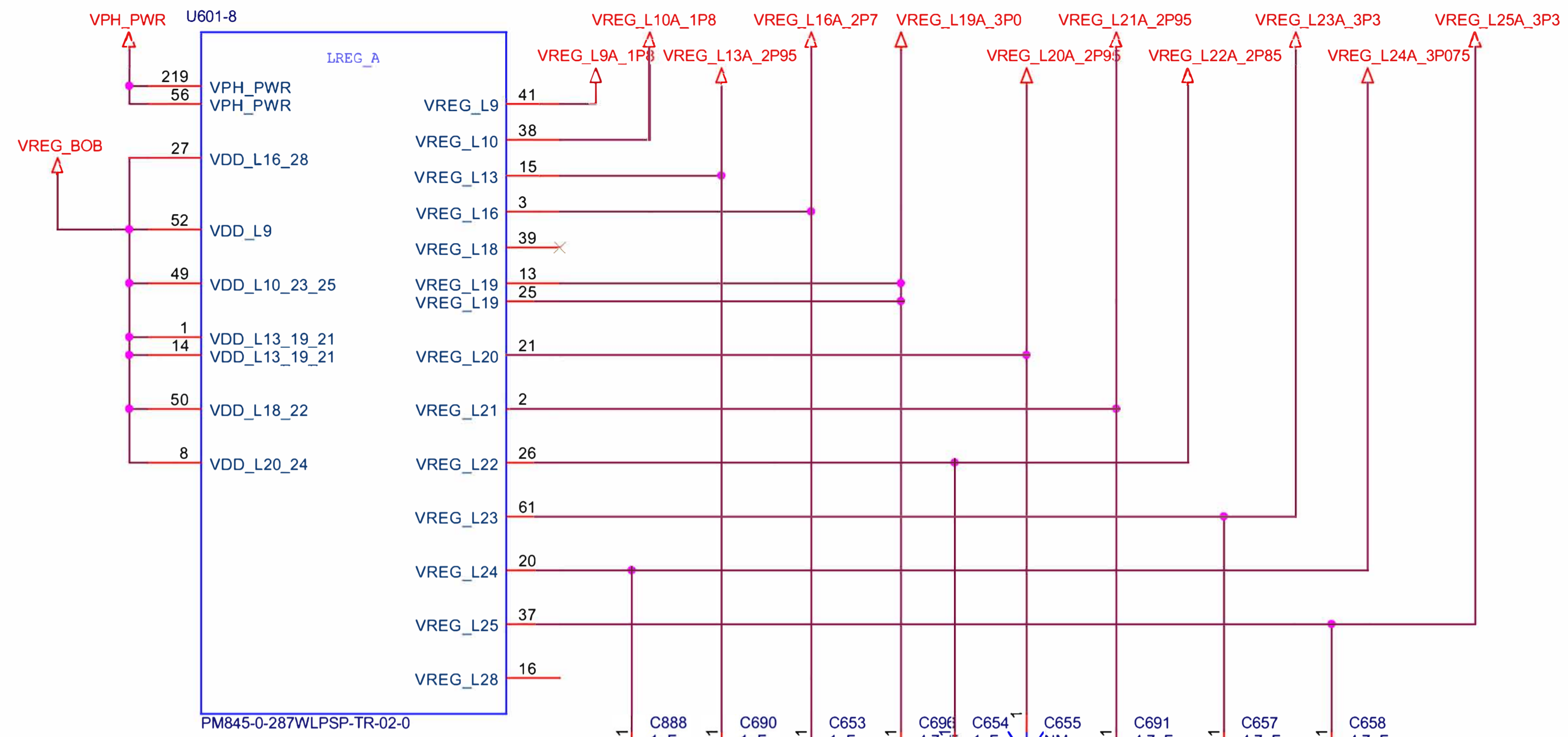

Title		
E10		
Size	Document Number	Rev
A3	PM8998 LREG A&B	P0
Date:	Friday, May 11, 2018	Sheet 29 of 40

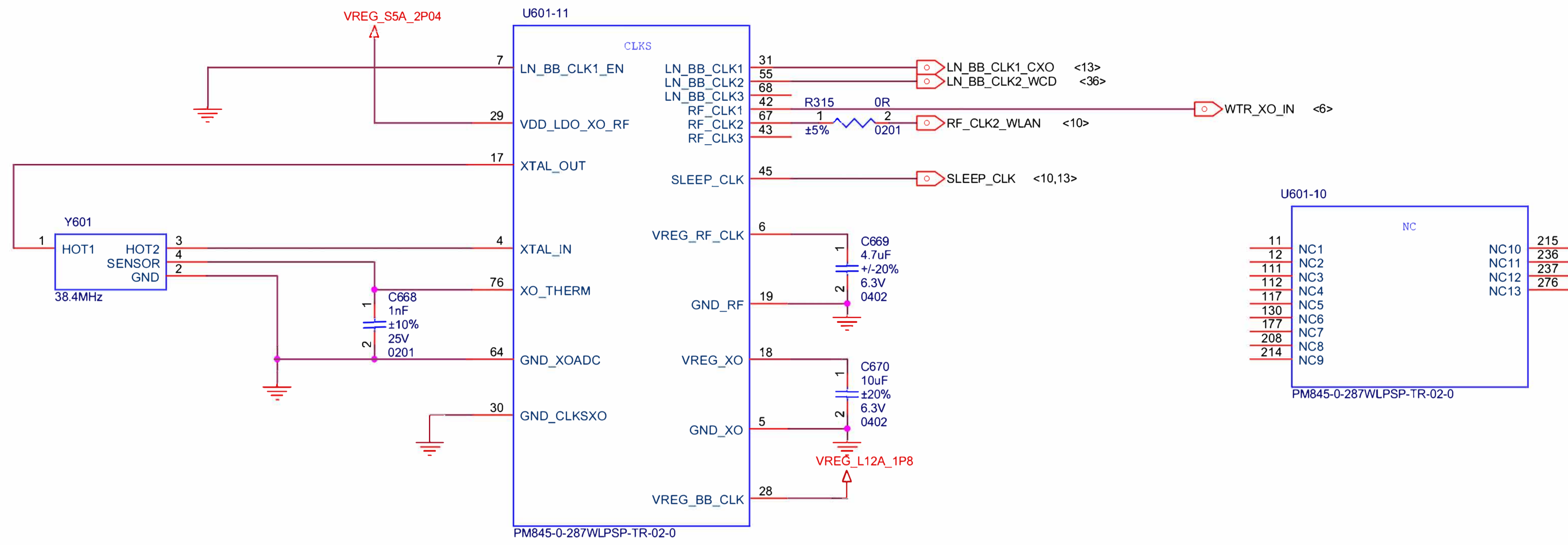

Title		
E10		
Size	Document Number	Rev
A3	PM8998 CLKS	P0
Date:	Friday, May 11, 2018	Sheet 30 of 40

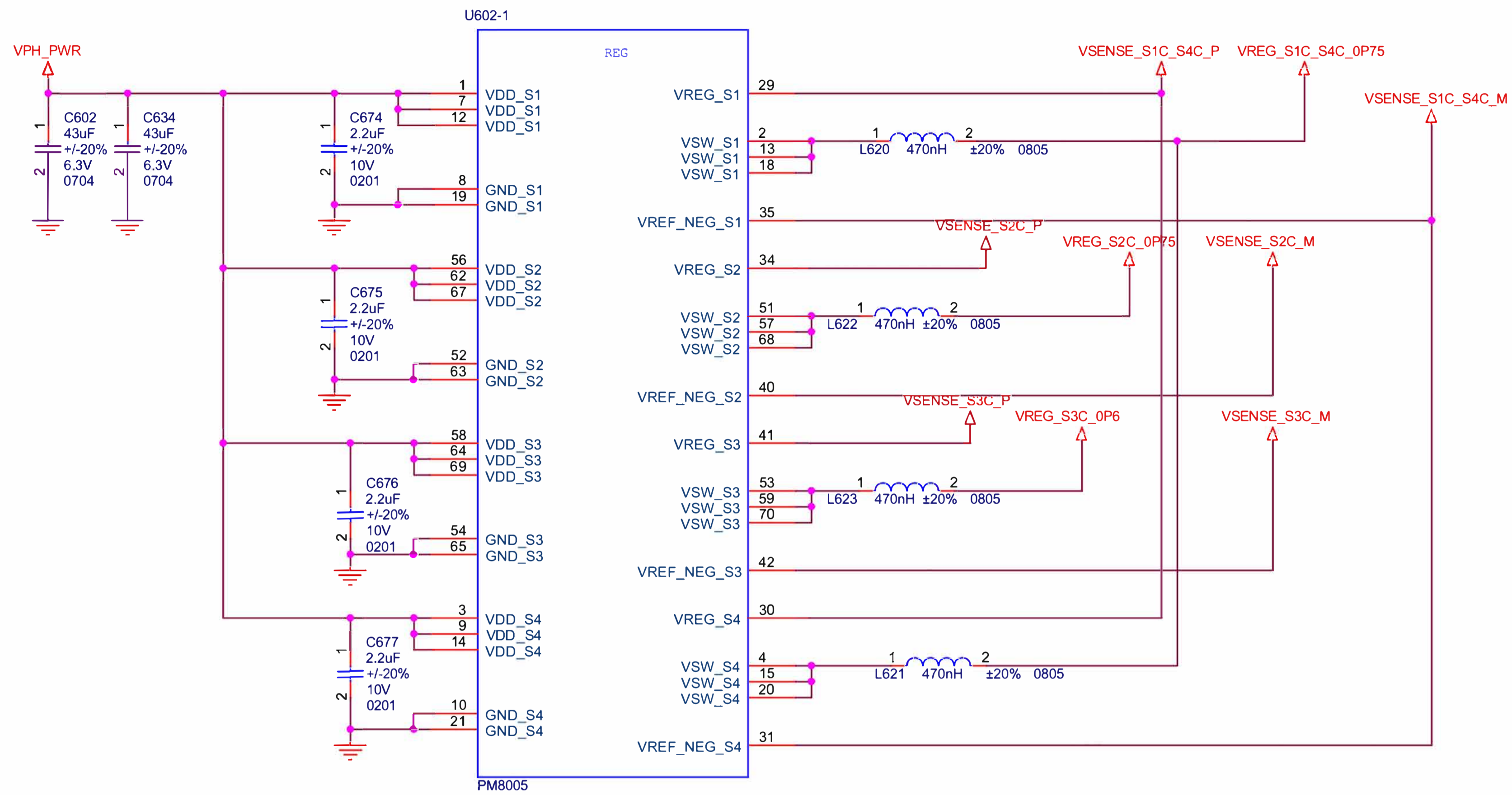

Title		
E10		
Size	Document Number	Rev
A3	PM8005 REG	P0
Date:	Friday, May 11, 2018	Sheet 31 of 40

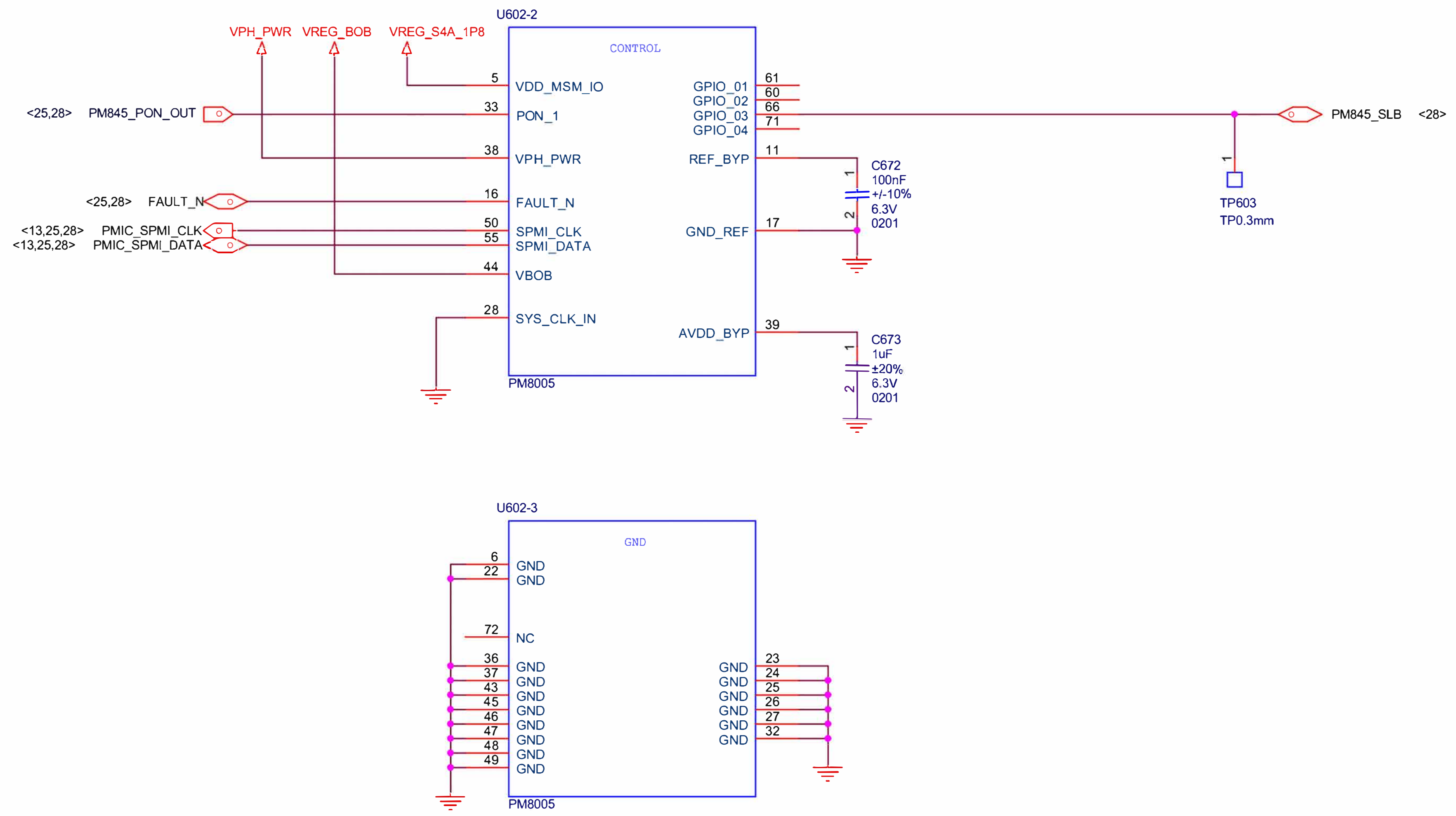

Title		
E10		
Size	Document Number	Rev
A3	PM8005 CONTROL&GND	P0



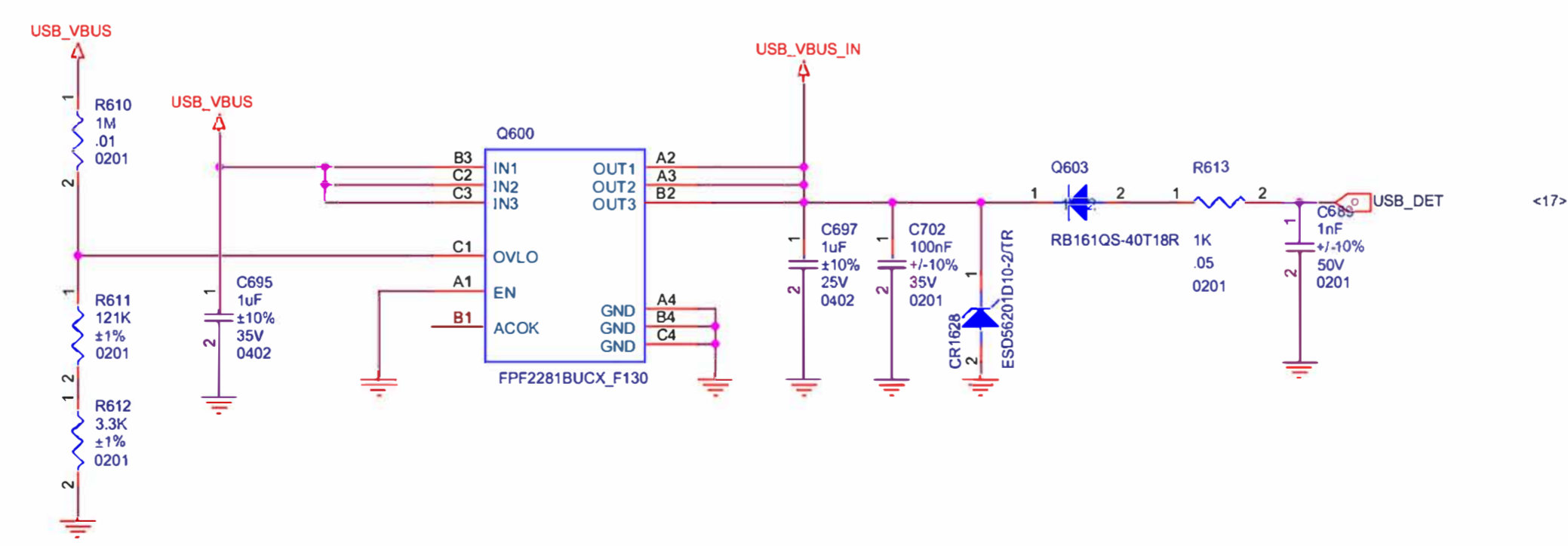
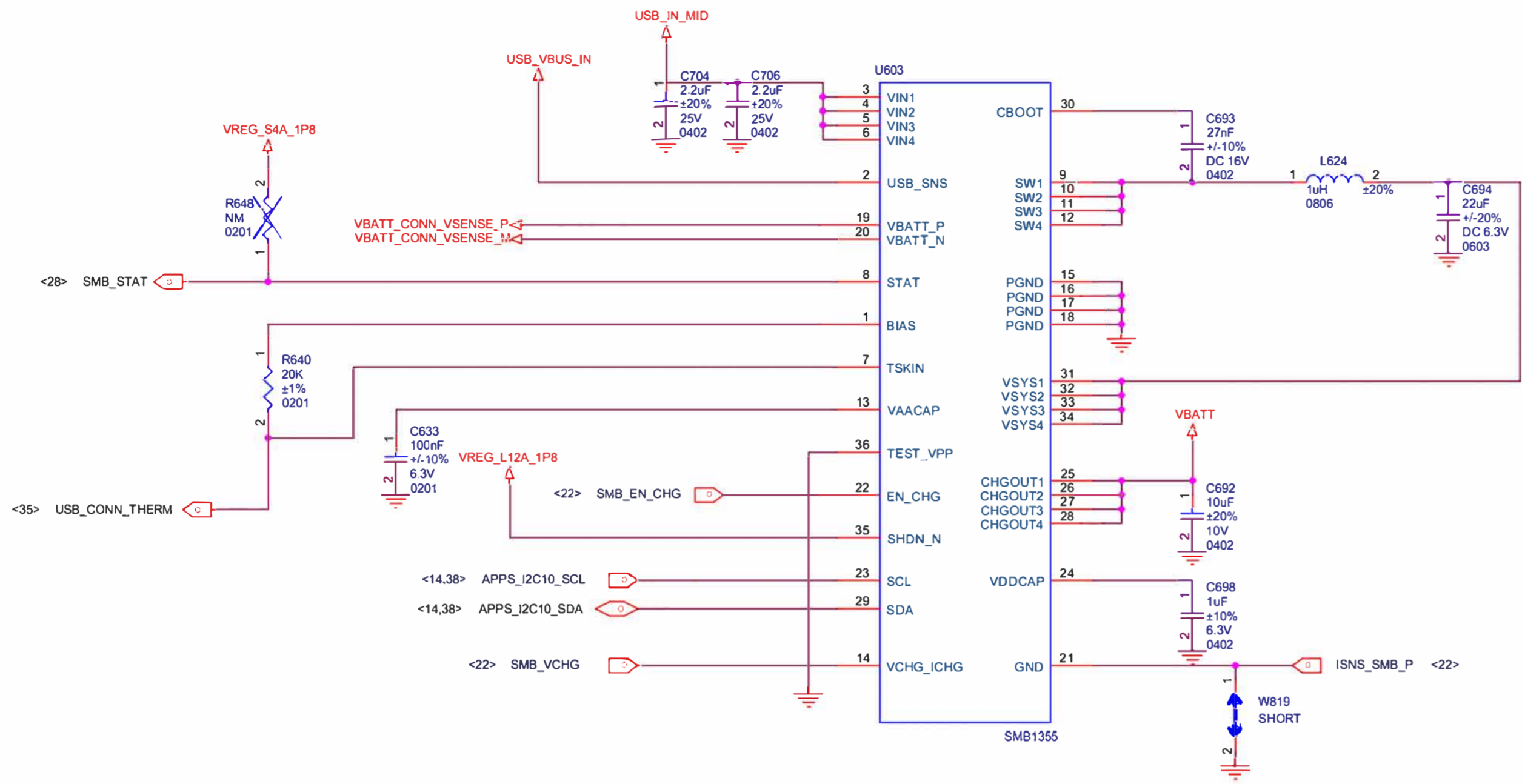

Title		E10
Size	Document Number	Rev
A3	SMB1381	P0
Date:	Friday, May 11, 2018	Sheet 33 of 40

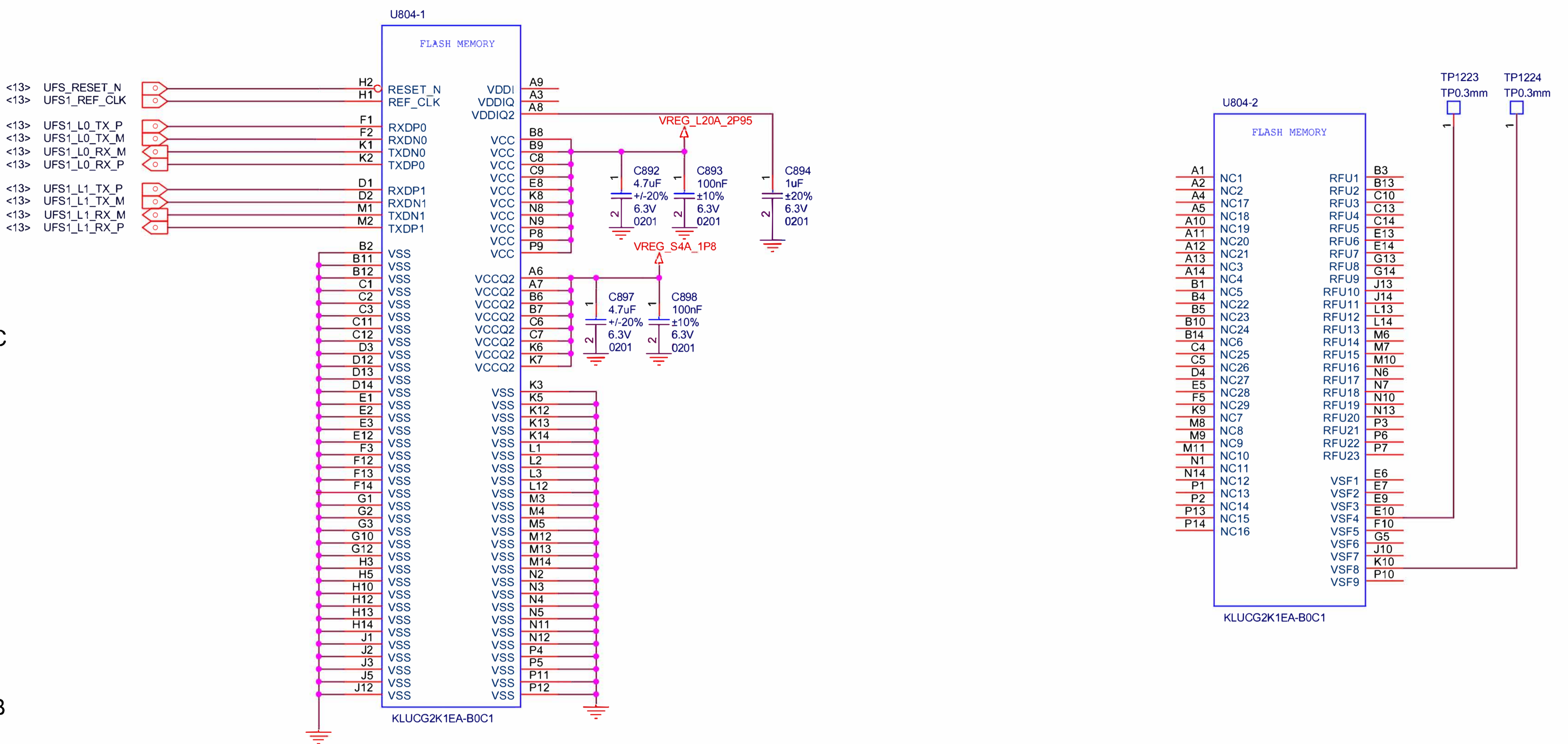

# HEADSET

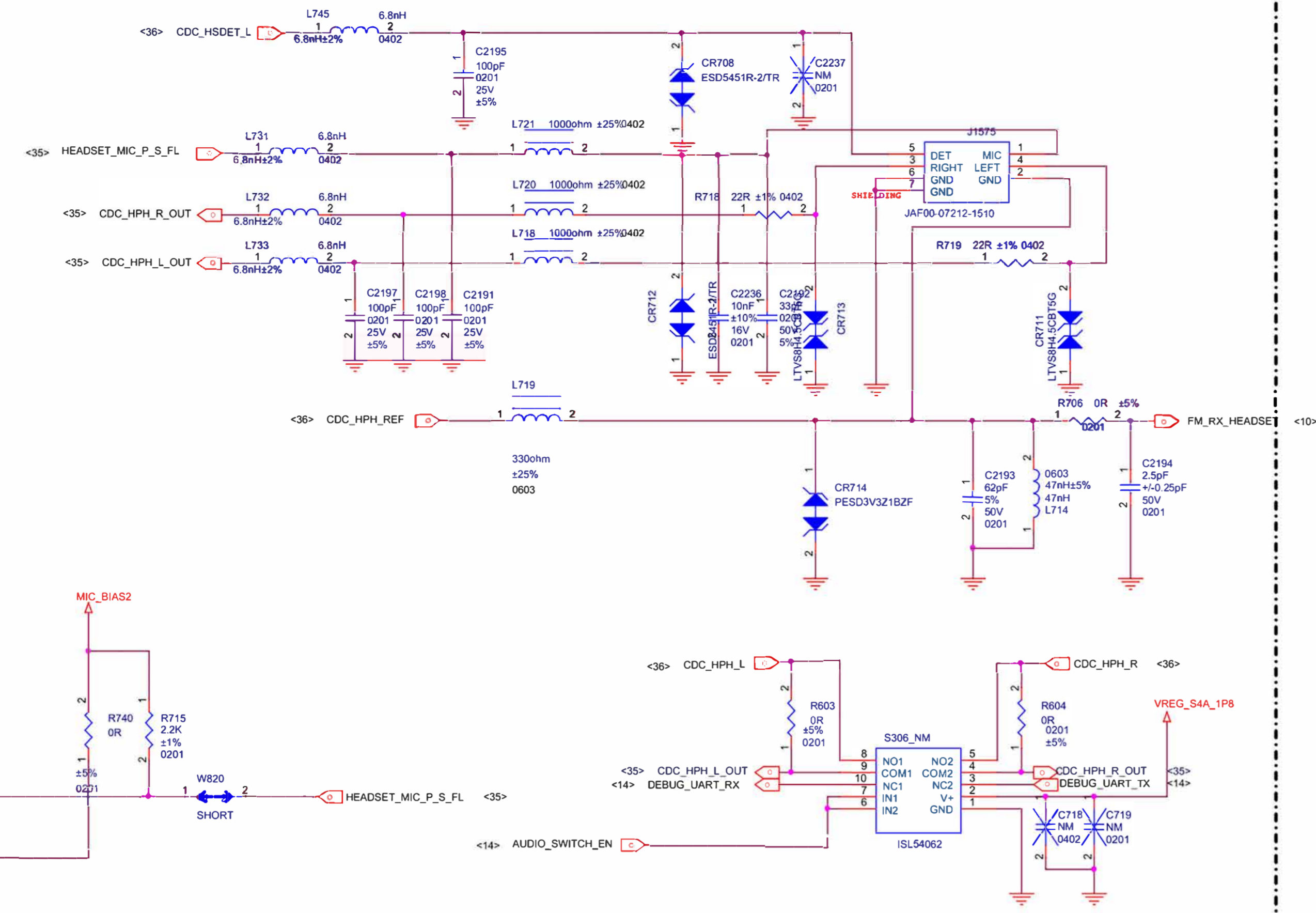

# AUX Mic

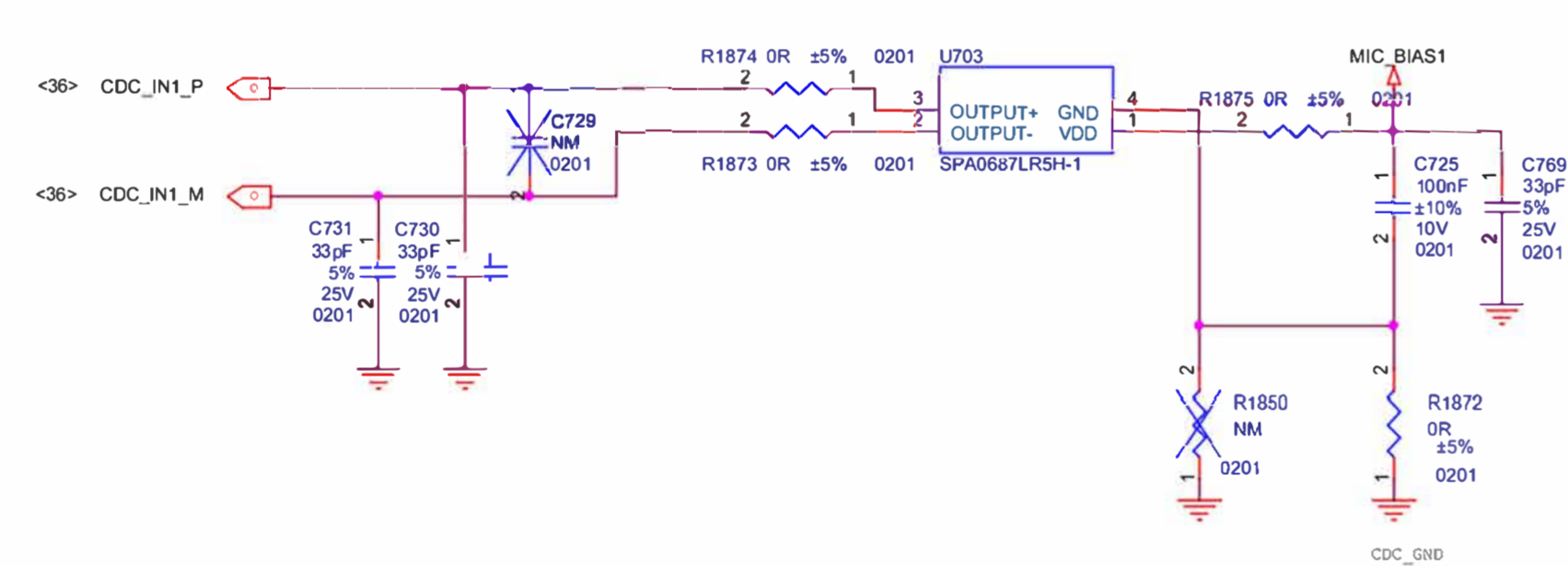

# Receiver PA

R: 0x99 W:0x98

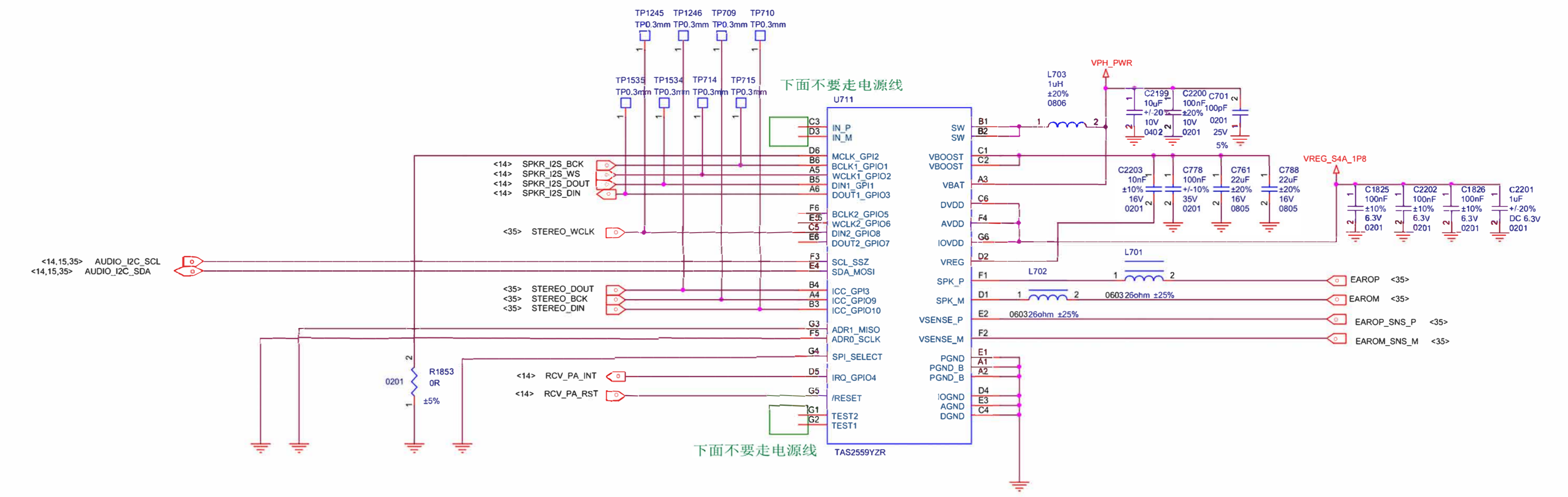

# Speaker PA

R:0x9B W:0x9A

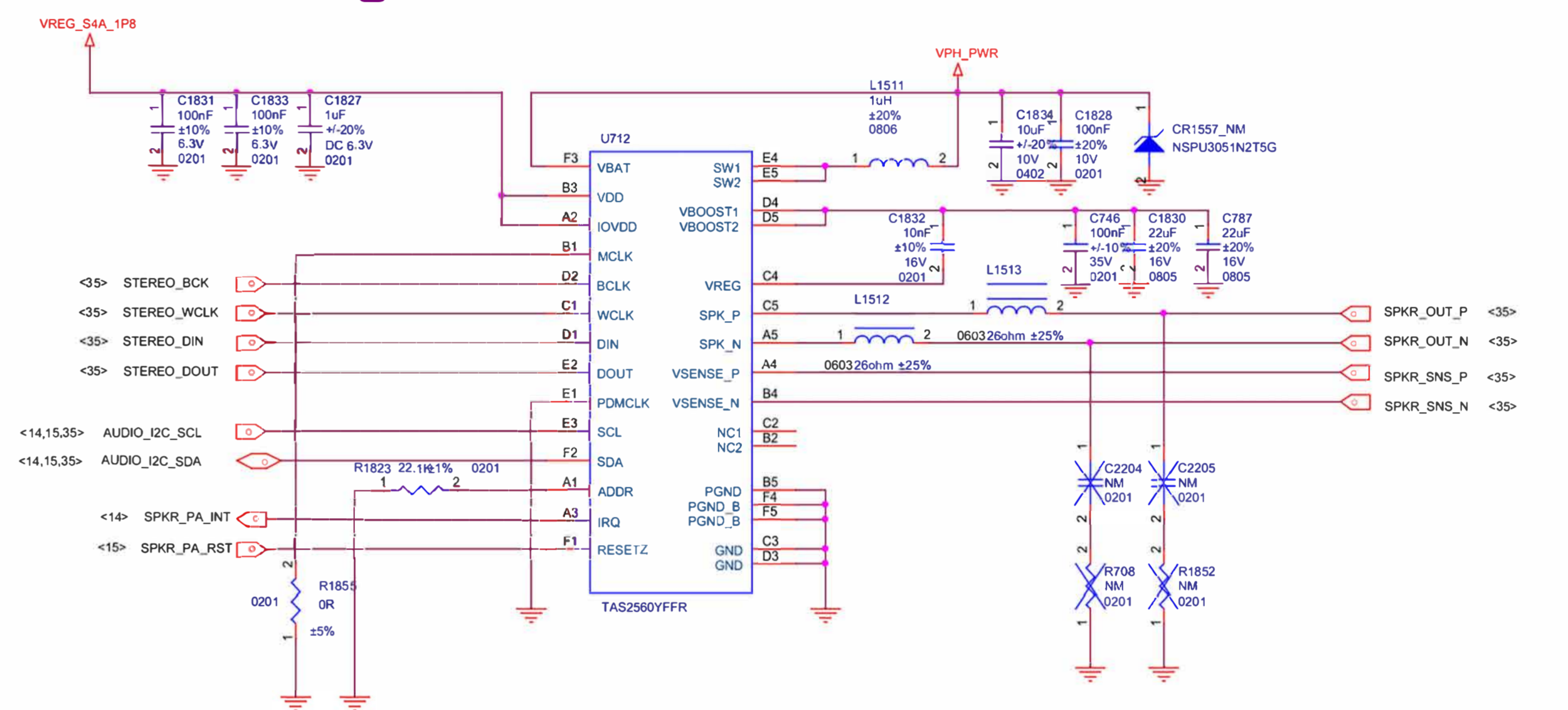

# Receiver

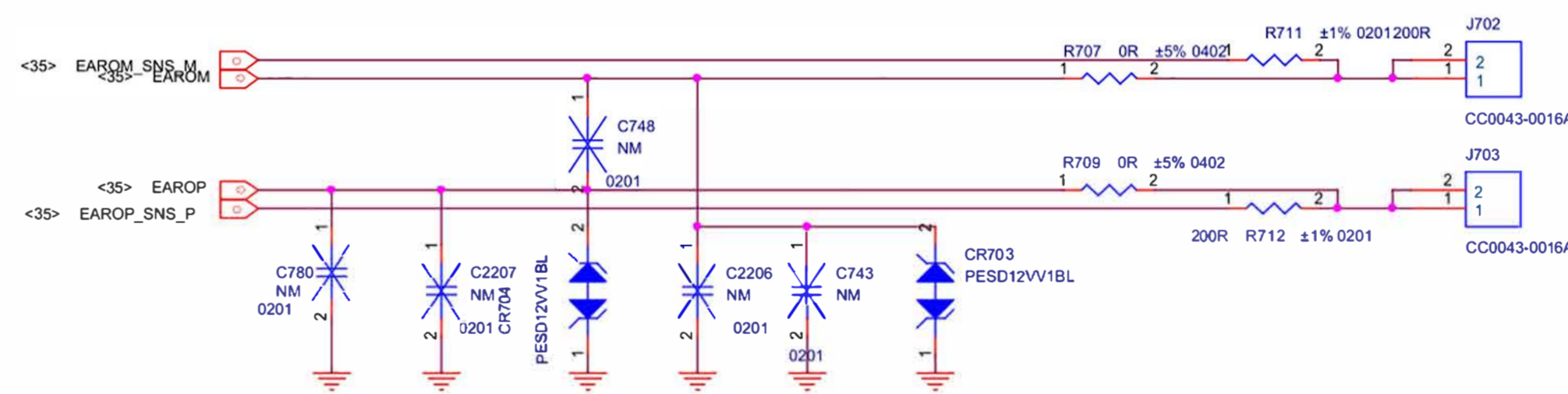

# Bottom fpc Connector

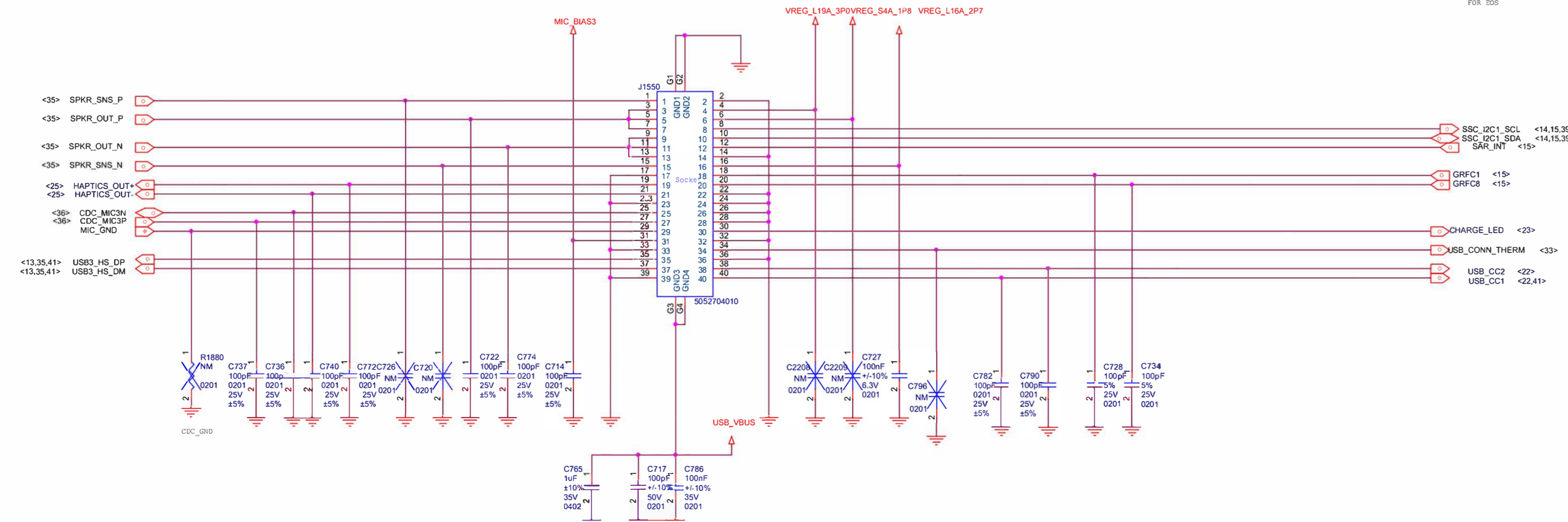

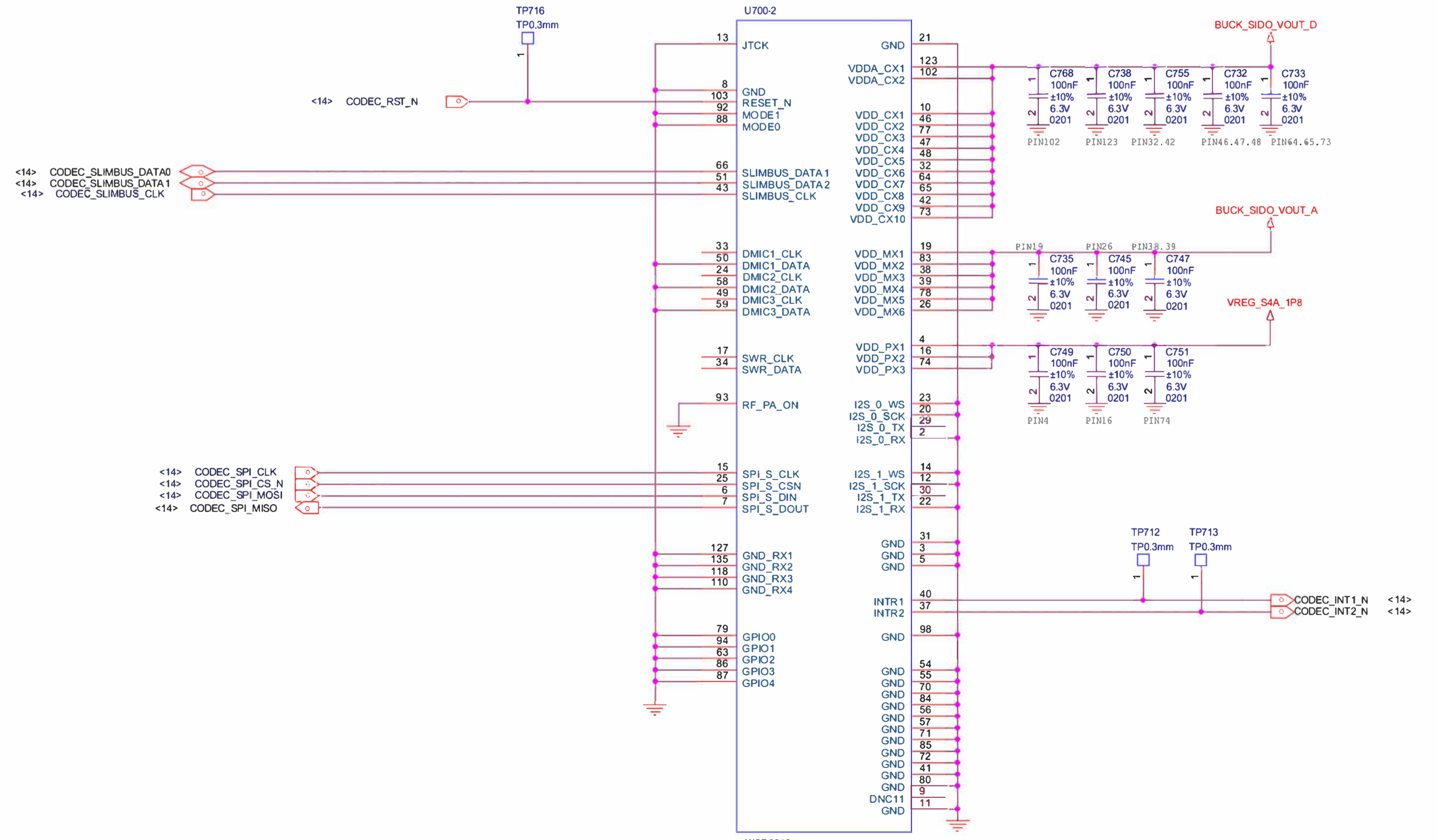
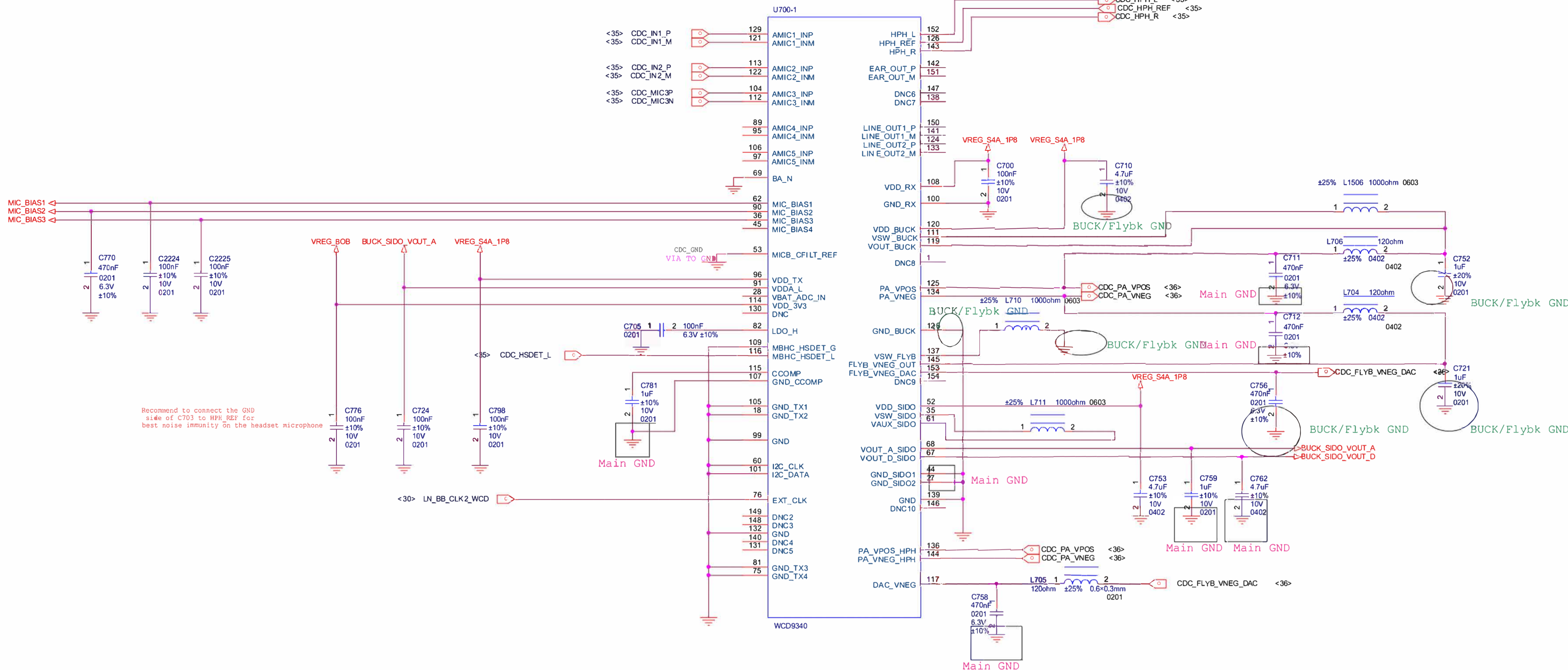

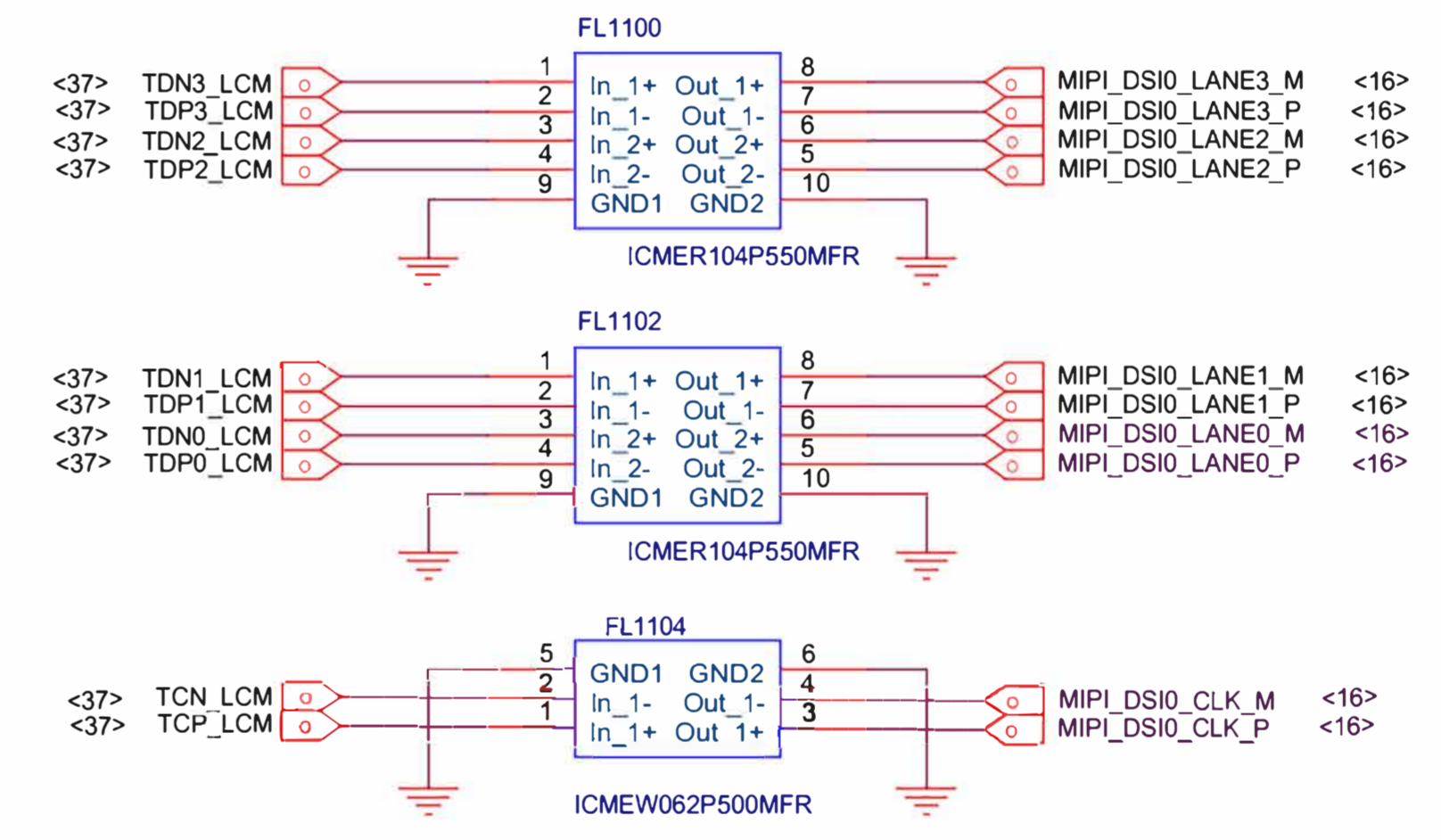
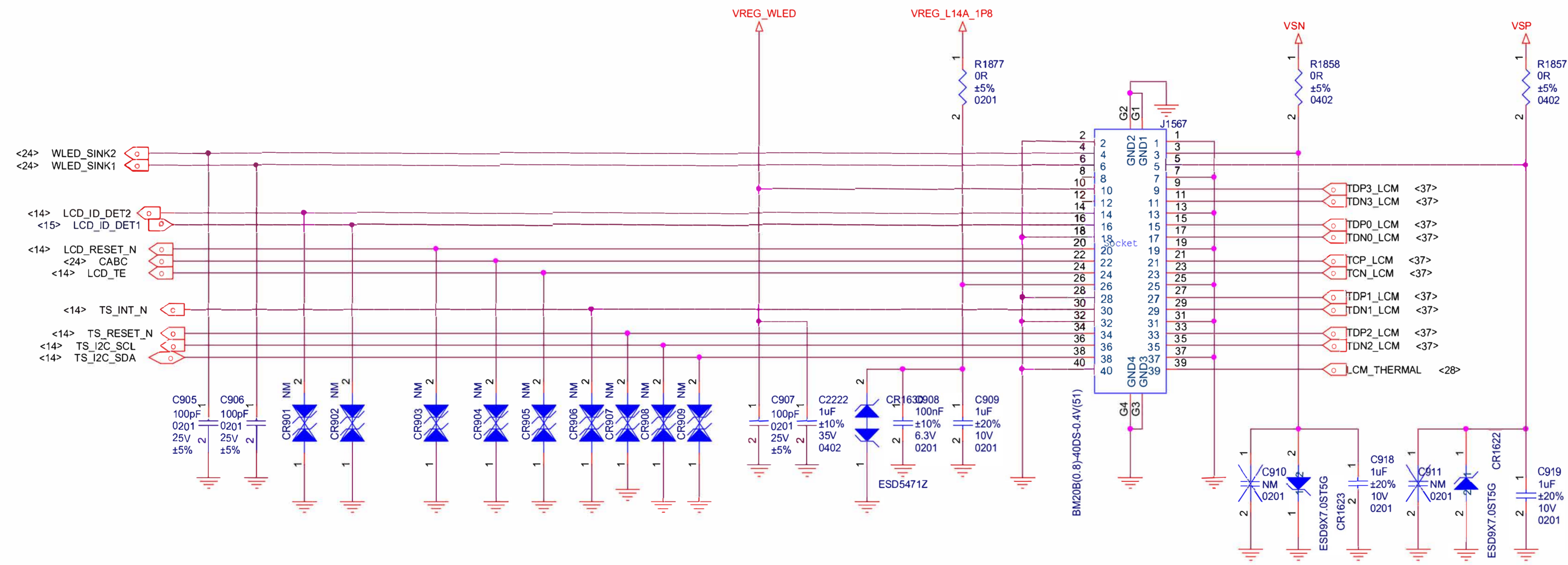

Title		E10
Size	Document Number	Rev
A2	LCD	P0
Date:	Friday, May 11, 2018	Sheet 37 of 40

### CAMERA POWER

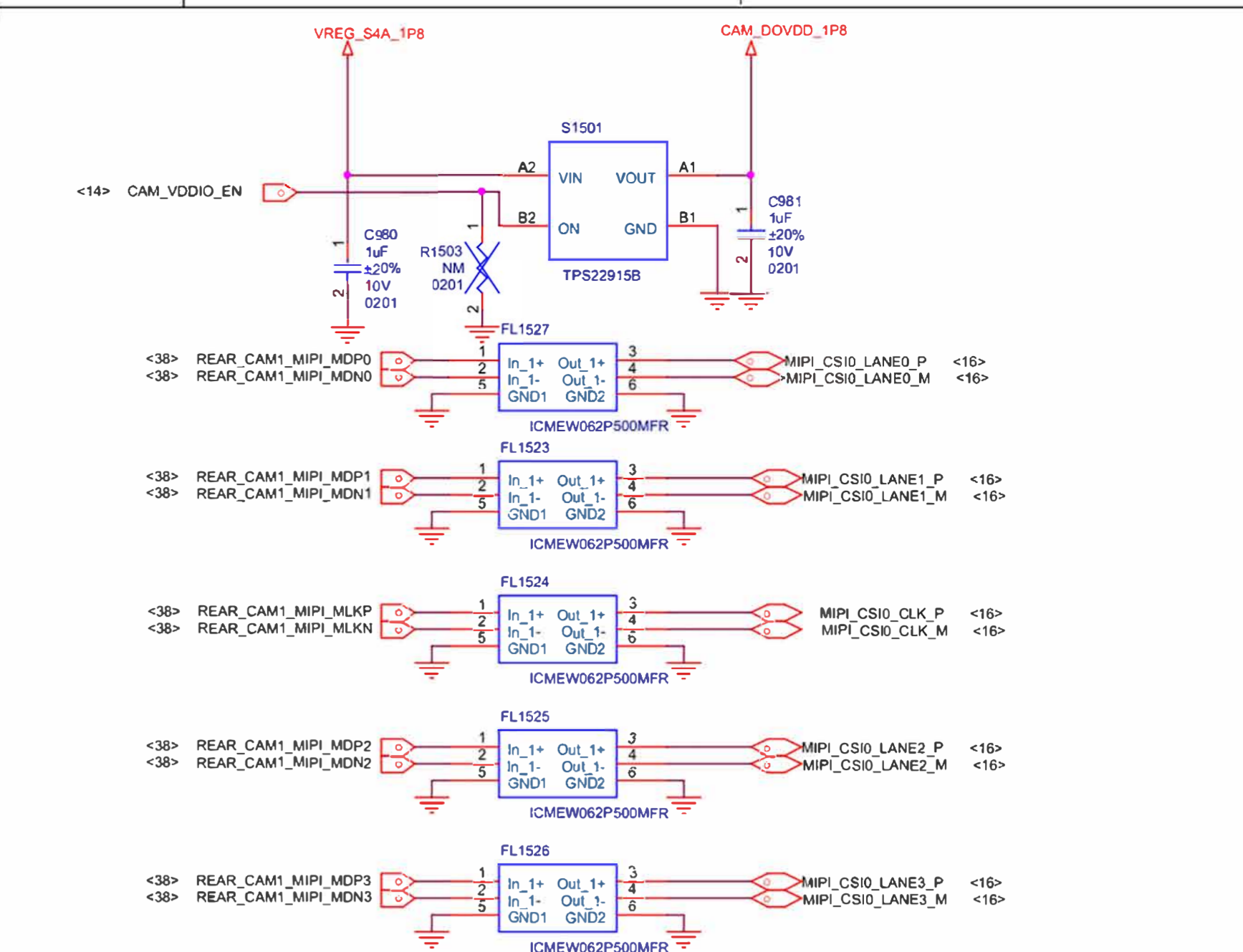
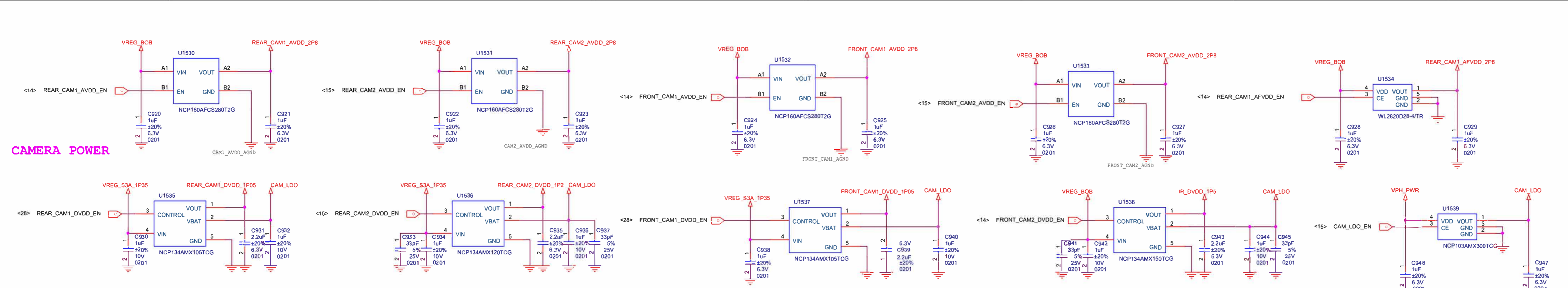

### REAR CAMERA 12M-CS10

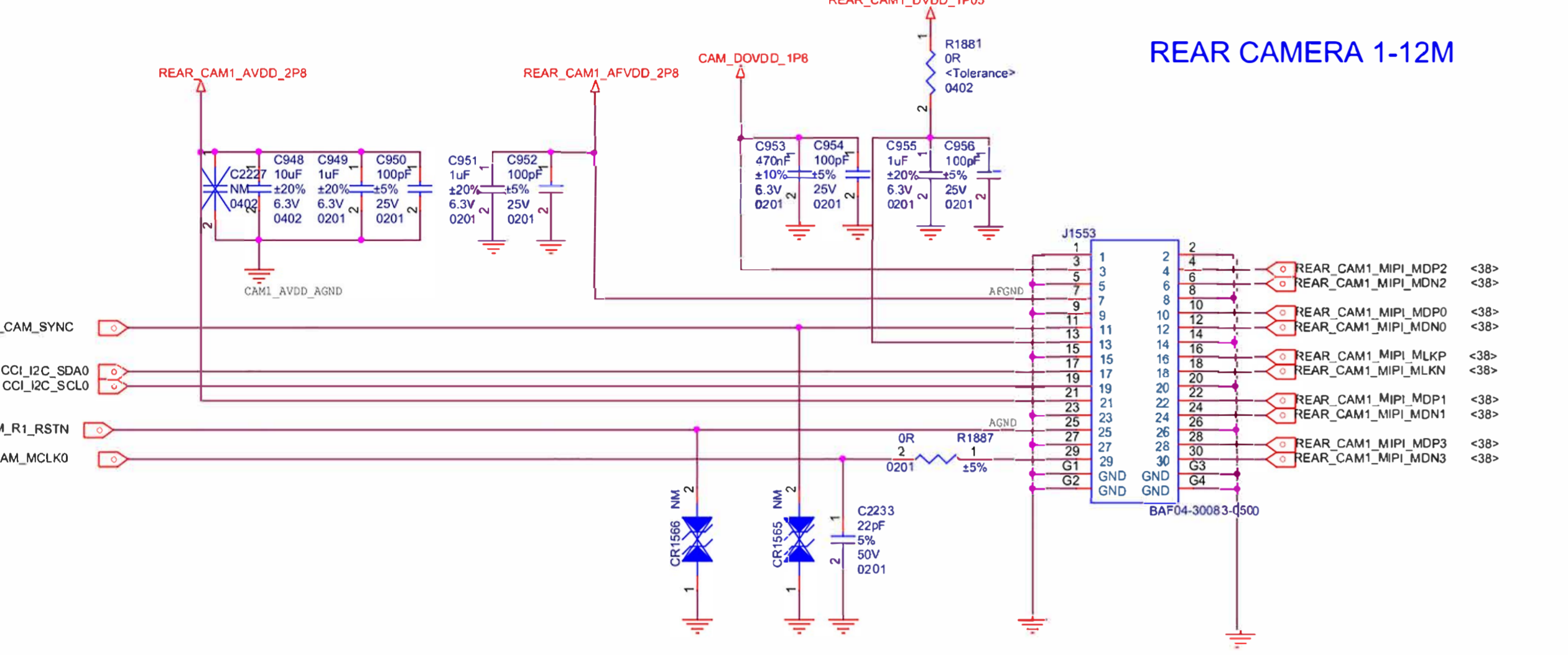

### REAR CAMERA 1-12M

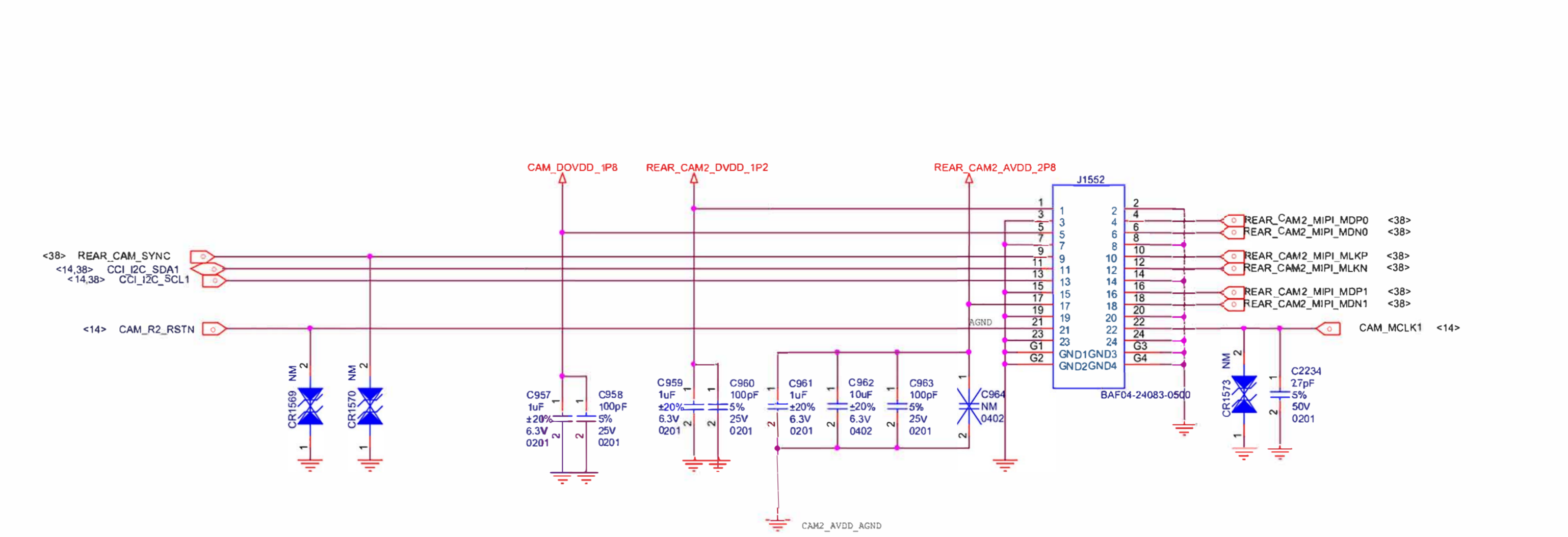

### REAR CAMERA 2-5M

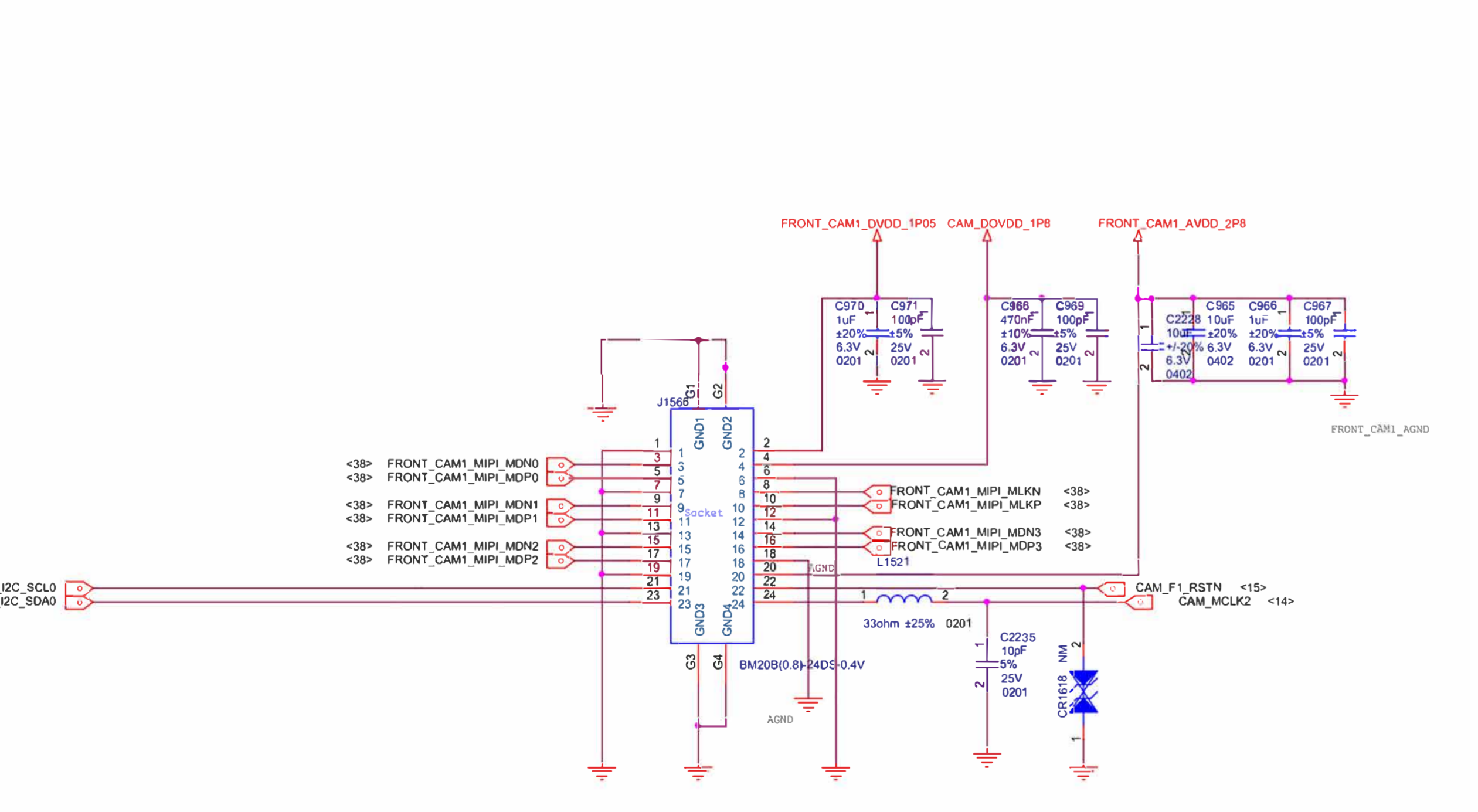

### FRONT CAMERA 1-20M

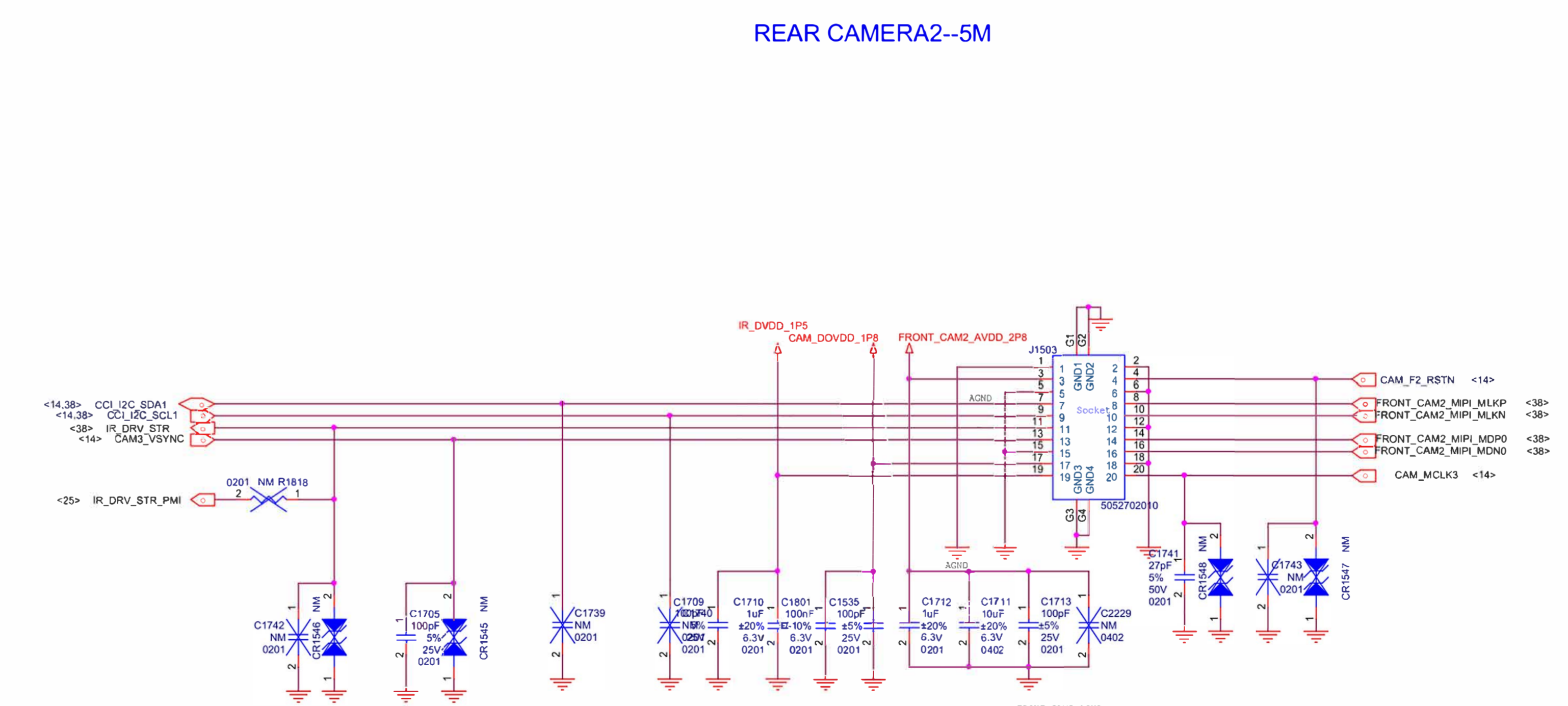

### FRONT IR CAMERA

### IR LED

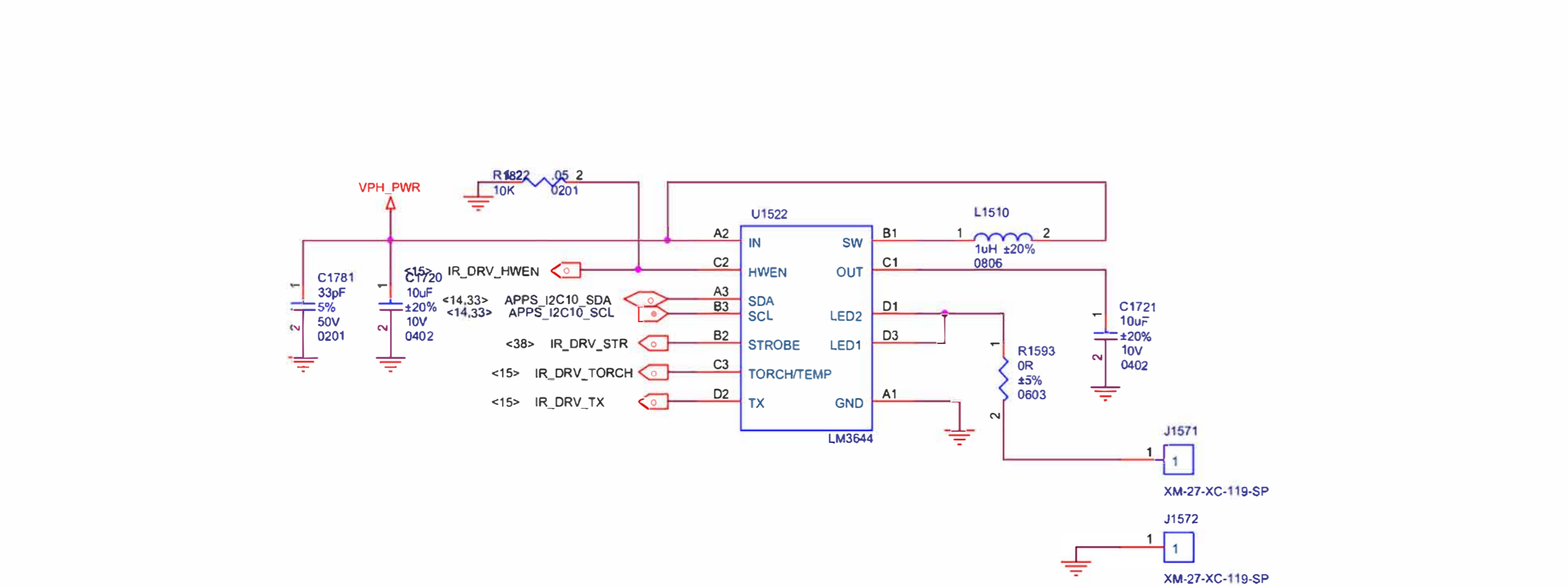

### FLASH LED

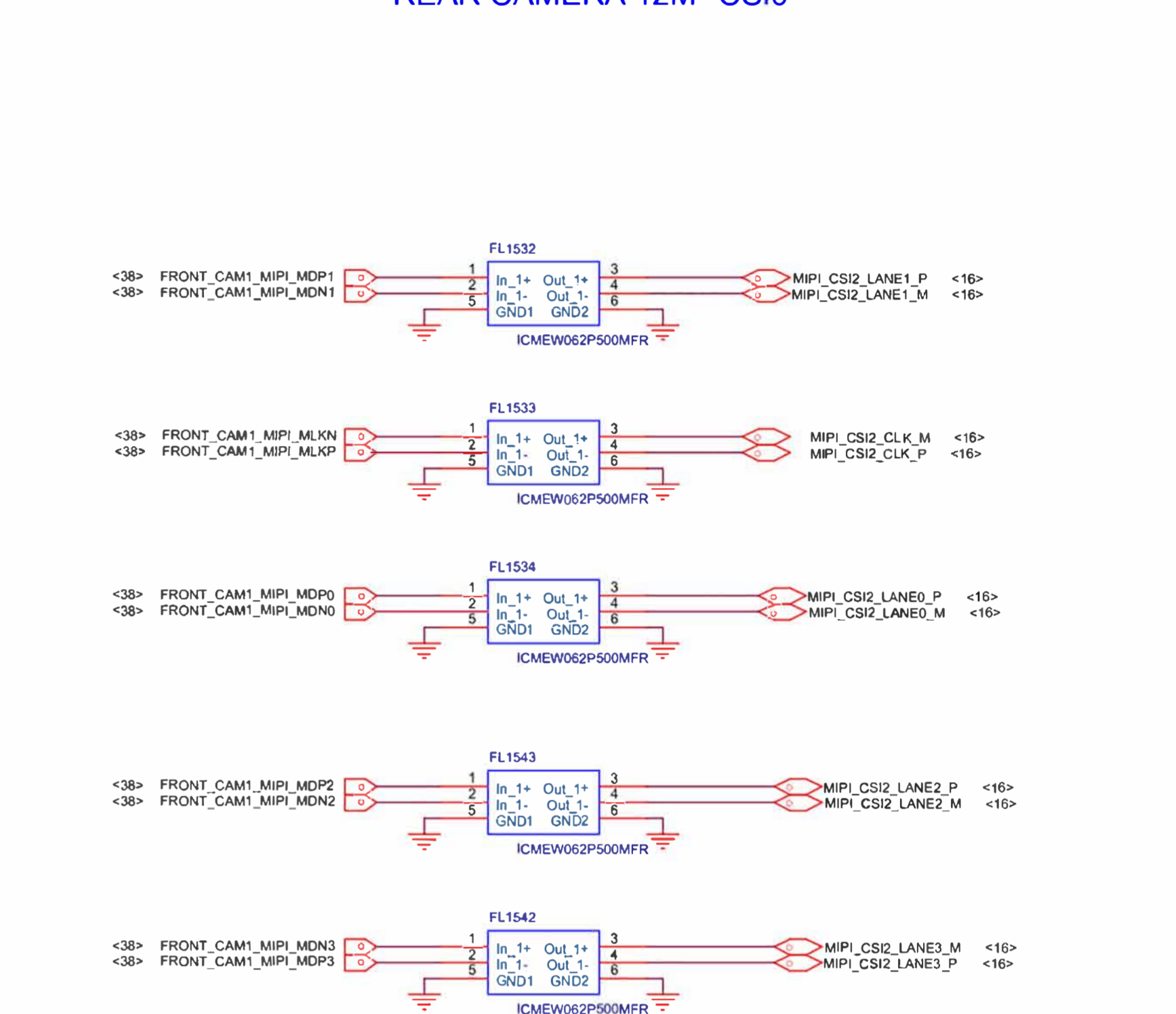
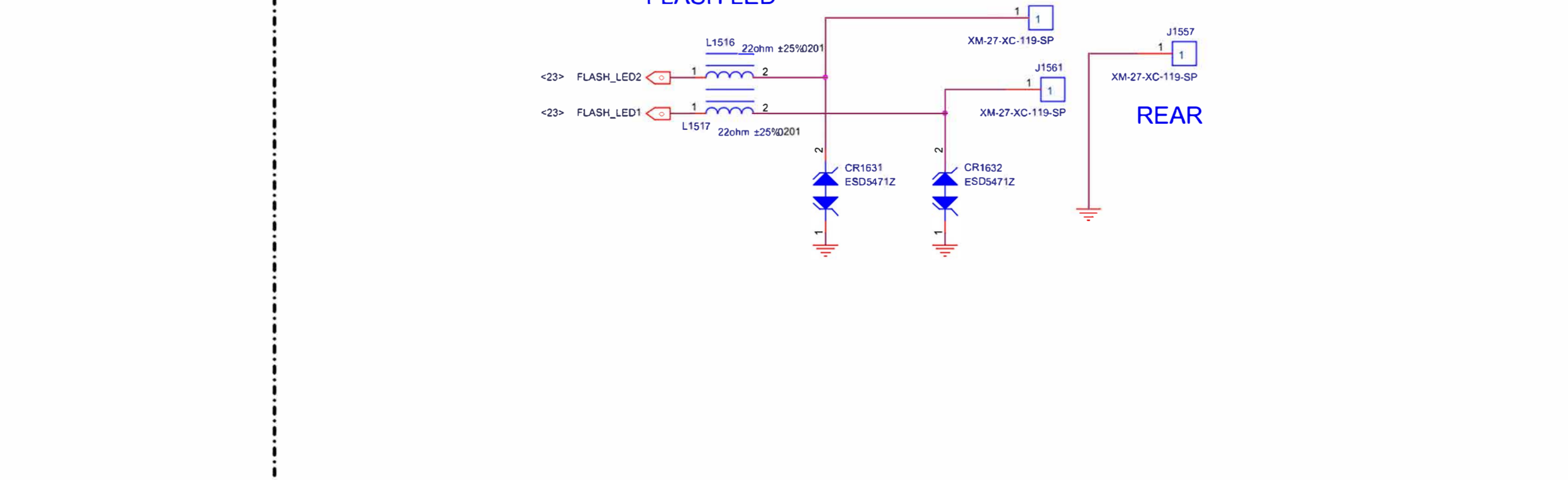

### FRONT CAMERA 20M-CS12

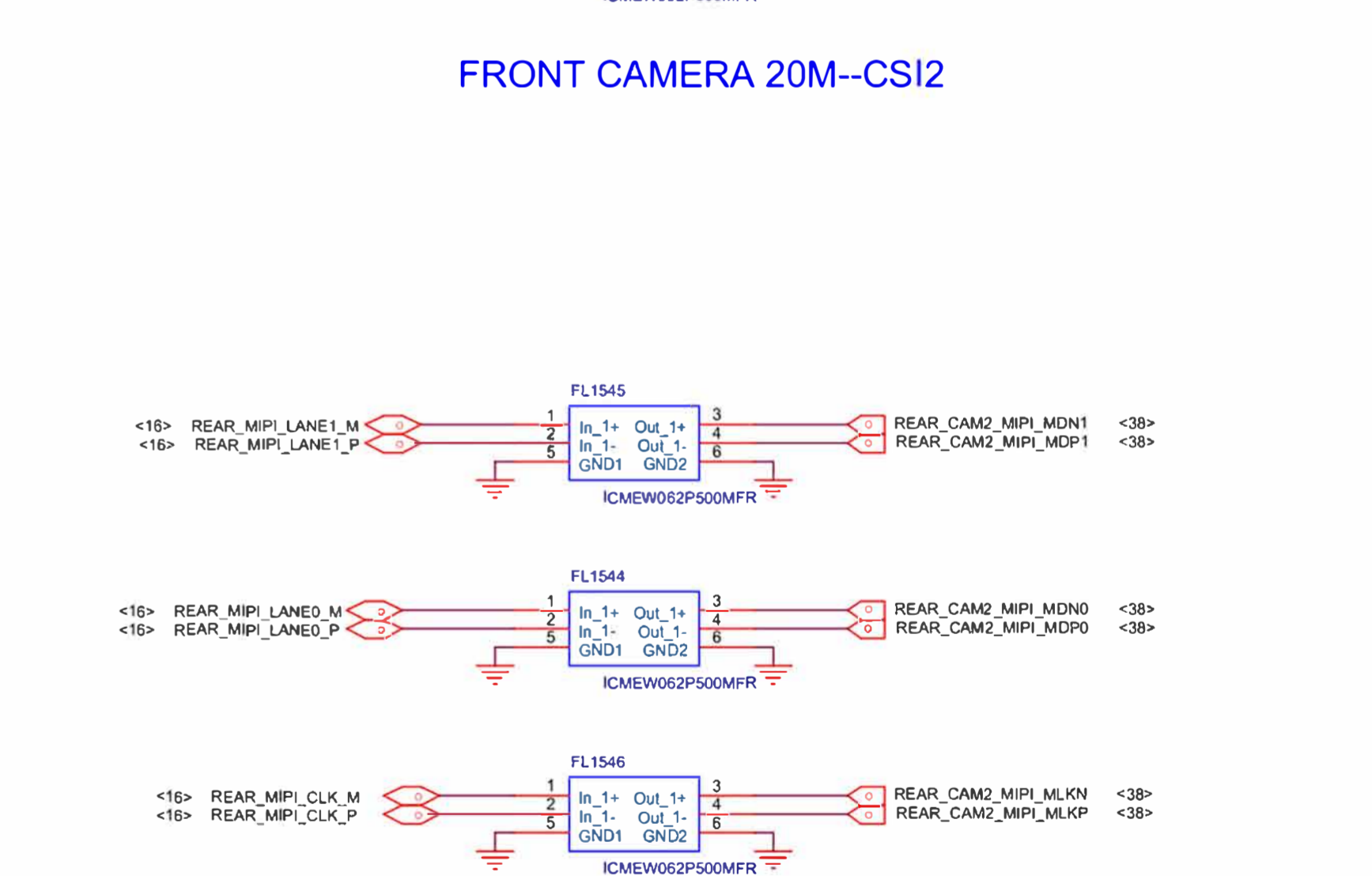

### REAR CAMERA 5M-CS11

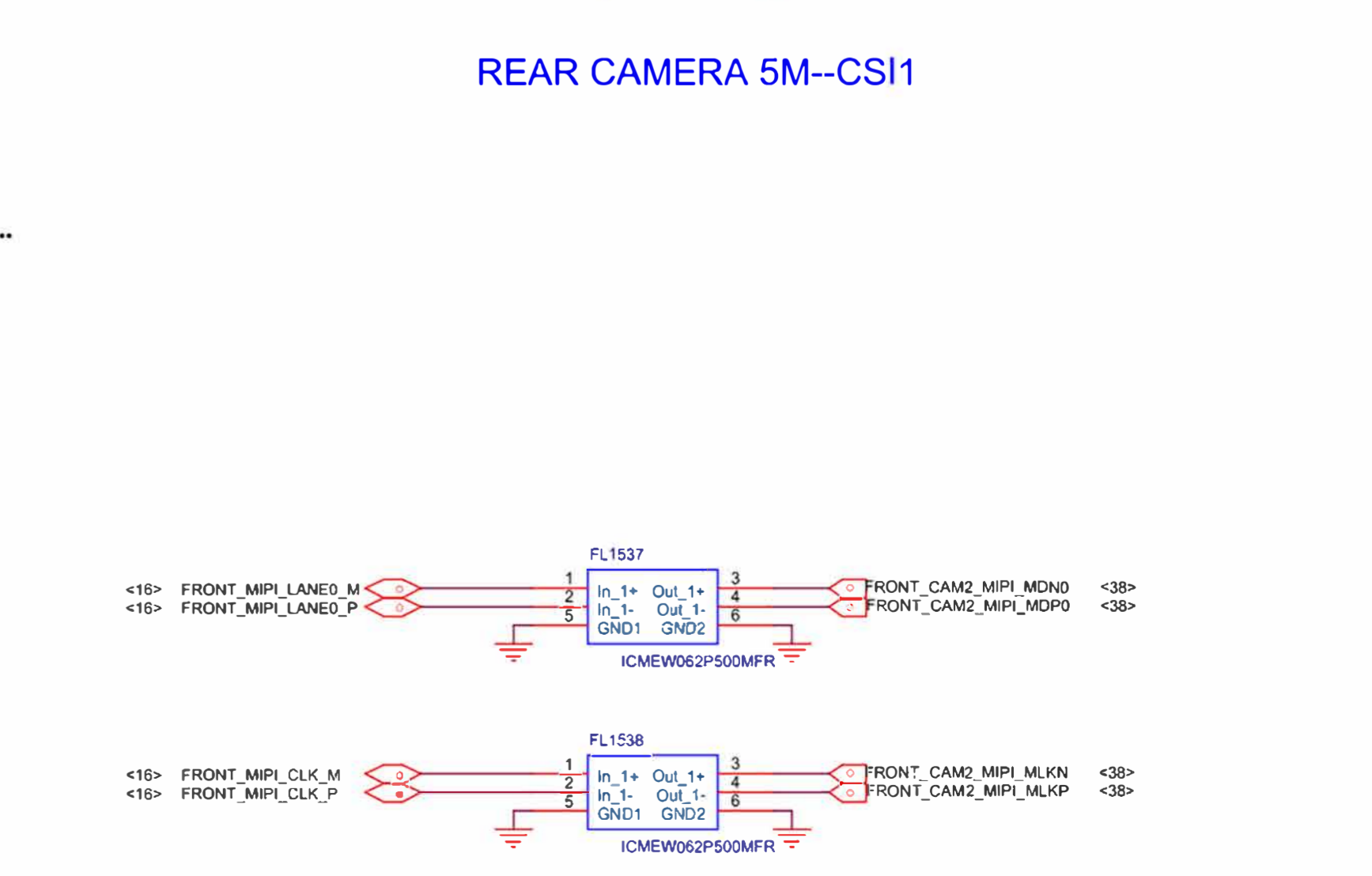

### FRONT IR CAMERA-CS11

# P-sensor

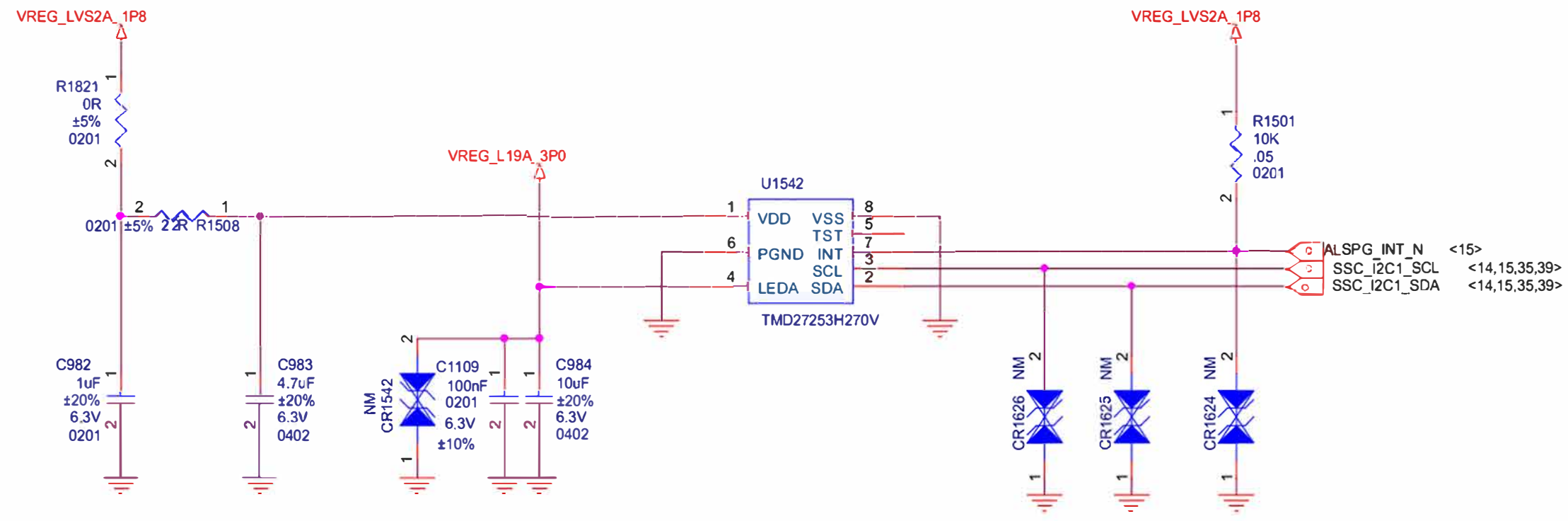

# G+G

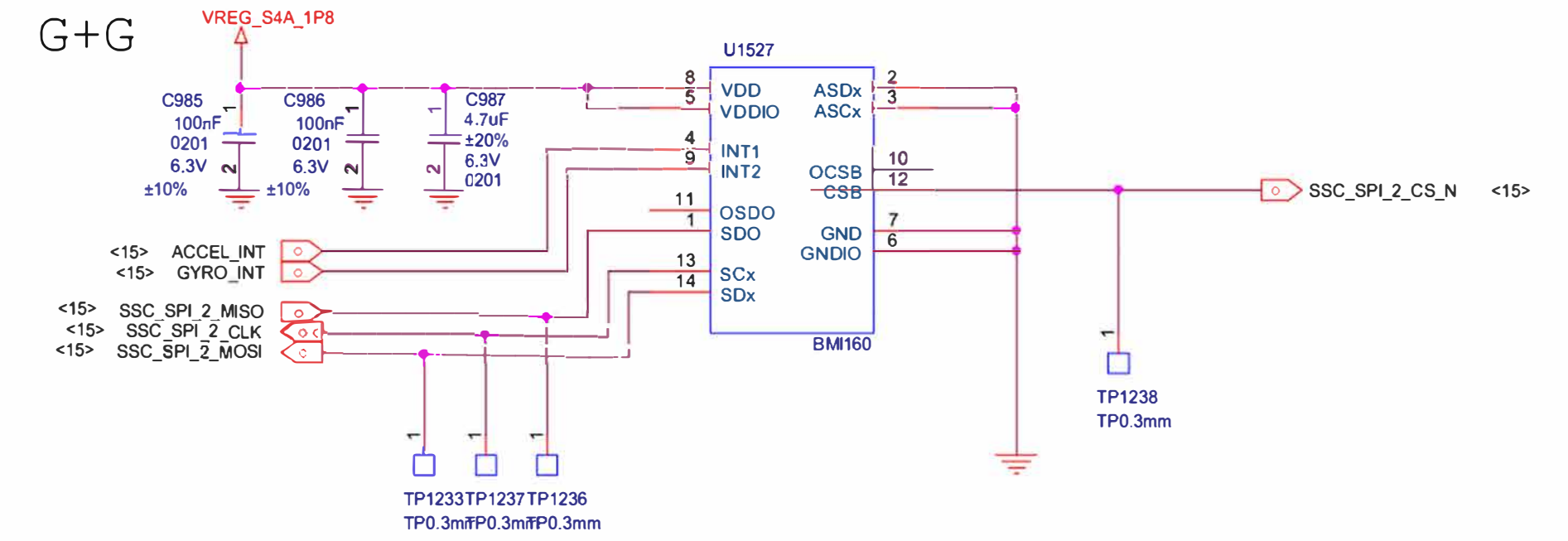

# COMPASS

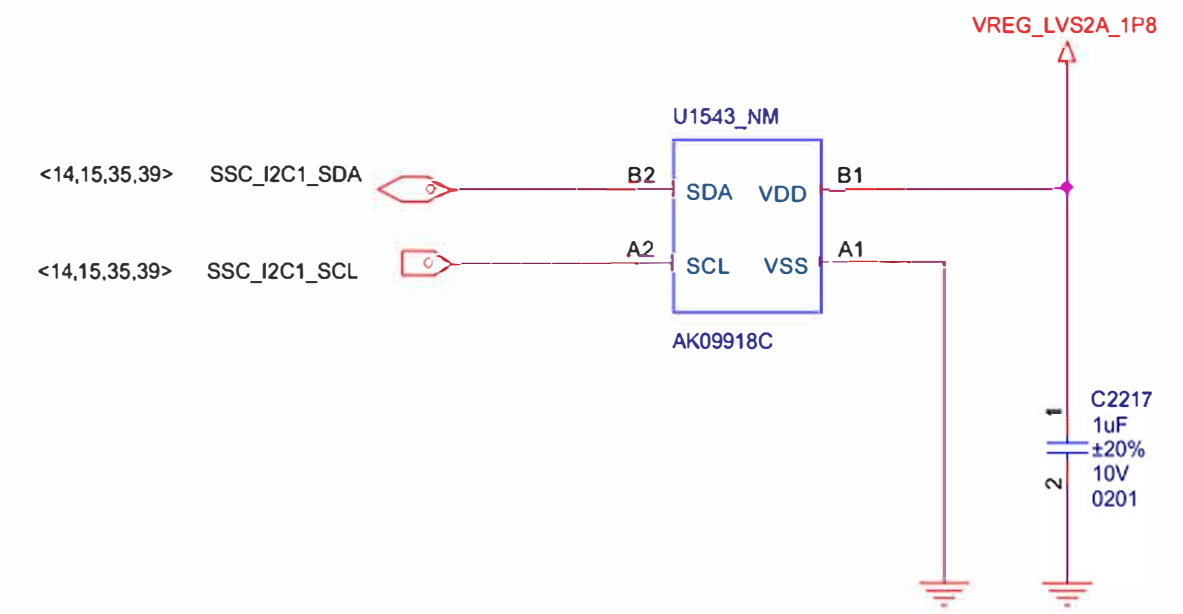

# FINGERPRINT

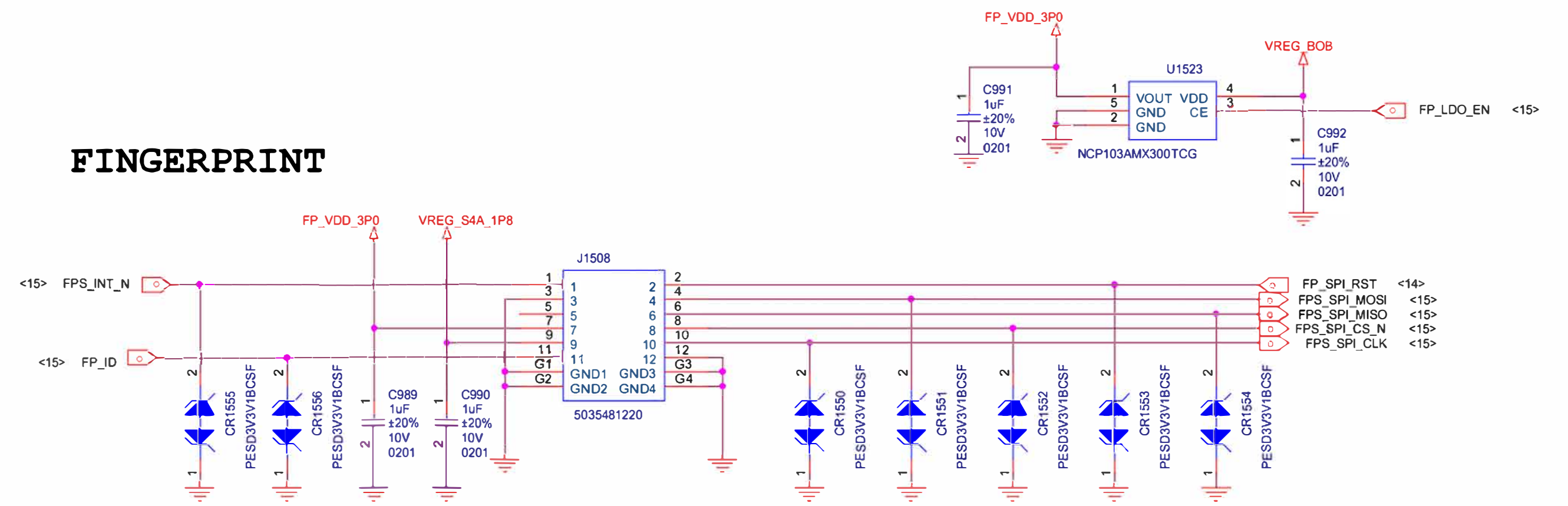

# COMPASS

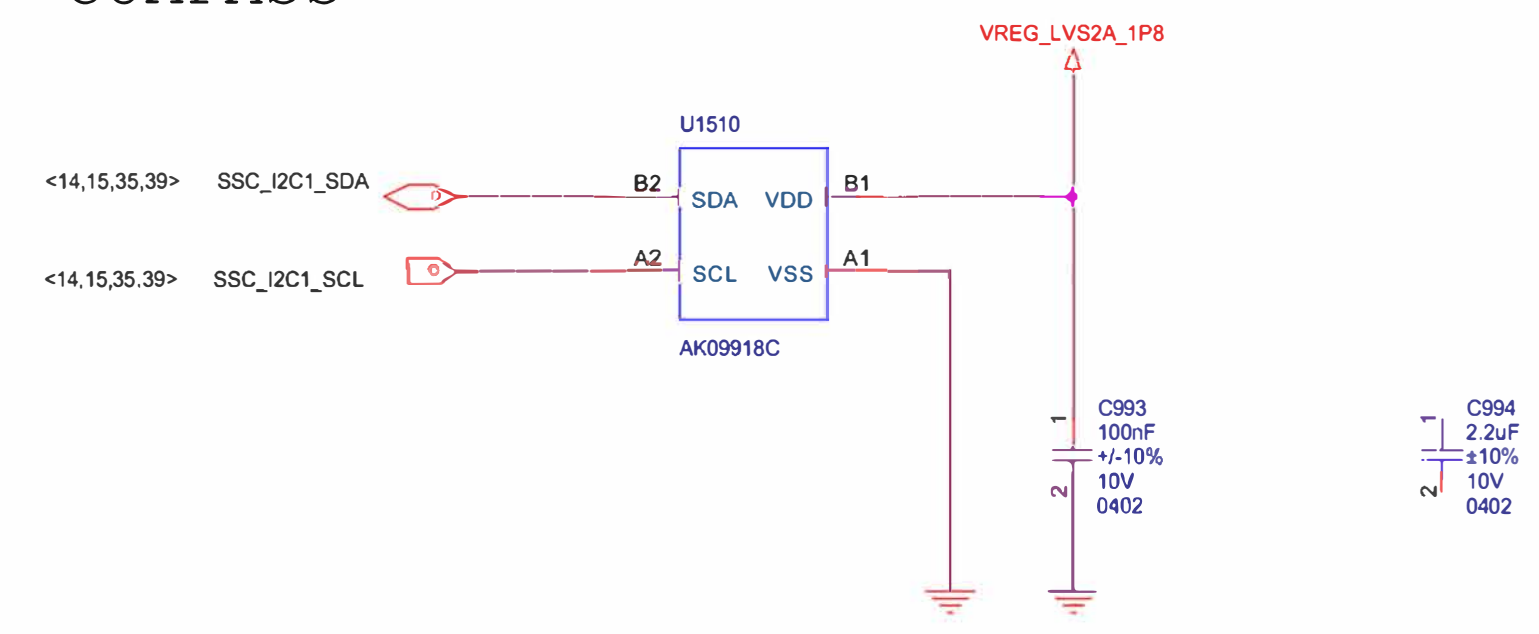

# HALL

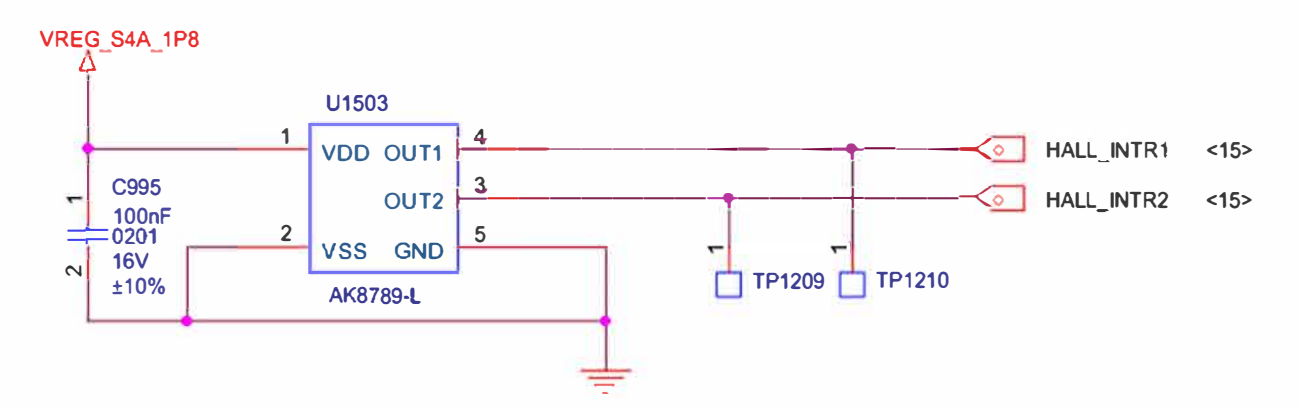

Title		
E10		
Size	Document Number	Rev
A2	SENSOR	P0
Date:	Sheet	39 of 40

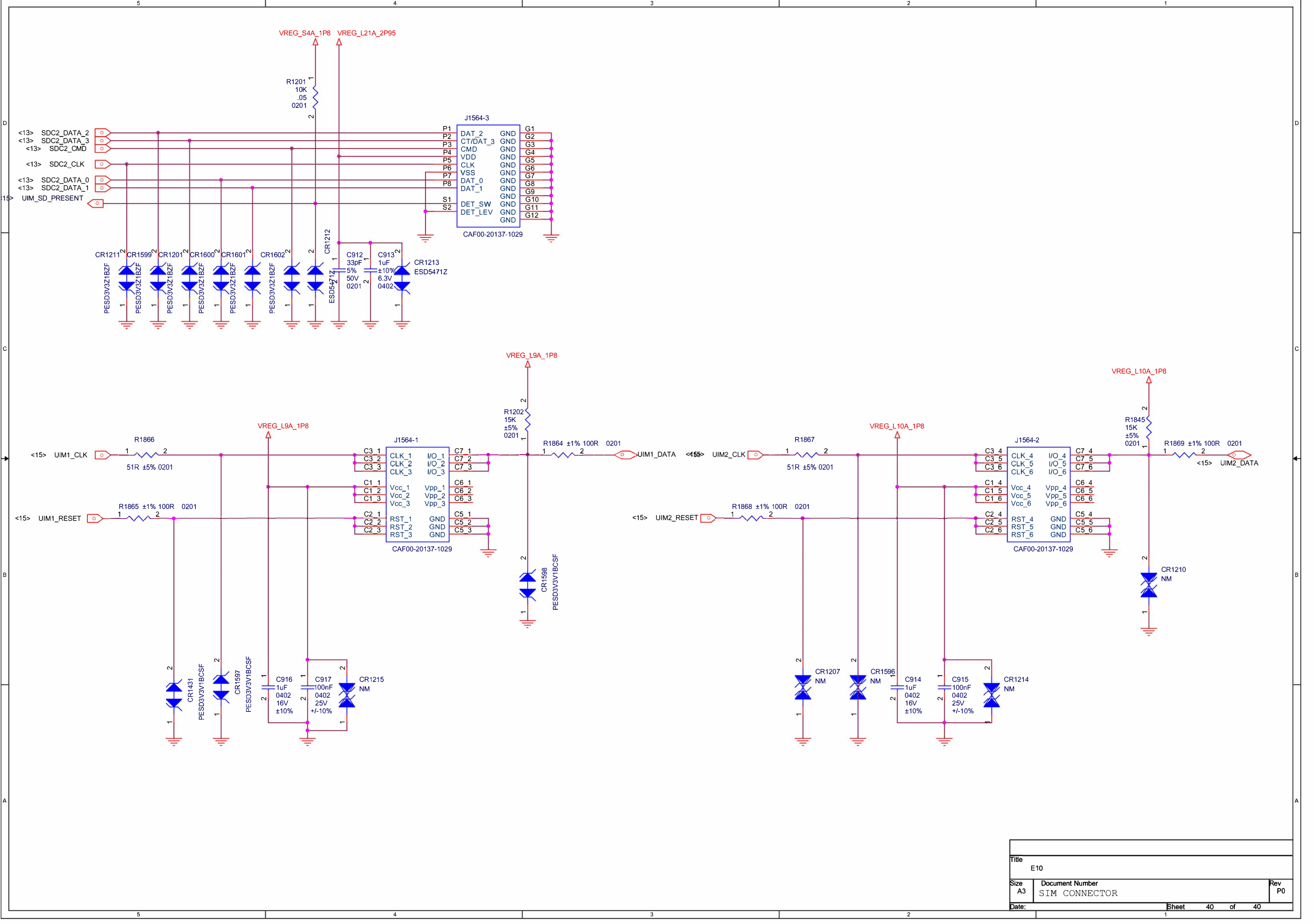

Title		
E10		
Size	Document Number	Rev
A3	SIM CONNECTOR	P0
Date:	Sheet	40 of 40



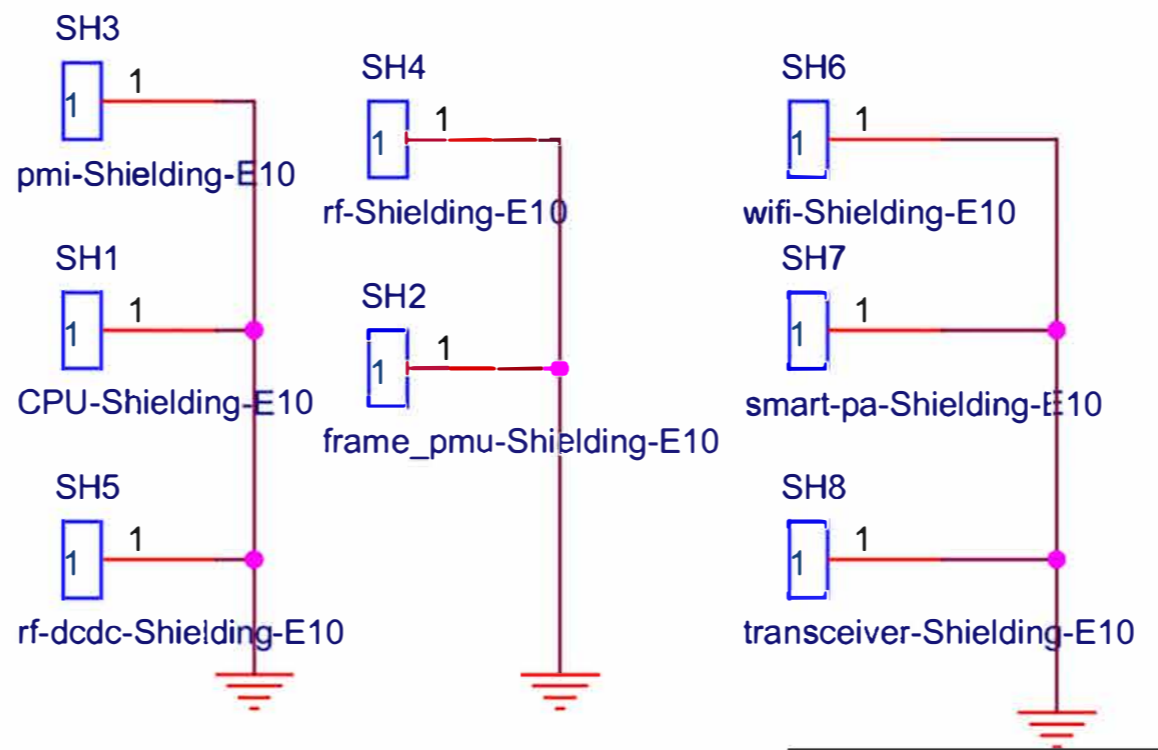
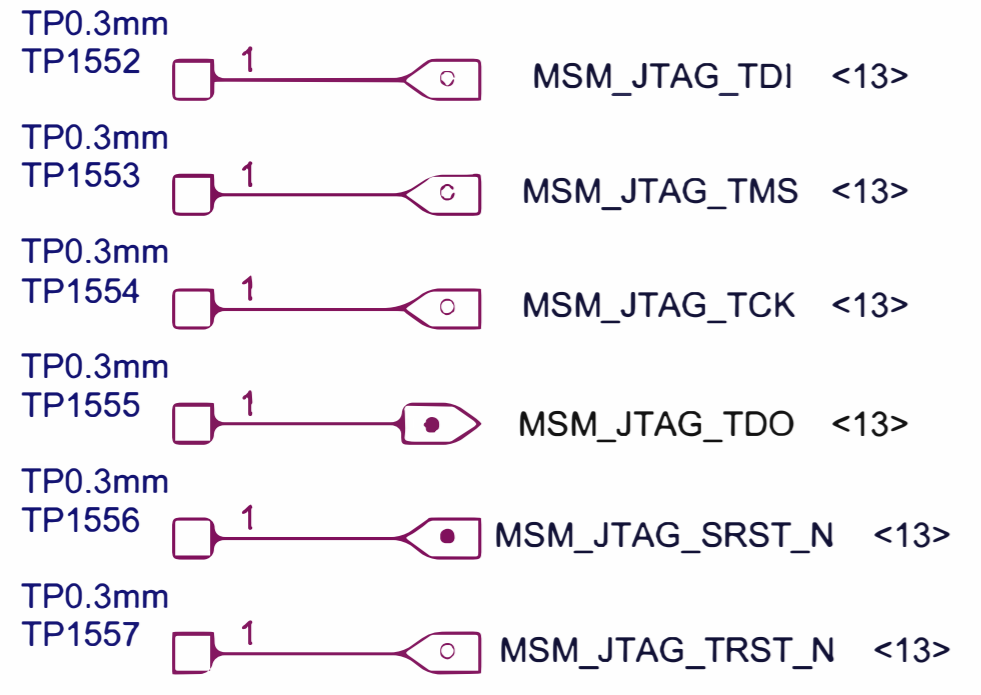
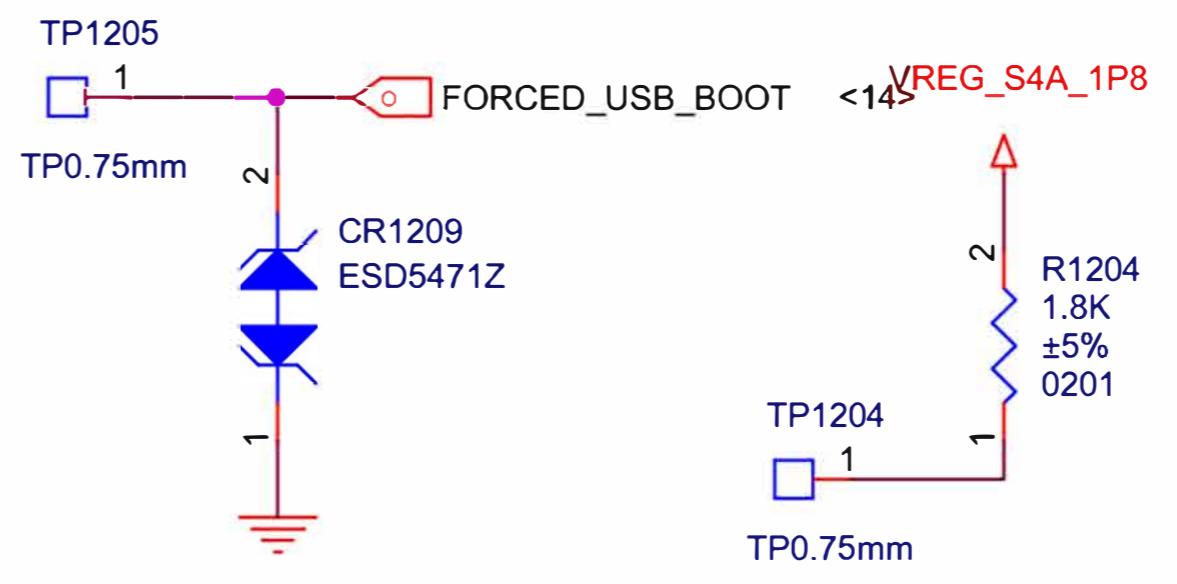
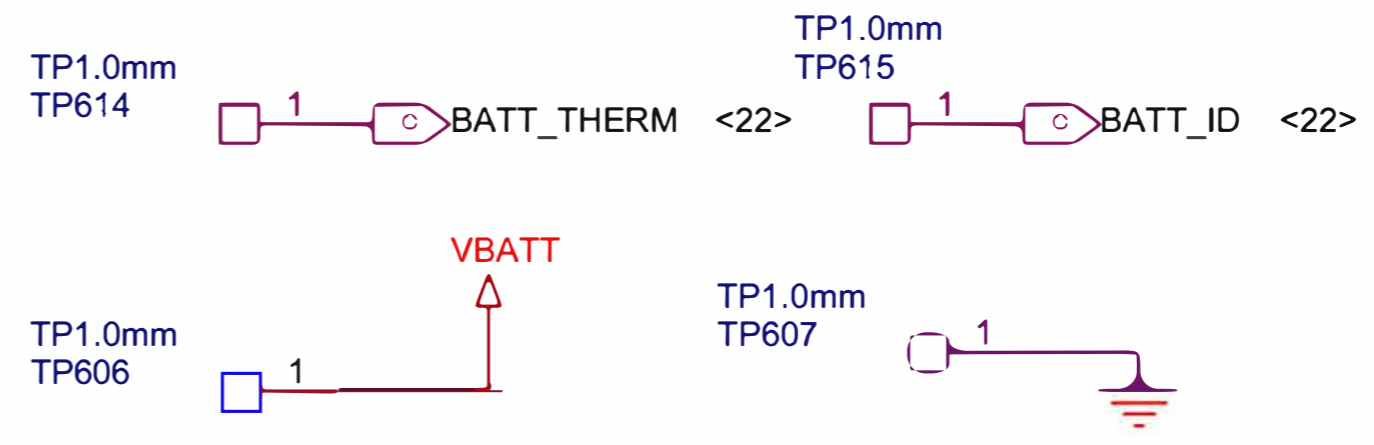
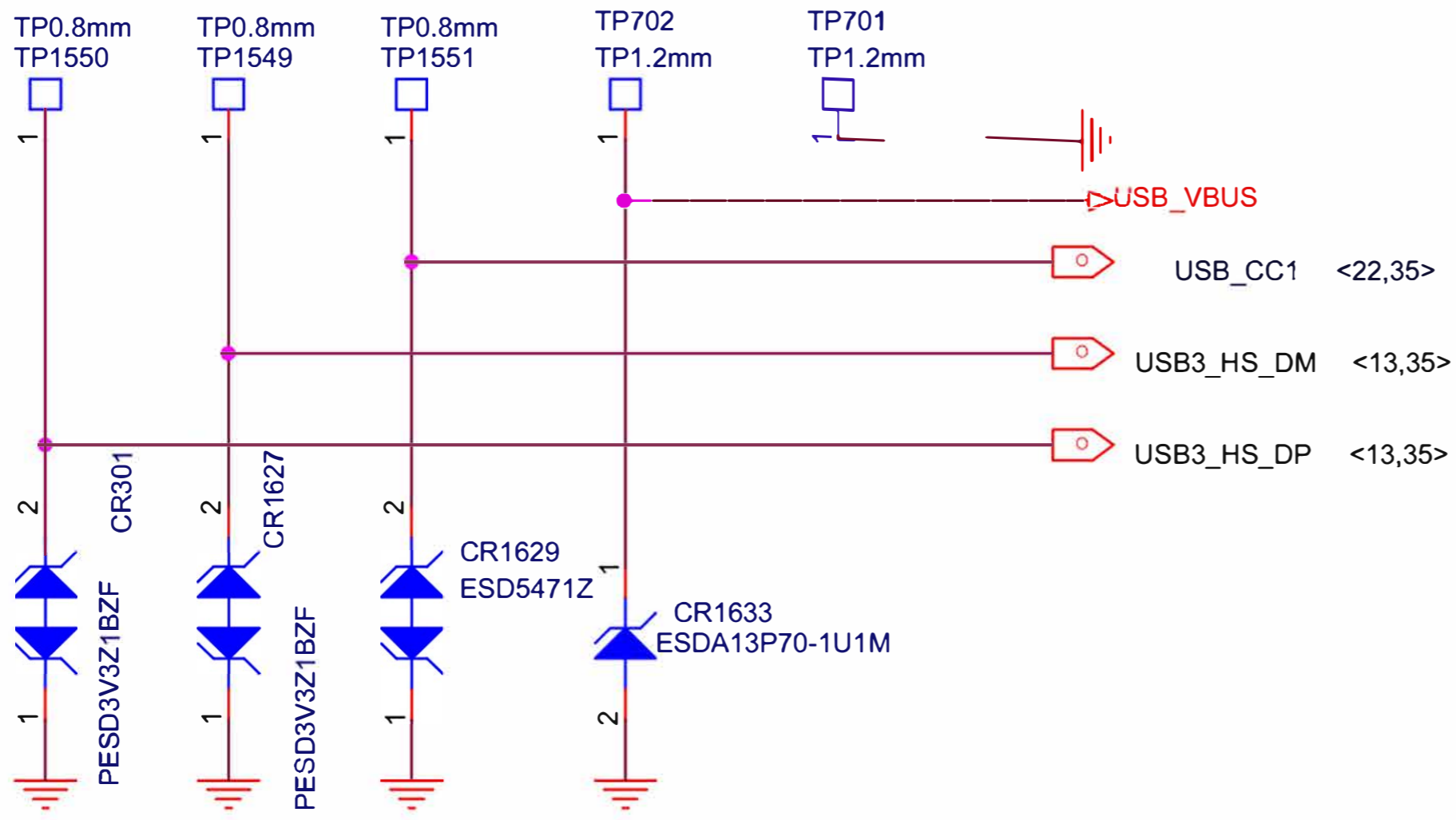

Title		
E10		
Size	Document Number	Rev
A	<Doc>	<RevCode>
Date:	Friday, May 11, 2018	Sheet 41 of 41



J503

J506

J1563

J1565

J1566

J1567

J1568

J1569

J1570

J1571

J1572

J702

J703

K4

J1566

J1567

J1568

J1569

J1570

J1571

J1572

J1573

J1574

J1575

J117\_NM

J118

J113

J1103

J1566

J1567

J1568

J1569

J1570

J1571

J1572

J1573

J1574

J1575

J1576

J1577

J1578

J1579

J1580

J1581

J1582

J1583

J1584

J1585

J117

J118

J113

J1103

J1566

J1567

J1568

J1569

J1570

J1571

J1572

J1573

J1574

J1575

J1576

J1577

J1578

J1579

J1580

J1581

J1582

J1583

J1584

J1585

J117

J118

J113

J1103

J1566

J1567

J1568

J1569

J1570

J1571

J1572

J1573

J1574

J1575

J1576

J1577

J1578

J1579

J1580

J1581

J1582

J1583

J1584

J1585

J117

J118

J113

J1103

J1566

J1567

J1568

J1569

J1570

J1571

J1572

J1573

J1574

J1575

J1576

J1577

J1578

J1579

J1580

J1581

J1582

J1583

J1584

J1585

J117

J118

J113

J1103

J1566

J1567

J1568

J1569

J1570

J1571

J1572

J1573

J1574

J1575

J1576

J1577

J1578

J1579

J1580

J1581

J1582

J1583

J1584

J1585

J117

J118

J113

J1103

J1566

J1567

J1568

J1569

J1570

J1571

J1572

J1573

J1574

J1575

J1576

J1577

J1578

J1579

J1580

J1581

J1582

J1583

J1584

J1585

