

Xiaomi Redmi Y3 Schematic Diagram



Xiaomi
Smartphone

Schematic

Diagram



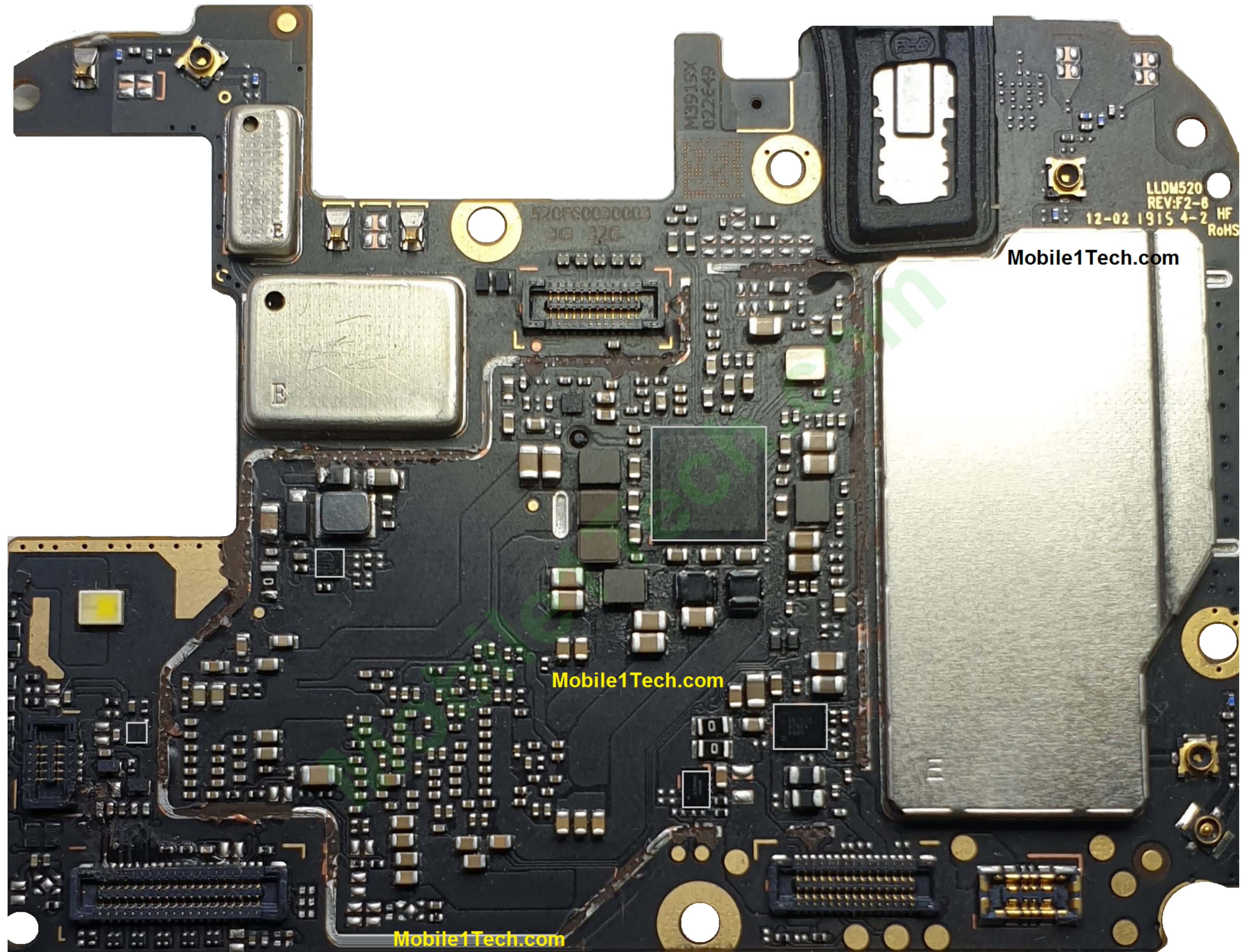

Xiaomi Redmi Y3 /PCB:LLDM520

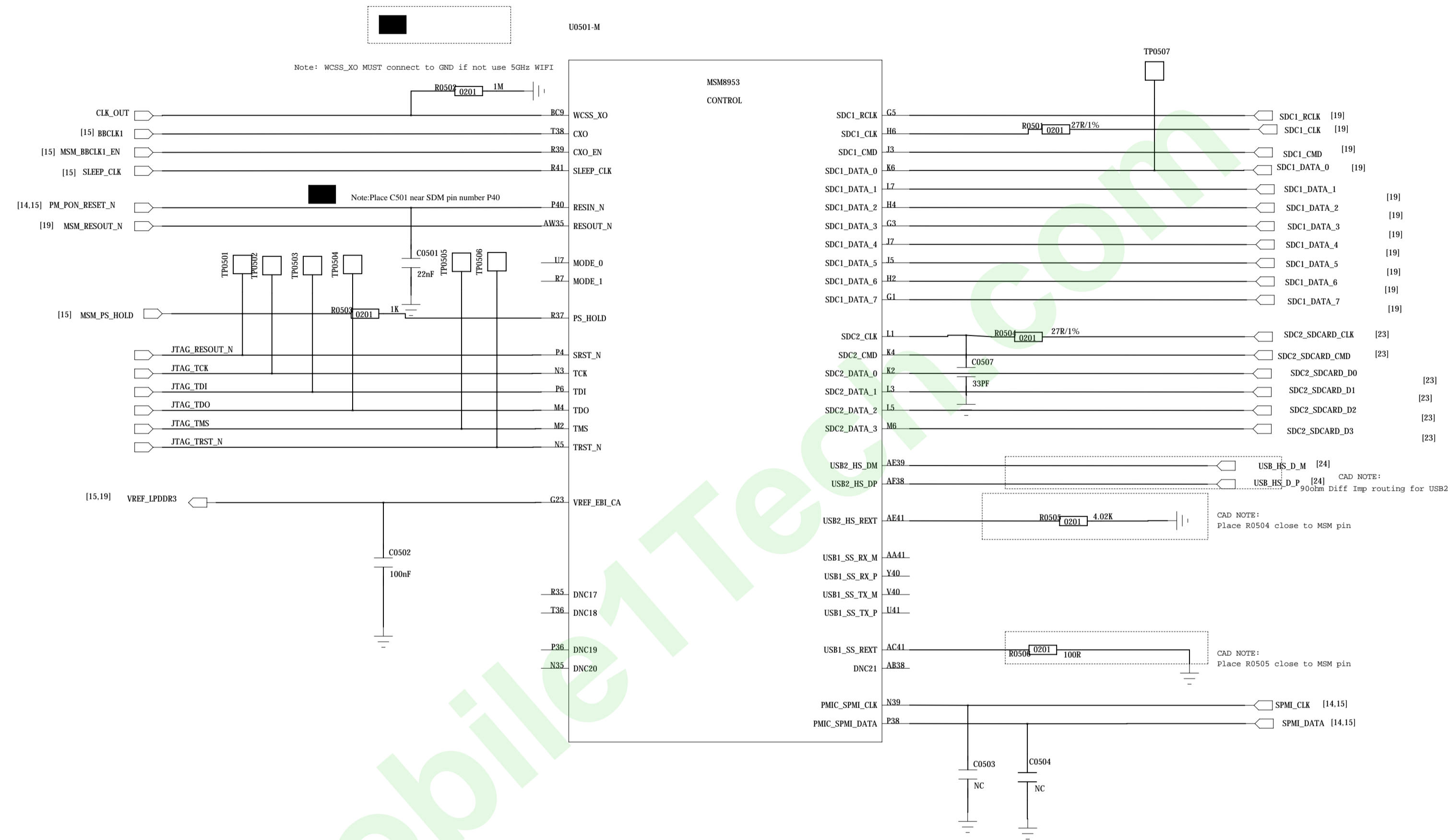

U0501-B

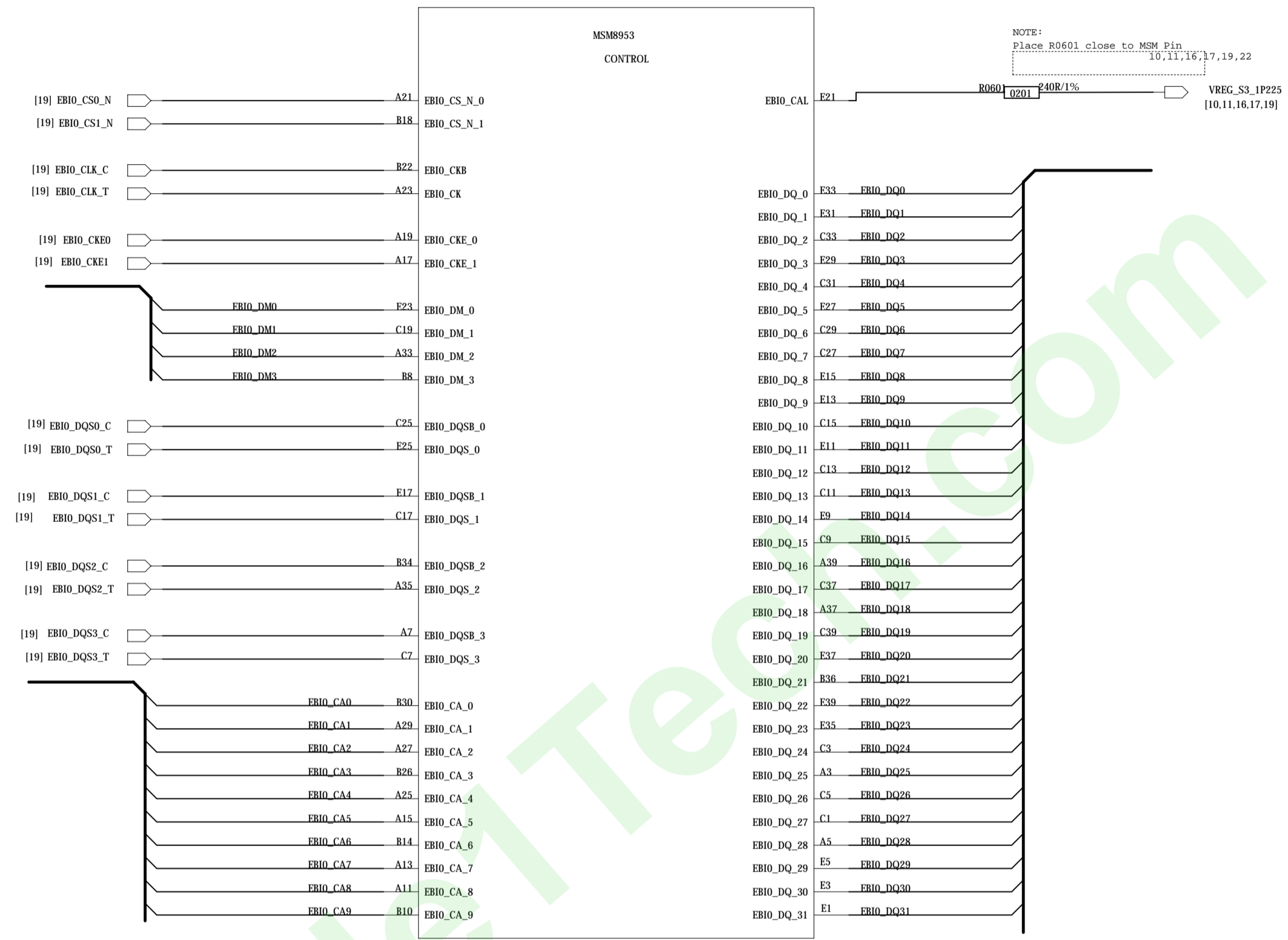

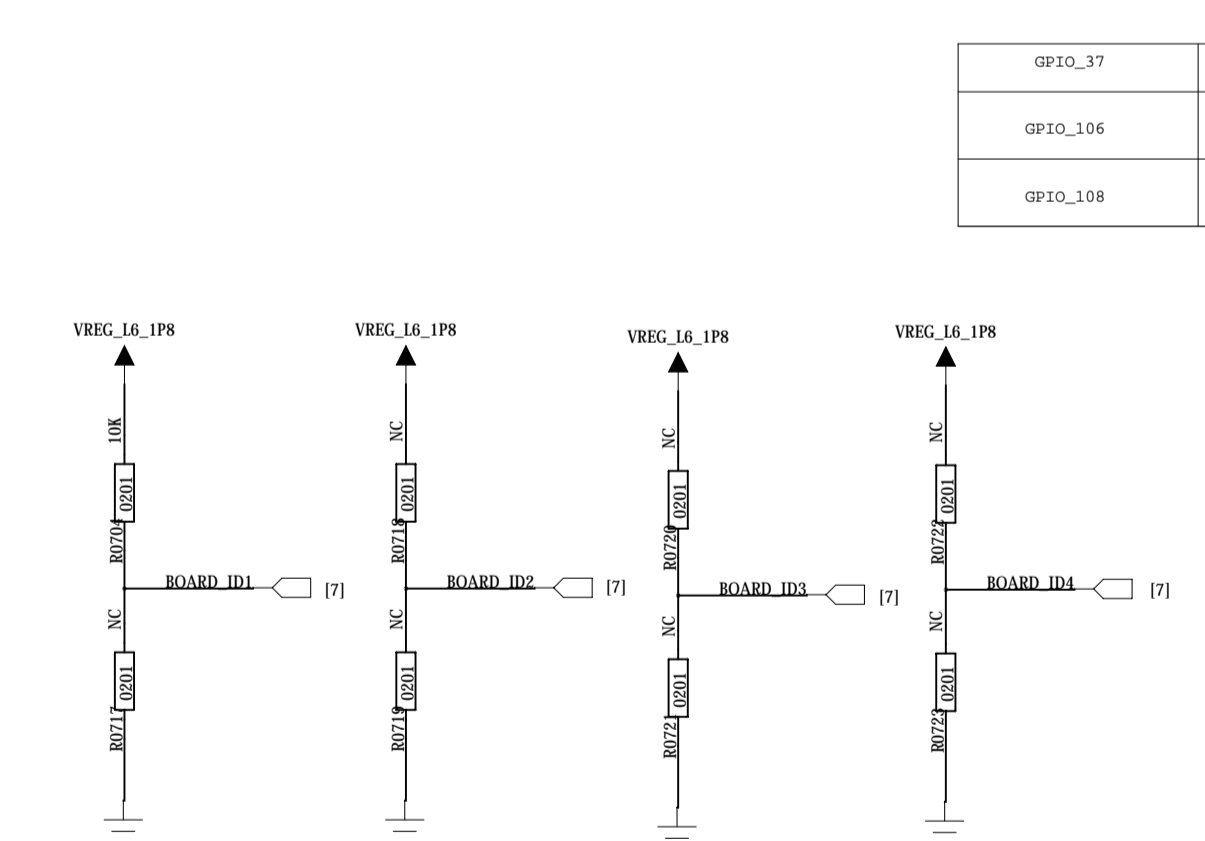
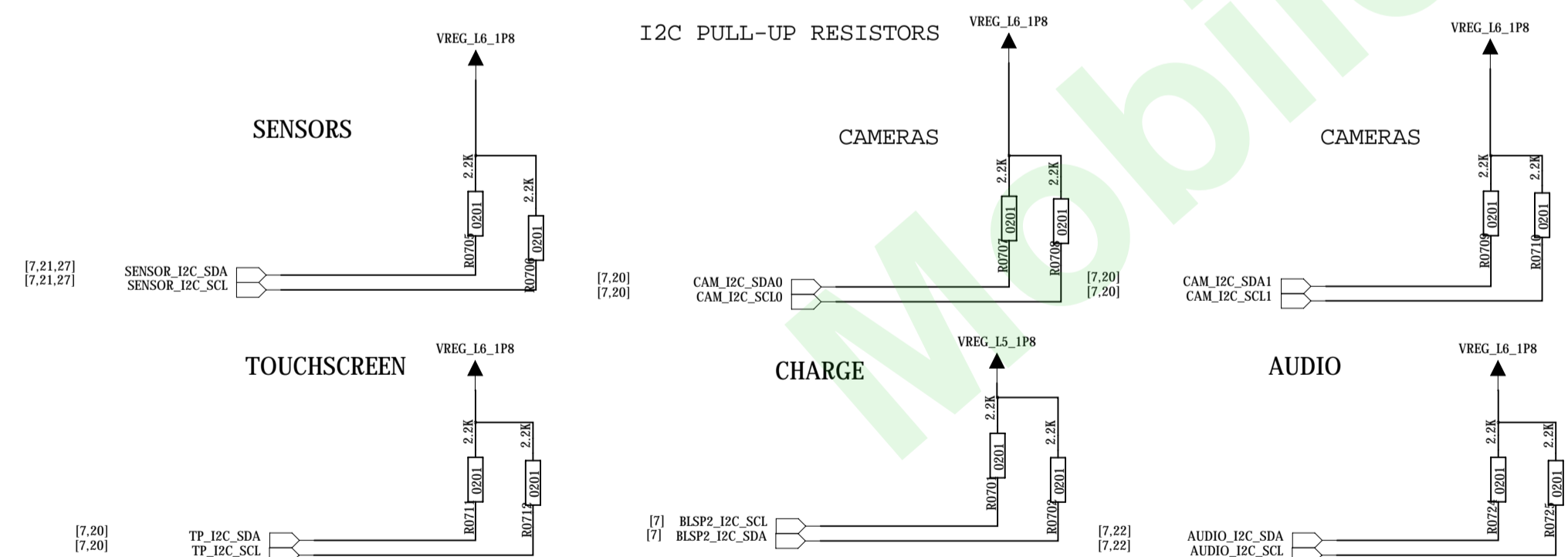
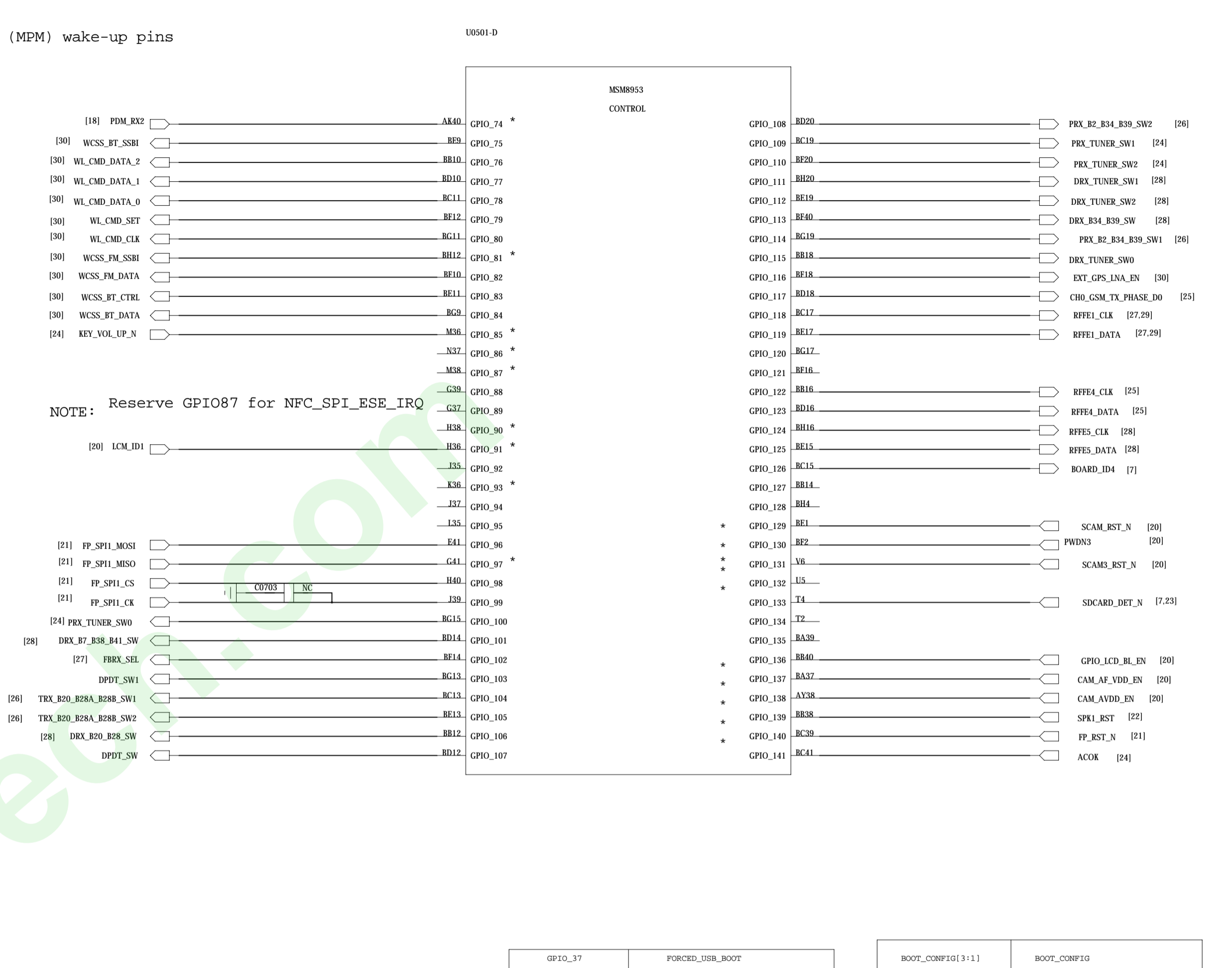
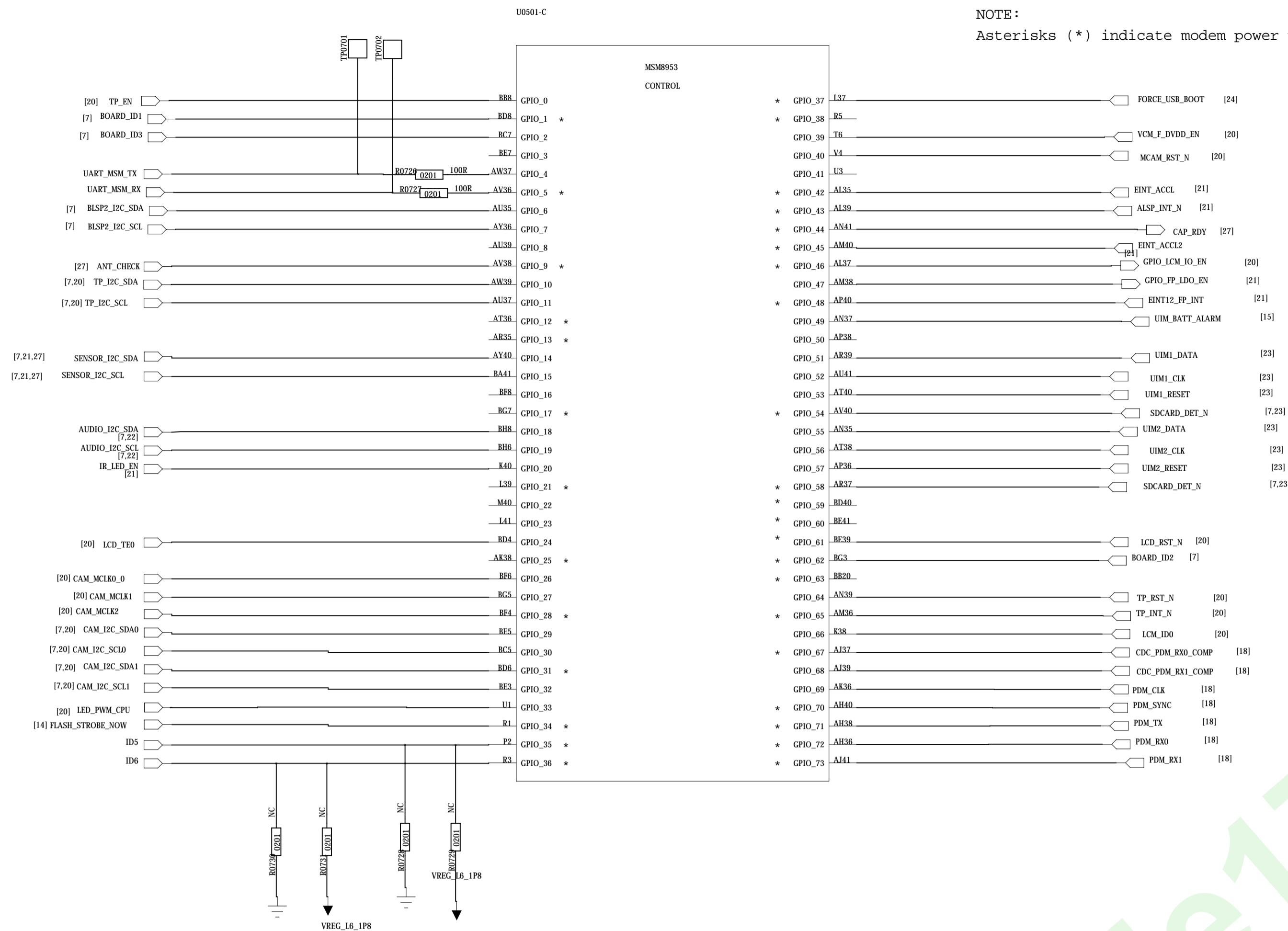

GPIO_37	FORCED_USB_BOOT
GPIO_106	MDMG_DISABLE
GPIO_108	APPS_BOOT_FROM_ROM

BOOT_CONFIG[3:1]	BOOT_CONFIG
0b000	SDC1 -> SDC2 -> USB2.0
0b001	SDC2 -> SDC1 -> USB2.0
0b010	SDC1 -> USB2.0
0b011	USB2.0

Default Boot Config (0b000) is SDC1(eMMC)

NOTE:
Ensure SW sets these GPIOs (Sensor, CTP and Camera I2C bus) to input pull down when the peripherals are powered off to eliminate leakage.

U0501-E

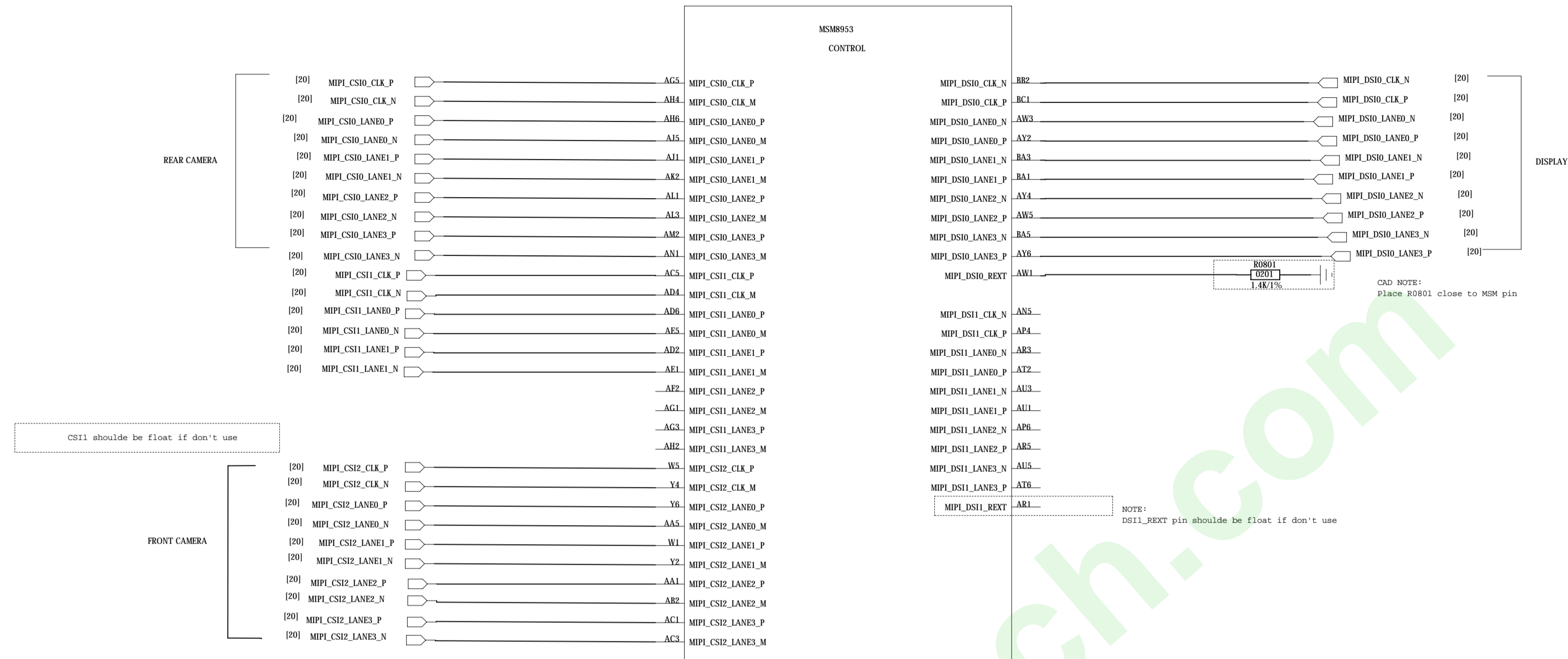

CSI Pin Name	CSI DPHY 4-lane	CSI DPHY 2+1 Mode	CSI CPHY 3Phase Mode
CSI0_3PHASE_PIN0	CSI0_CLKP	CSI0_2LANE_CLKP	NC
CSI0_3PHASE_PIN1	CSI0_CLKN	CSI0_2LANE_CLKN	CSI0_TRI0_A
CSI0_3PHASE_PIN2	CSI0_DP0	CSI0_2LANE_DP0	CSI0_TRI0_B
CSI0_3PHASE_PIN3	CSI0_DN0	CSI0_2LANE_DN0	CSI0_TRI0_C
CSI0_3PHASE_PIN4	CSI0_DP1	CSI0_2LANE_DP1	CSI0_TRI1_A
CSI0_3PHASE_PIN5	CSI0_DN1	CSI0_2LANE_DN1	CSI0_TRI1_B
CSI0_3PHASE_PIN6	CSI0_DP2	CSI0_1LANE_DP0	CSI0_TRI1_C
CSI0_3PHASE_PIN7	CSI0_DN2	CSI0_1LANE_DN0	CSI0_TRI2_A
CSI0_3PHASE_PIN8	CSI0_DP3	CSI0_1LANE_CLKP	CSI0_TRI2_B
CSI0_3PHASE_PIN9	CSI0_DN3	CSI0_2LANE_CLKN	CSI0_TRI2_C
CSI1_3PHASE_PIN1	CSI1_CLKN	CSI1_2LANE_CLKN	CSI1_TRI0_A
CSI1_3PHASE_PIN2	CSI1_DP0	CSI1_2LANE_DP0	CSI1_TRI0_B
CSI1_3PHASE_PIN3	CSI1_DN0	CSI1_2LANE_DN0	CSI1_TRI0_C
CSI1_3PHASE_PIN4	CSI1_DP1	CSI1_2LANE_DP1	CSI1_TRI1_A
CSI1_3PHASE_PIN5	CSI1_DN1	CSI1_2LANE_DN1	CSI1_TRI1_B
CSI1_3PHASE_PIN6	CSI1_DP2	CSI1_1LANE_DP0	CSI1_TRI1_C
CSI1_3PHASE_PIN7	CSI1_DN2	CSI1_1LANE_DN0	CSI1_TRI2_A
CSI1_3PHASE_PIN8	CSI1_DP3	CSI1_1LANE_CLKP	CSI1_TRI2_B
CSI1_3PHASE_PIN9	CSI1_DN3	CSI1_2LANE_CLKN	CSI1_TRI2_C
CSI2_3PHASE_PIN1	CSI2_CLKN	CSI2_2LANE_CLKN	CSI2_TRI0_A
CSI2_3PHASE_PIN2	CSI2_DP0	CSI2_2LANE_DP0	CSI2_TRI0_B
CSI2_3PHASE_PIN3	CSI2_DN0	CSI2_2LANE_DN0	CSI2_TRI0_C
CSI2_3PHASE_PIN4	CSI2_DP1	CSI2_2LANE_DP1	CSI2_TRI1_A
CSI2_3PHASE_PIN5	CSI2_DN1	CSI2_2LANE_DN1	CSI2_TRI1_B
CSI2_3PHASE_PIN6	CSI2_DP2	CSI2_1LANE_DP0	CSI2_TRI1_C
CSI2_3PHASE_PIN7	CSI2_DN2	CSI2_1LANE_DN0	CSI2_TRI2_A
CSI2_3PHASE_PIN8	CSI2_DP3	CSI2_1LANE_CLKP	CSI2_TRI2_B
CSI2_3PHASE_PIN9	CSI2_DN3	CSI2_1LANE_CLKN	CSI2_TRI2_C

NOT TO BE USED, COPIED, REPRODUCED IN WHOLE OR IN PART. NOR ITS CONTENTS REVEALED IN ANY MANNER TO OTHERS WITHOUT THE EXPRESS WRITTEN PERMISSION OF QUALCOMM.

MSM8953 MIPI

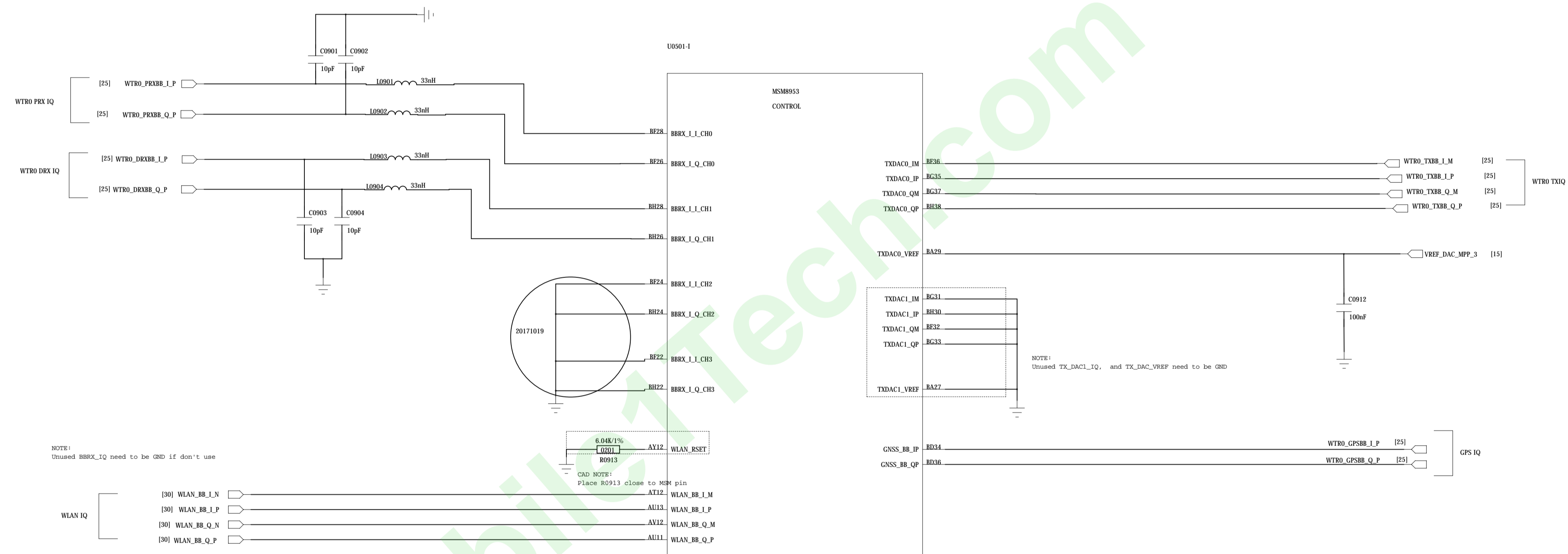

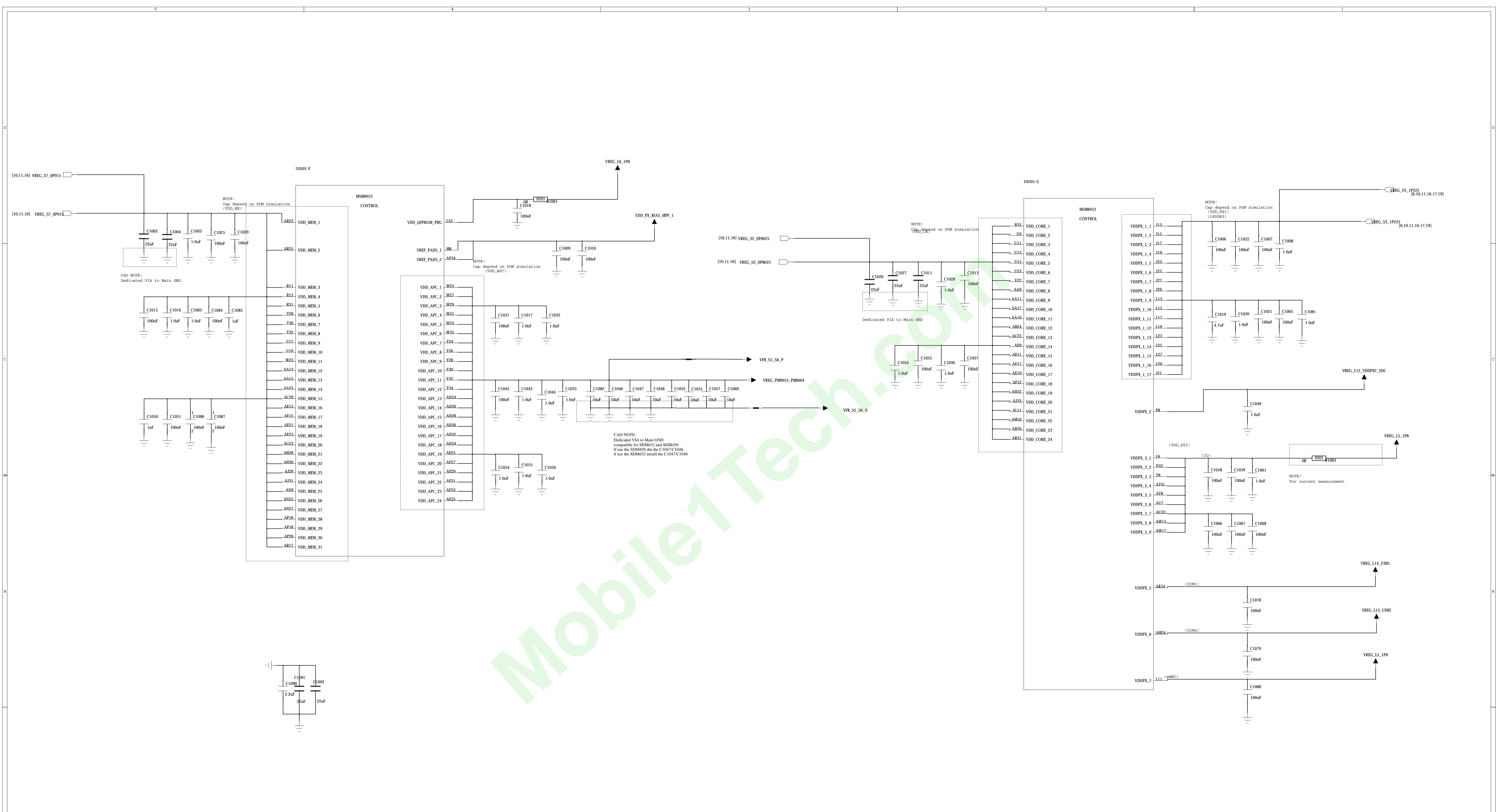

Mobile1Tech.com

NOT TO BE USED, COPIED, REPRODUCED IN WHOLE OR IN PART, NOR ITS CONTENTS REVEALED IN ANY MANNER TO OTHERS WITHOUT THE EXPRESS WRITTEN PERMISSION OF QUALCOMM.

MSM8953 POWER1

CAD NOTE:
About star route from PMIC output Cap:

Note: Connect SDM pins (AG7, AH10 and AE7) to GND if DSI1 is not used.

Note: Respective Camera pins can be left open if not used.

Float AC7 pin if CAM0 not used

Float AA7 pin if CAM1 not used

Float W7 pin if CAM2 not used

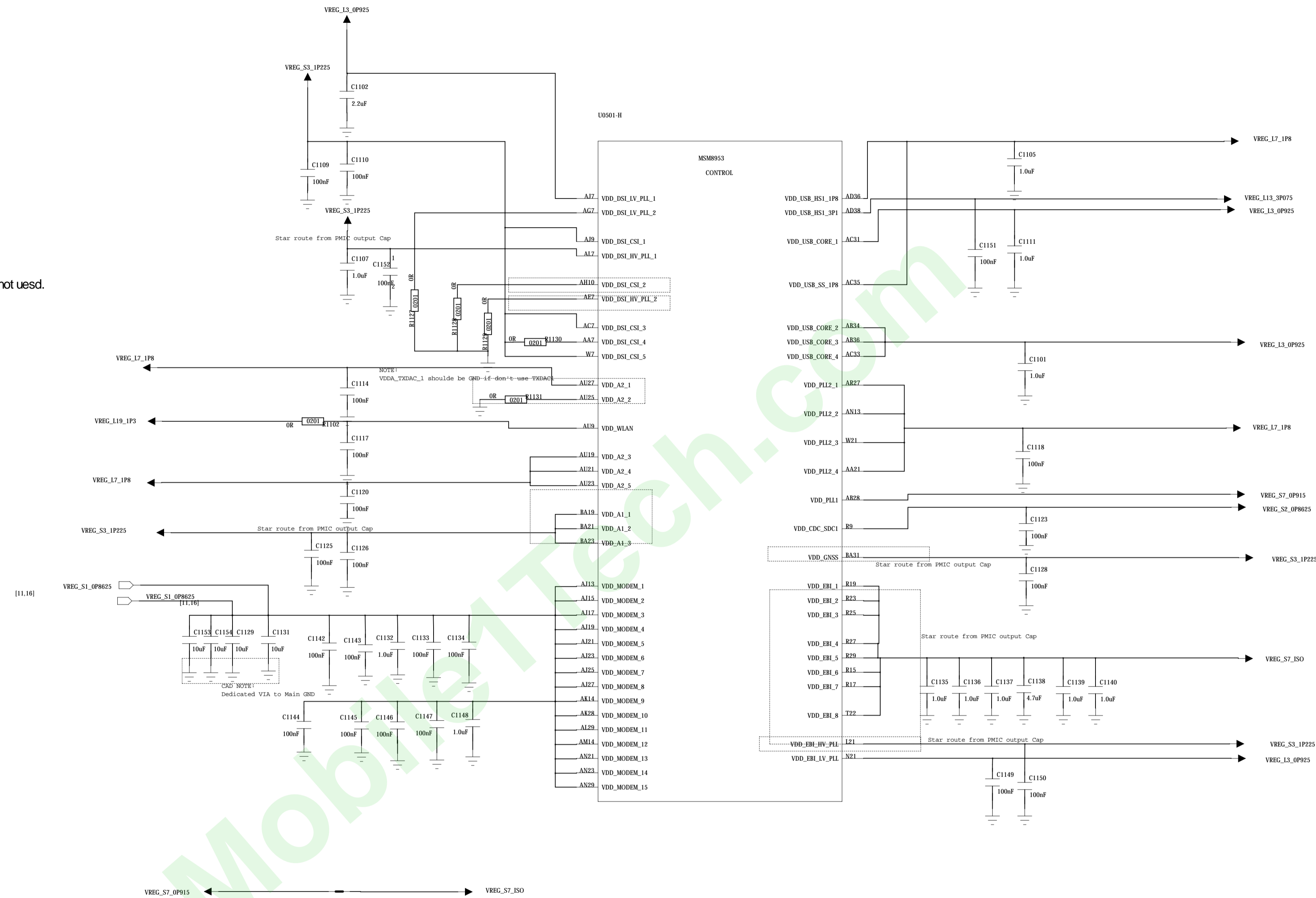

MSM8953 POWER2

NOT TO BE USED, COPIED, REPRODUCED IN WHOLE OR IN PART, NOR ITS CONTENTS REVEALED IN ANY MANNER TO OTHERS WITHOUT THE EXPRESS WRITTEN PERMISSION OF QUALCOMM.

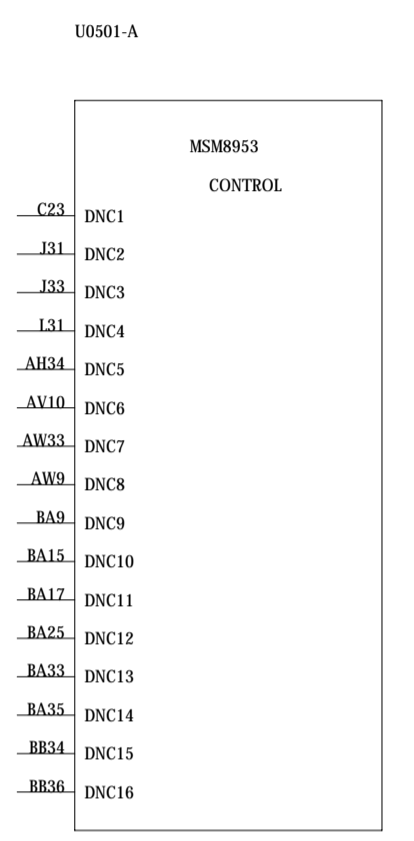
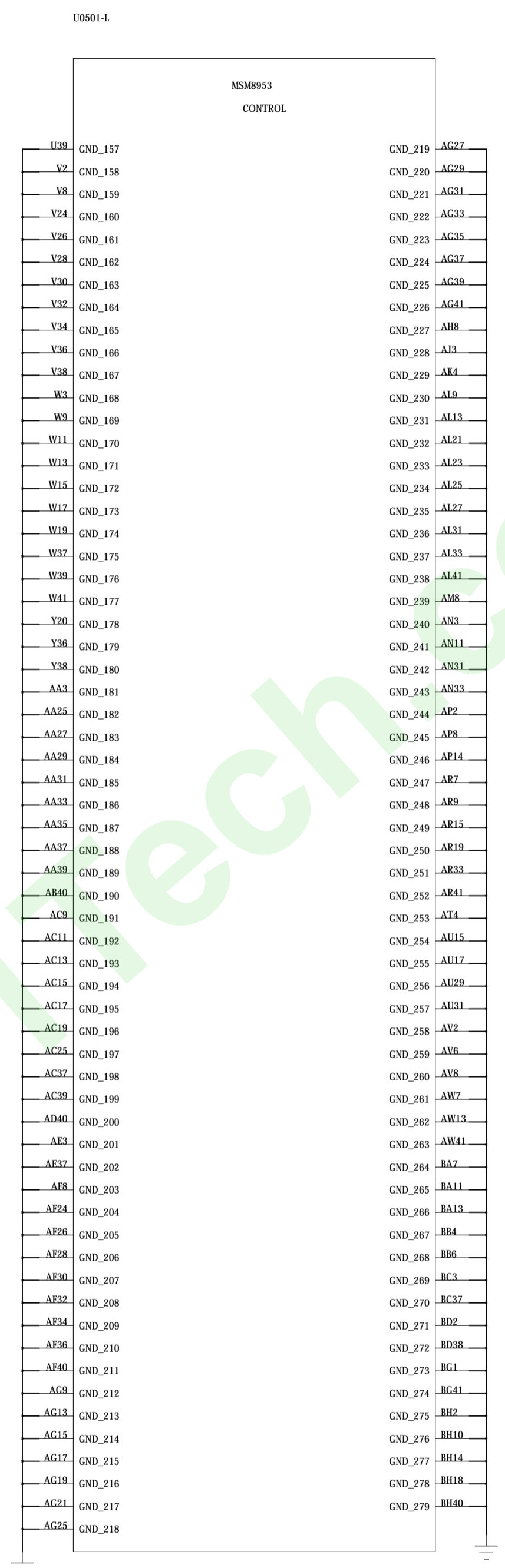
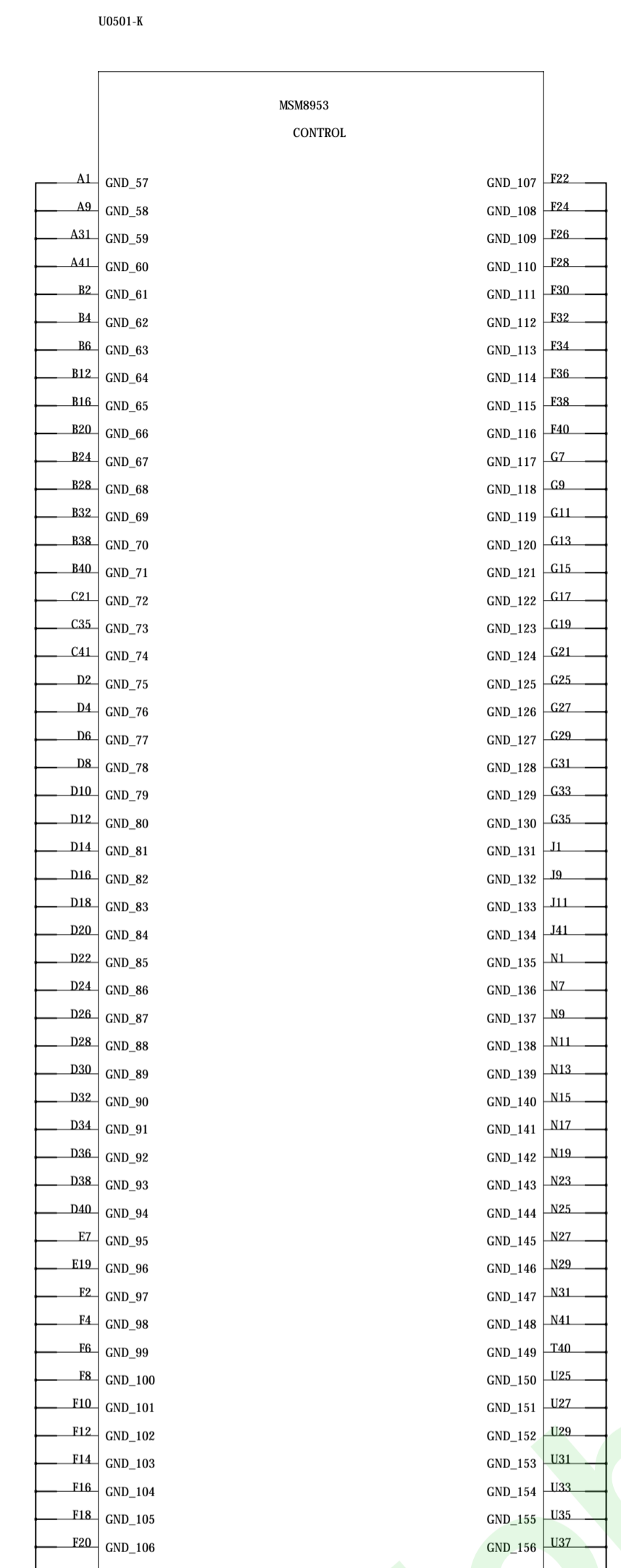
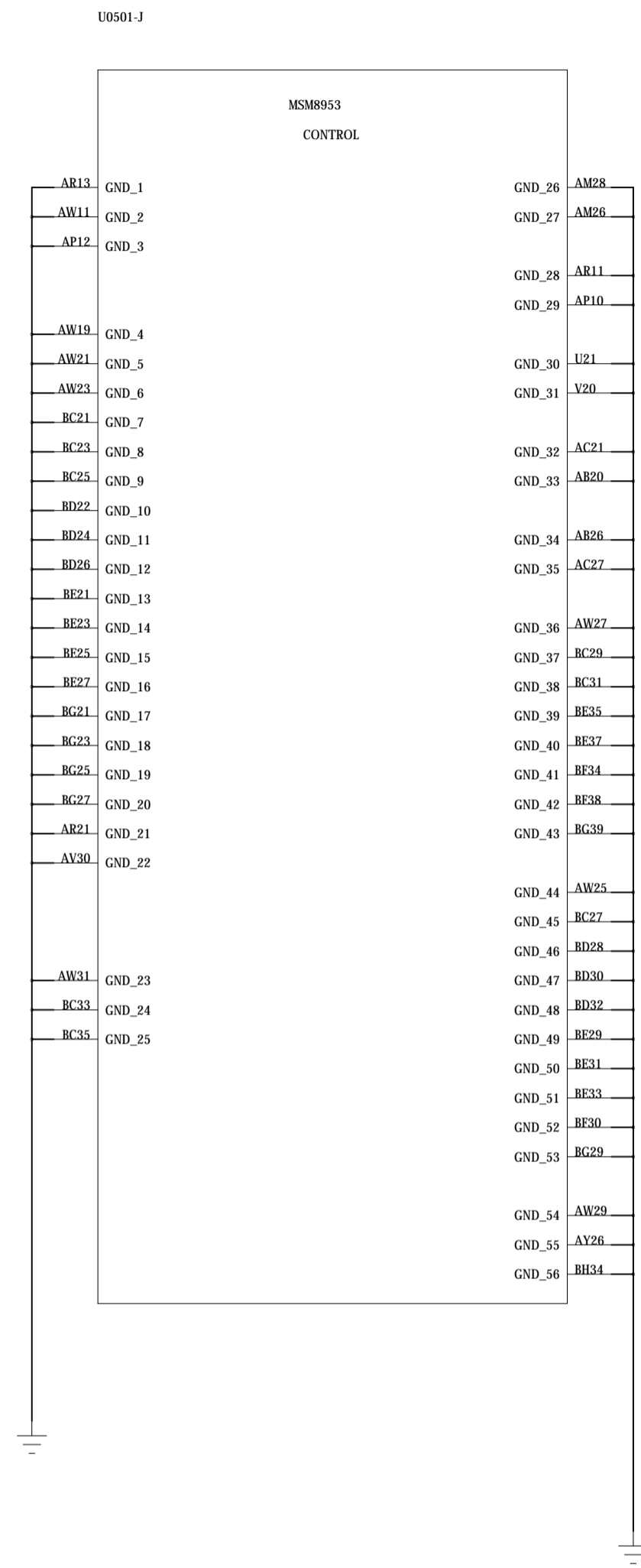

Use C1301= 4.7uF for Single Charging Config
 Use C1301 = 2.2uF for Parallel Charging Config

PMI632 VIN limit 10V

BAT_THERM have the internal pull-up resistor
 The pull up options are 30K,100K,400K

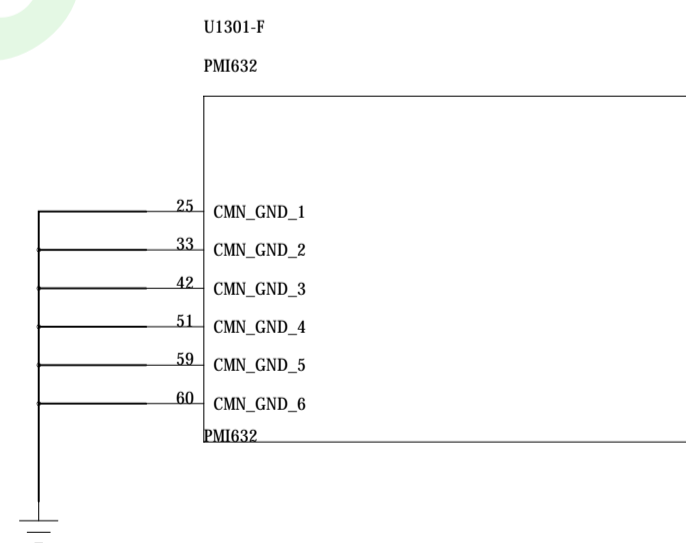
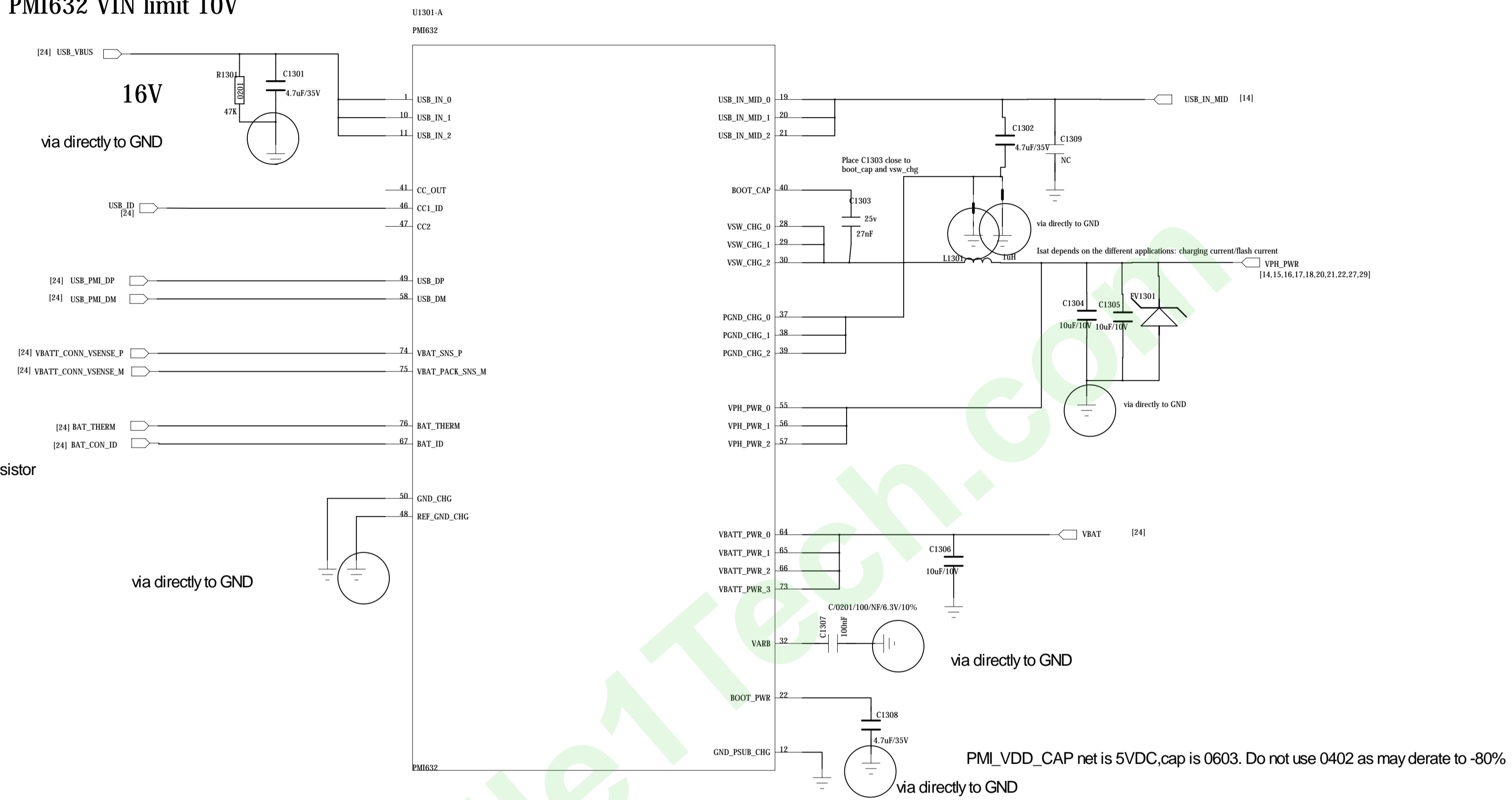

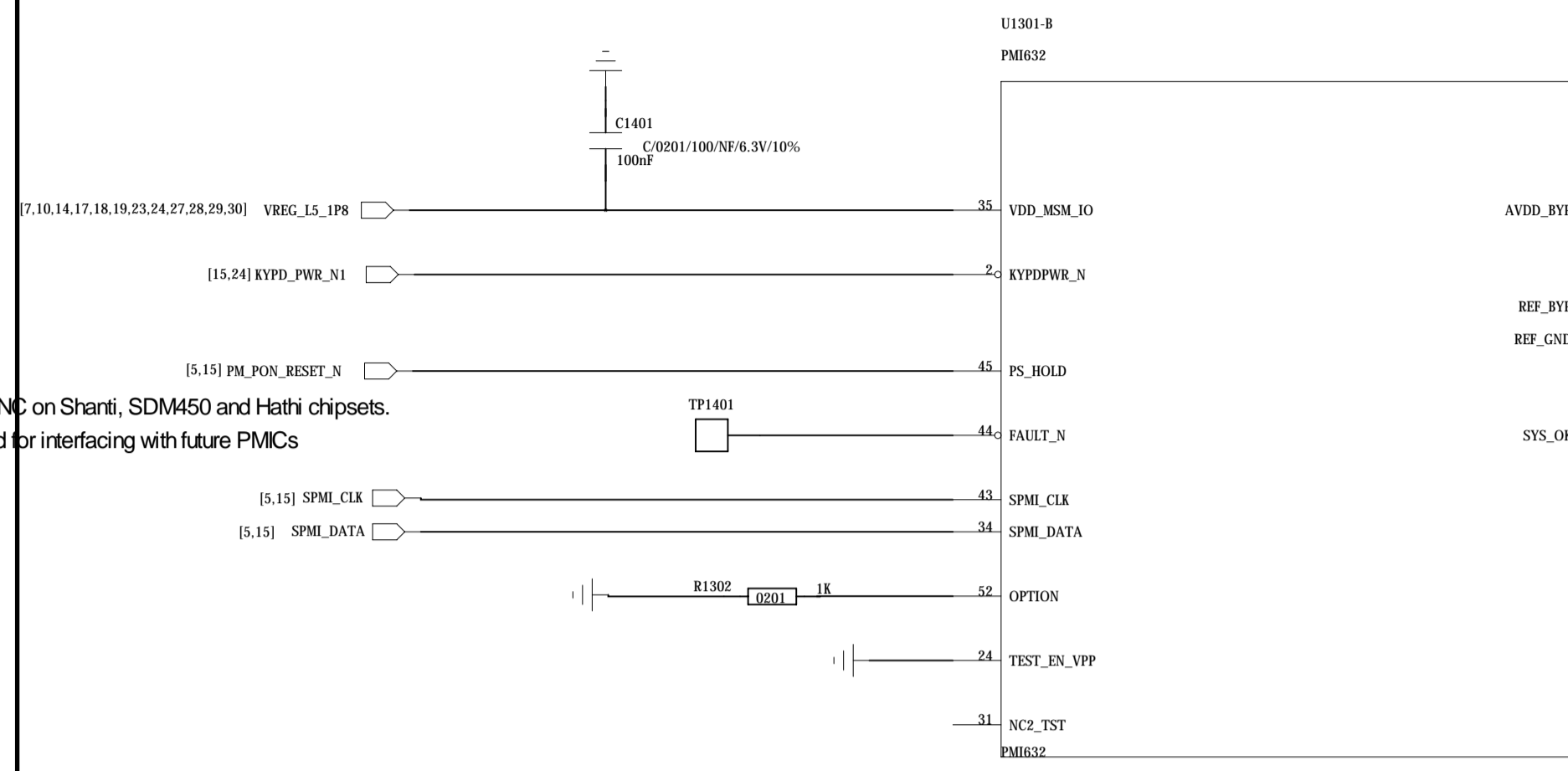

AVDD_BYP should be routed away from noisy traces
 Trace from pin to cap and ONE dedicated via from cap to main grounding plane.
 Dedicated trace from REF_BYP REF_GND to cap
 REF_BYP and REF_GND should be routed away from noisy trace

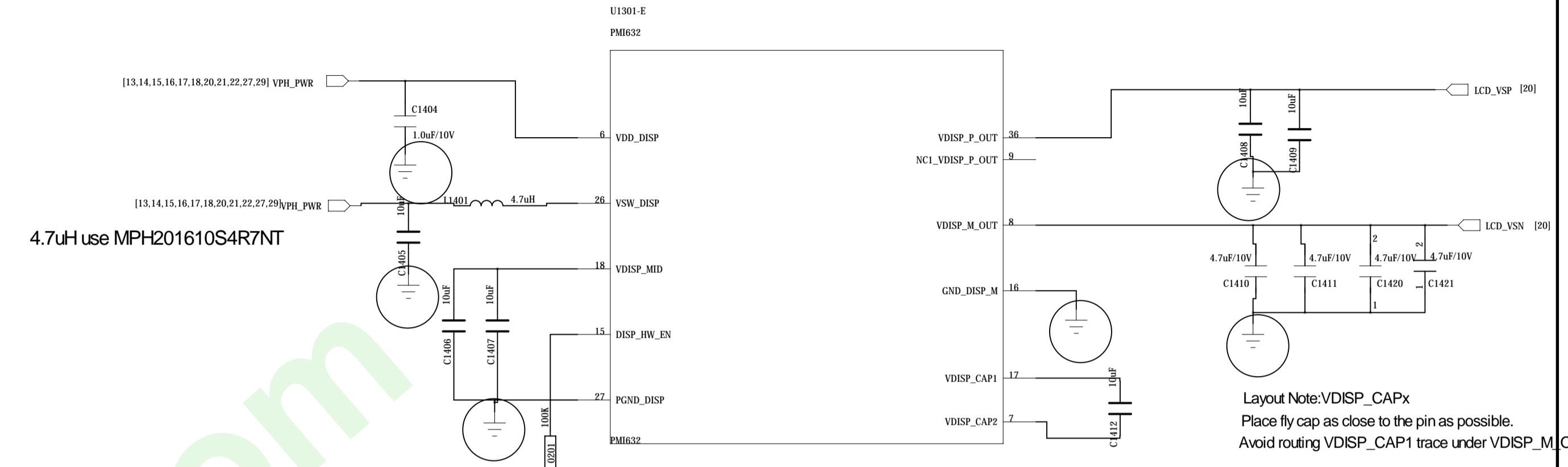

4.7uH use MPH201610S4R7NT

Layout Note: DISP_HW_EN
 This signal is used for "Display Tap to Wake"
 If unused in HW, this pin should be connected to GND
 Bench DC - Connect to a DIO for testability

Layout Note: VDISP_CAPx
 Place fly cap as close to the pin as possible.
 Avoid routing VDISP_CAP1 trace under VDISP_M_OUT.

OPTION	PON Configuration	PD Resistance
1	SPM,uUSB	1K
2	I2C,uUSB	22K
7	I2C,TypeC	510K
	SPM,TypeC	1M

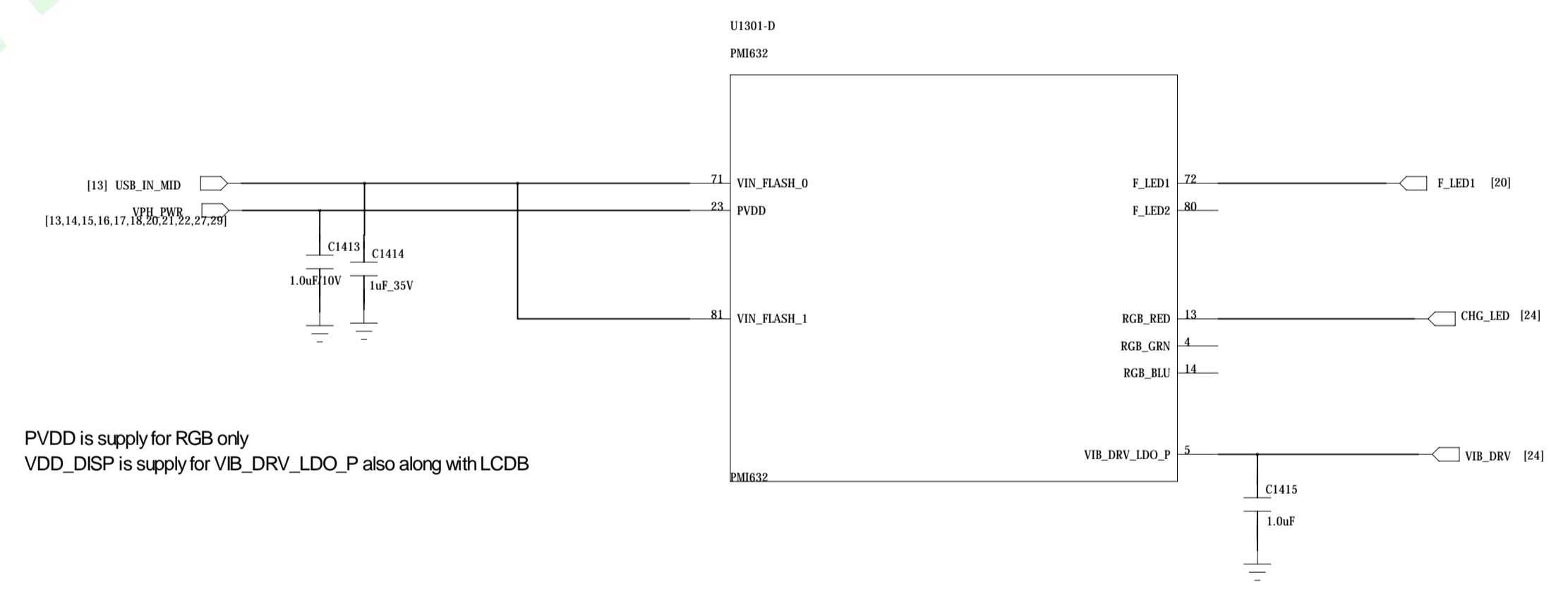
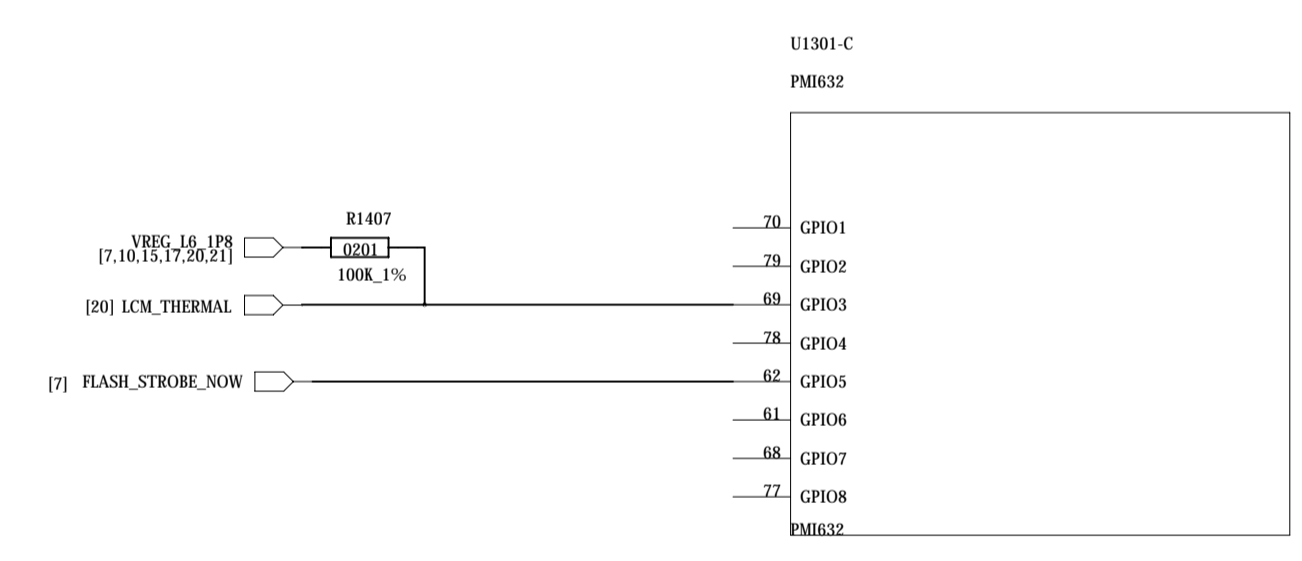

PVDD is supply for RGB only
 VDD_DISP is supply for VIB_DRV_LDO_P also along with LCDB

Thermister / To sense board level temperature

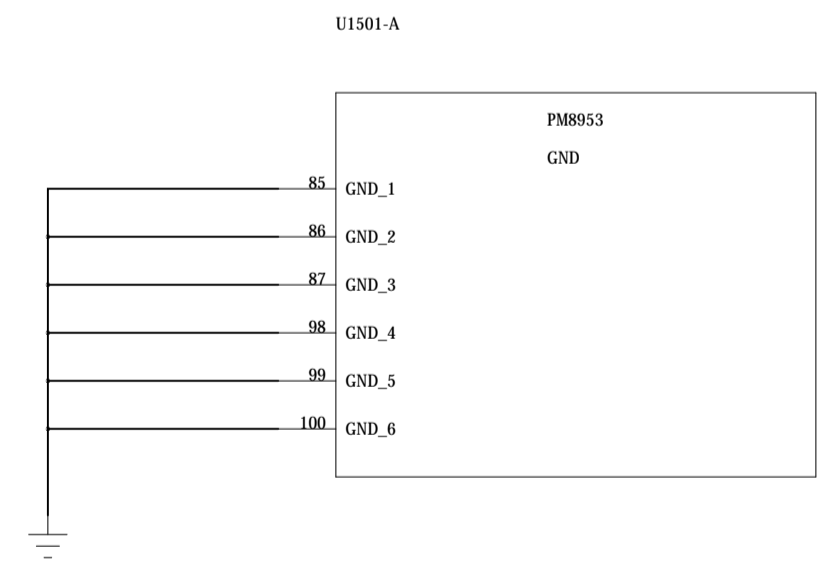
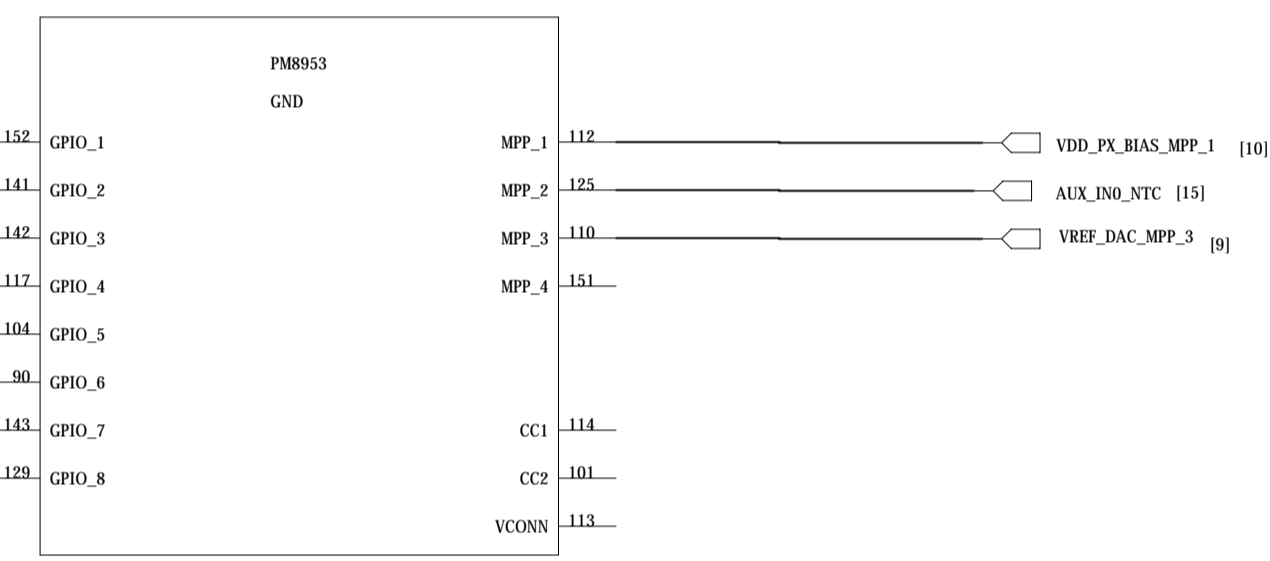
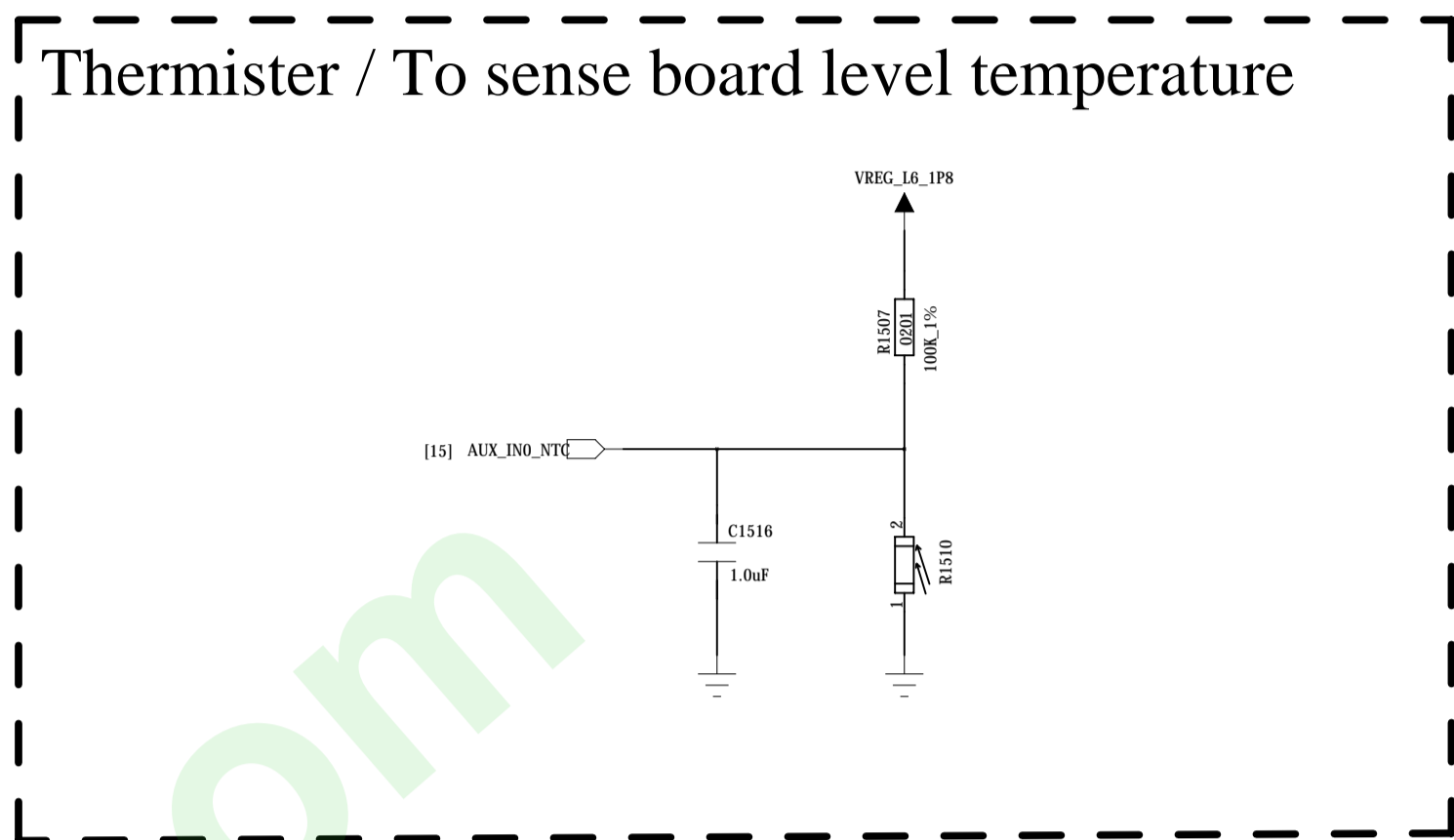
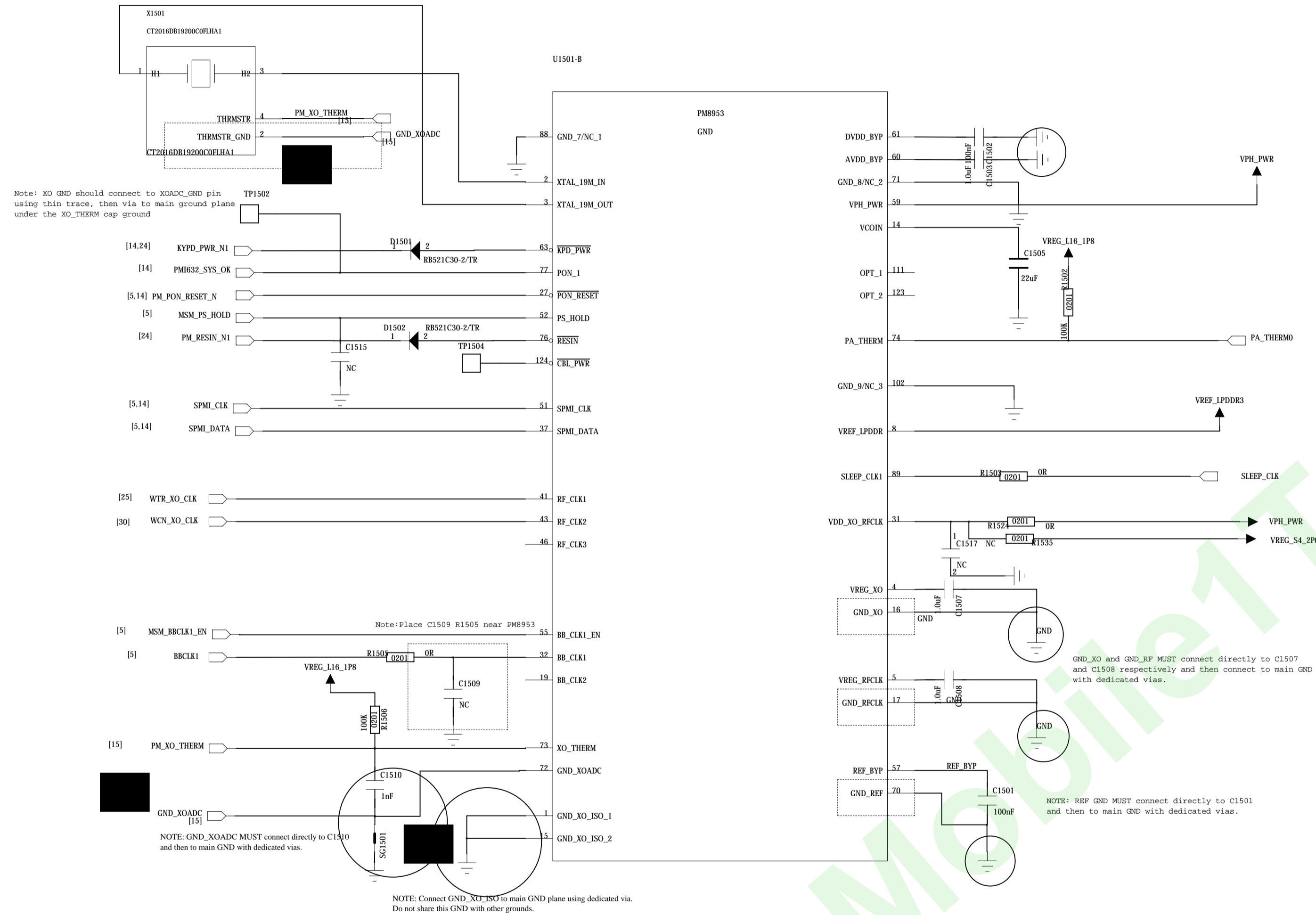

NOT TO BE USED, COPIED, REPRODUCED IN WHOLE OR IN PART, NOR ITS CONTENTS REVEALED IN ANY MANNER TO OTHERS WITHOUT THE EXPRESS WRITTEN PERMISSION OF QUALCOMM.

PM8953 Control/Interface

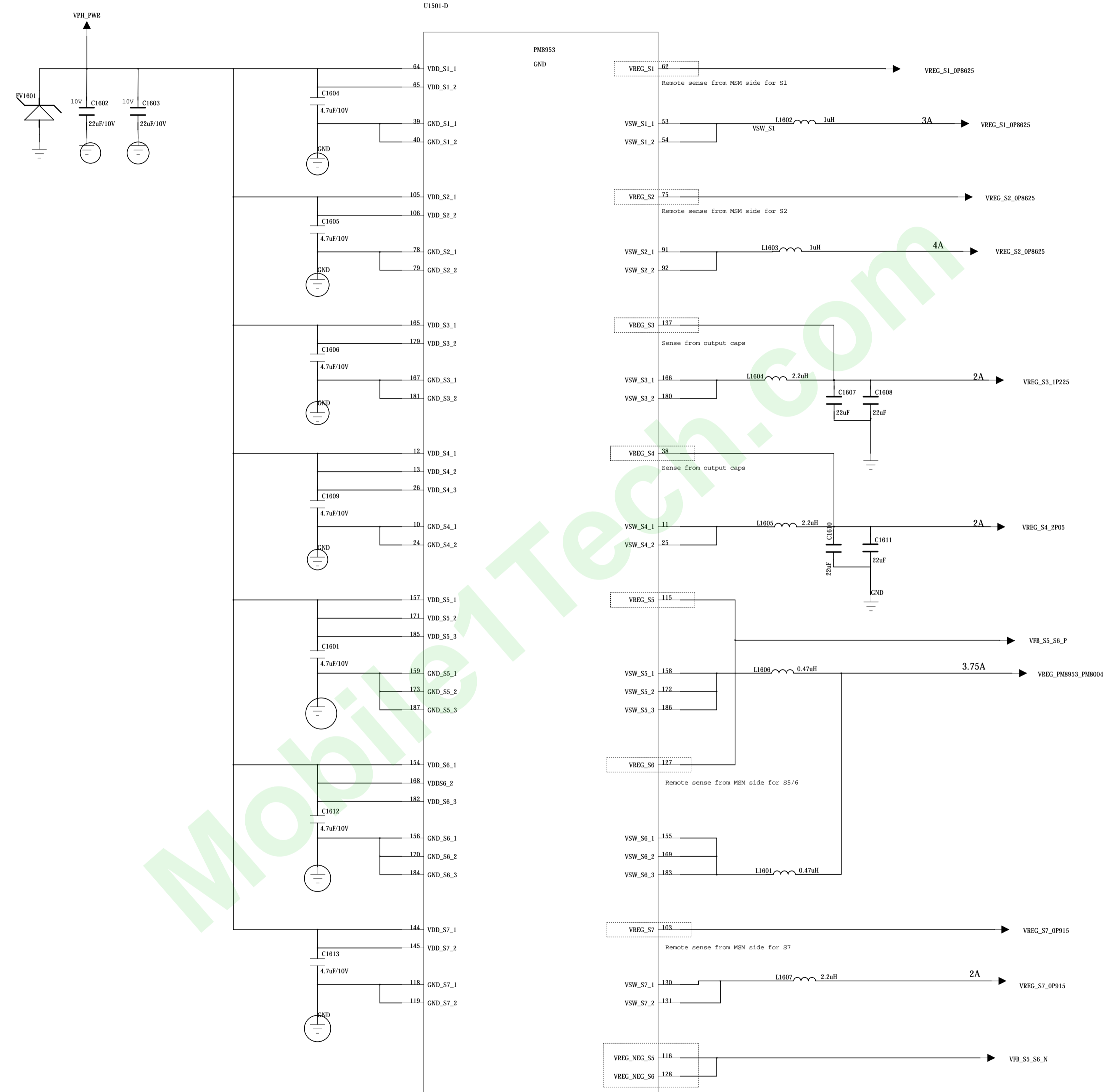

NOT TO BE USED, COPIED, REPRODUCED IN WHOLE OR IN PART, NOR ITS CONTENTS REVEALED IN ANY MANNER TO OTHERS WITHOUT THE EXPRESS WRITTEN PERMISSION OF QUALCOMM.

PM8953 SMPS

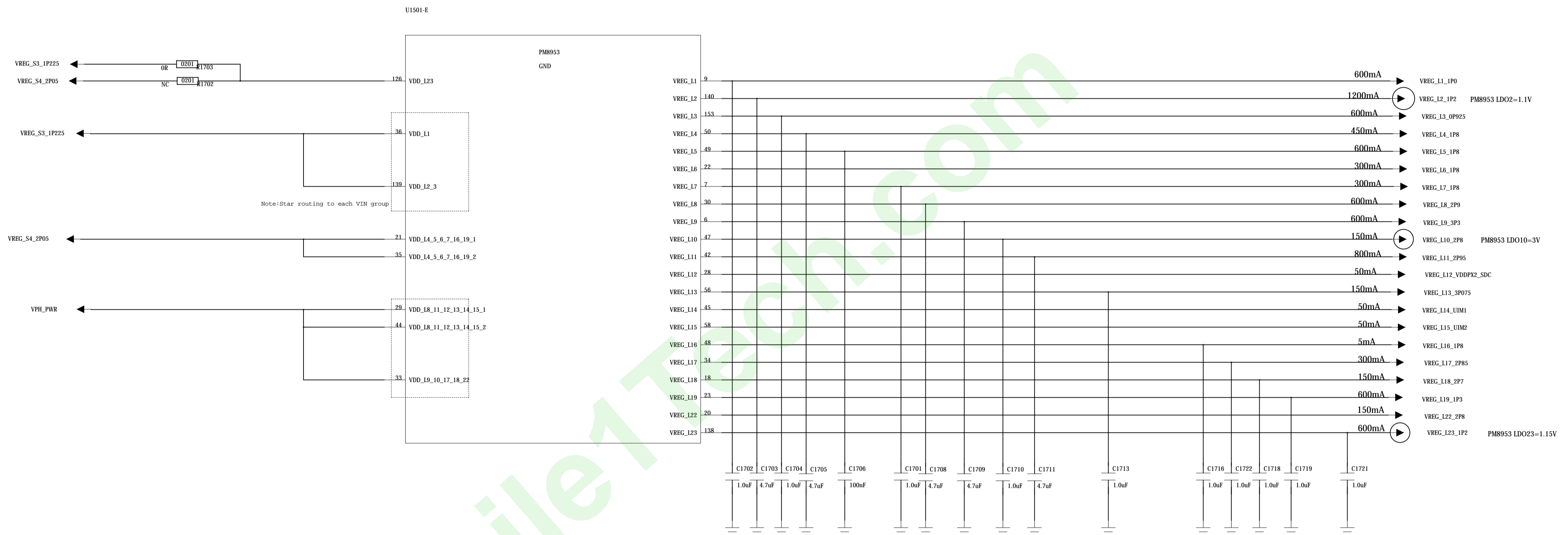

Table 3-7 PM8953 regulators and their

Function	Circuit type	Default
S1	SMPS	
S2	SMPS	
S3	SMPS	
S4	SMPS	
S5	SMPS	
S6	SMPS	
S7	SMPS	
L1	NMOS LDO	
L2	NMOS LDO	
L3	NMOS LDO	
L4	PMOS LDO	
L5 ⁴	PMOS LDO	
L6	PMOS LDO	
L7	PMOS LDO	
L8	PMOS LDO	
L9	PMOS LDO	$V_{out} = V_{in} - V_{drop}$
L10	PMOS LDO	
L11 ⁵	PMOS LDO	

Table 3-7 PM8953 regulators and their

Function	Circuit type	Default
L12 ⁴	PMOS LDO	
L13	PMOS LDO	
L14 ⁵	PMOS LDO	
L15 ⁵	PMOS LDO	
L16	PMOS LDO	
L17	PMOS LDO	
L18	PMOS LDO	
L19	NMOS LDO	
L20	Low-noise LDO	
L21	Low-noise LDO	
L22	PMOS LDO	
L23	NMOS LDO	

⁴ All regulators have default output voltages.

NOT TO BE USED, COPIED, REPRODUCED IN WHOLE OR IN PART, NOR ITS CONTENTS REVEALED IN ANY MANNER TO OTHERS WITHOUT THE EXPRESS WRITTEN PERMISSION OF QUALCOMM.

PM8953 LDO

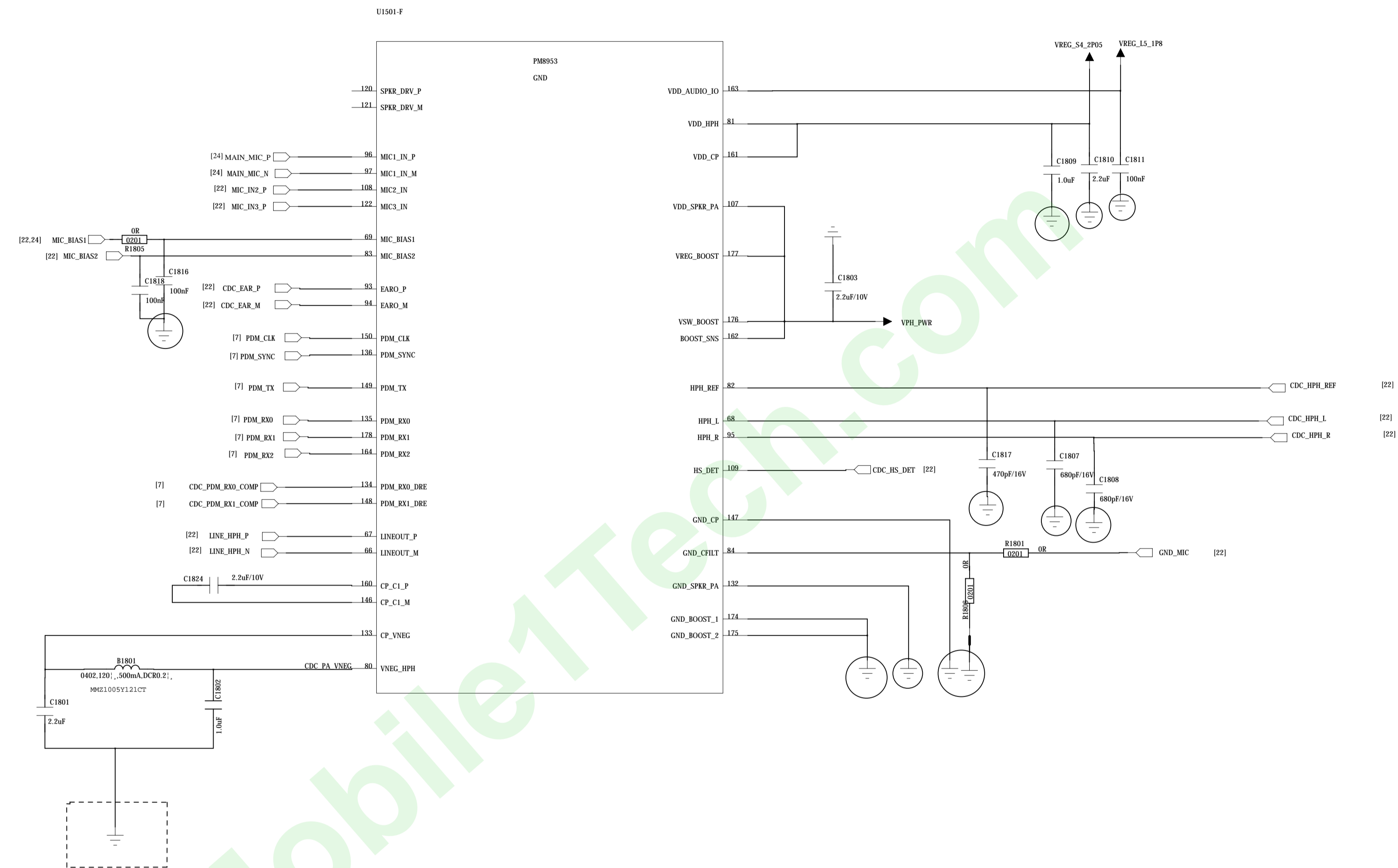

NOT TO BE USED, COPIED, REPRODUCED IN WHOLE OR IN PART, NOR ITS CONTENTS REVEALED IN ANY MANNER TO OTHERS WITHOUT THE EXPRESS WRITTEN PERMISSION OF QUALCOMM.

PM8953 CODEC/Audio PA

QUALCOMM Technologies, Inc. 5750 La Jolla Village Drive San Diego, CA 92121-1714 U.S.A.		
Title		
Sheet		
Size	Name	Rev
Date:	Sheet of	

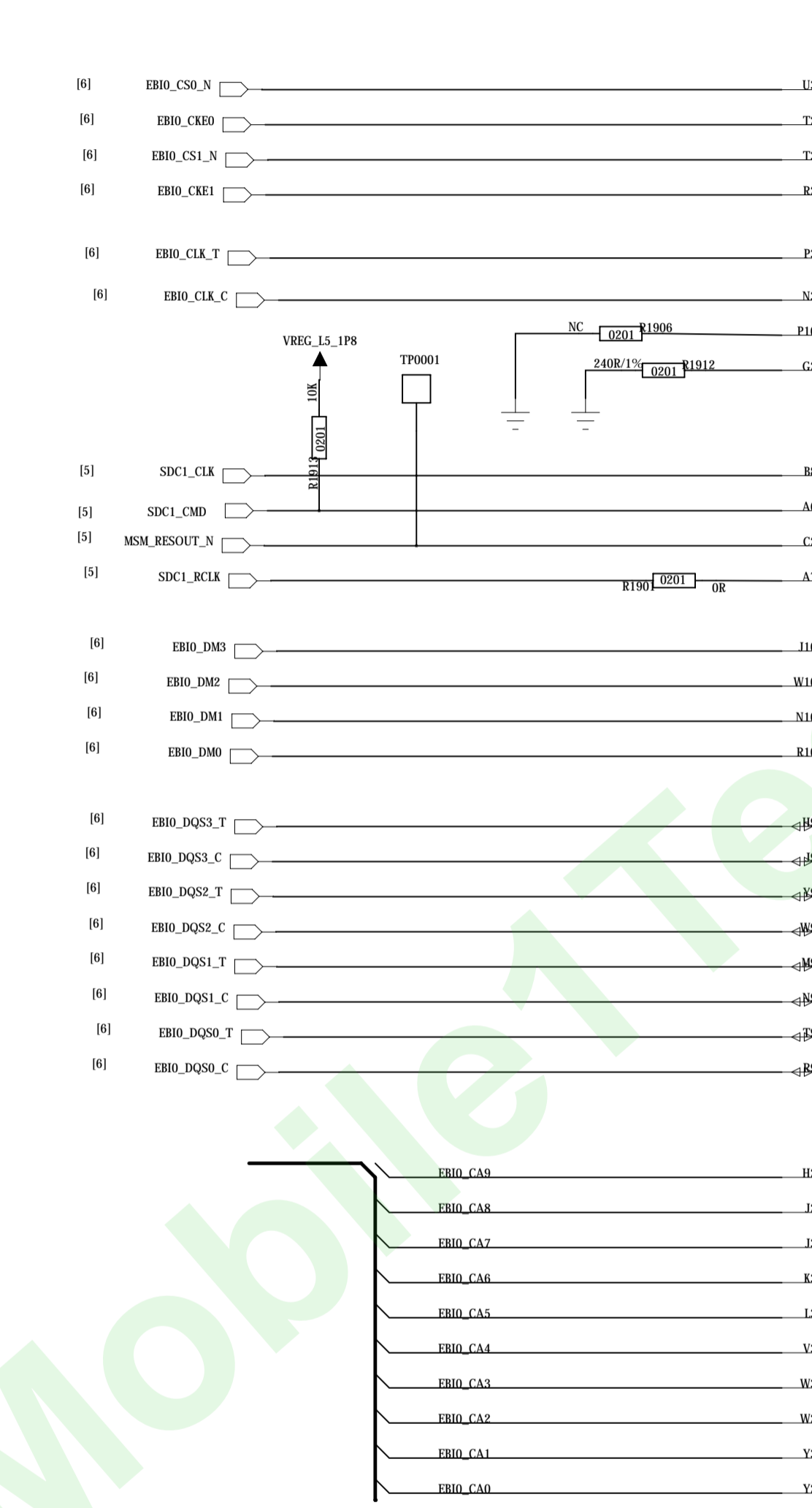
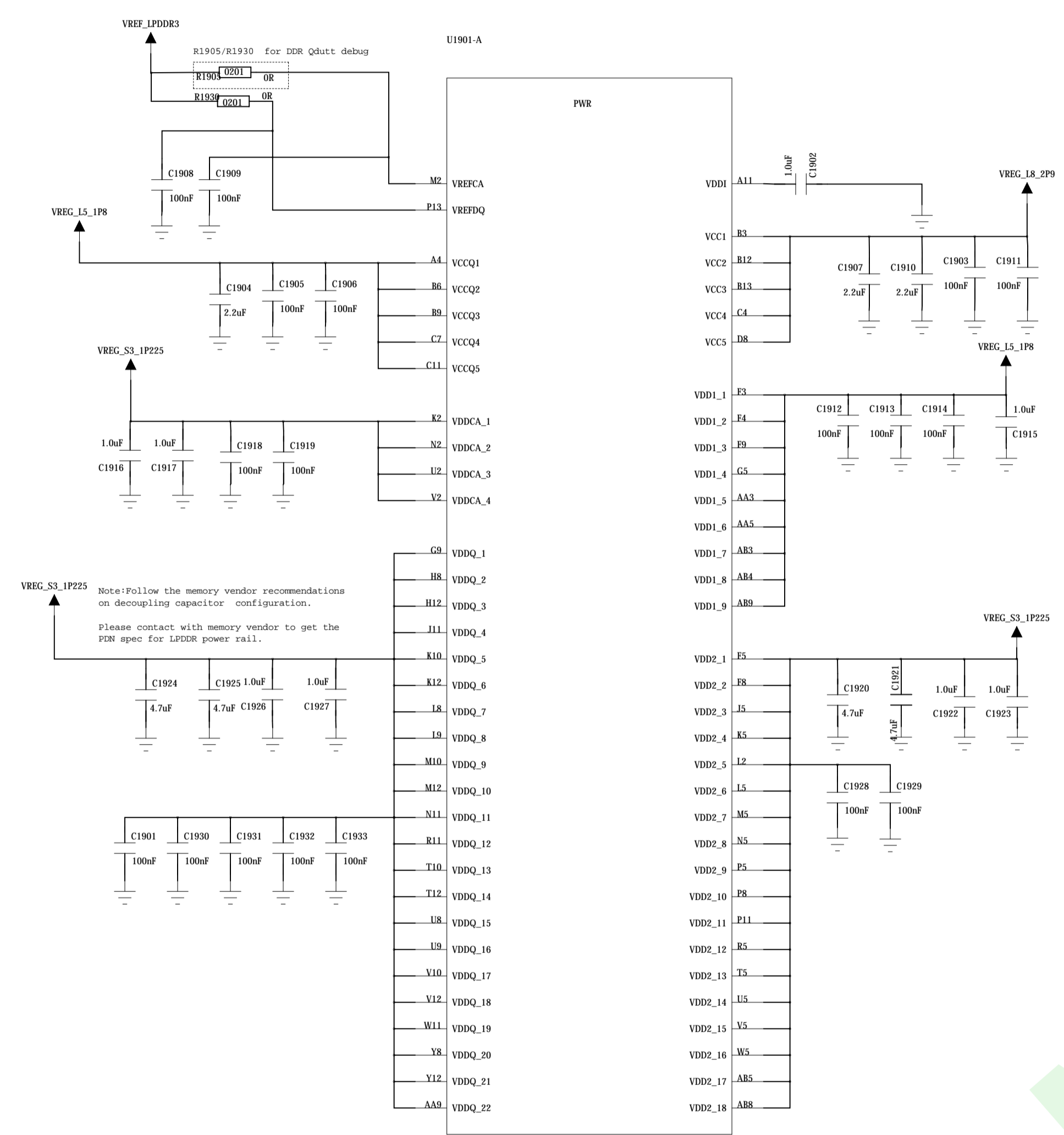

NOT TO BE USED, COPIED, REPRODUCED IN WHOLE OR IN PART, NOR ITS CONTENTS REVEALED IN ANY MANNER TO OTHERS WITHOUT THE EXPRESS WRITTEN PERMISSION OF QUALCOMM.

MEMORY(LPDDR3+EMMC V5.1)

QUALCOMM Technologies, Inc. 5750 La Jolla Village Drive San Diego, CA 92121-1714 U.S.A.	
Title Sheet Size Name Date: _____ of _____ Rev	

REVISION RECORD			
CR	ECO NO.	APPROVED	DATE

Main Camera A

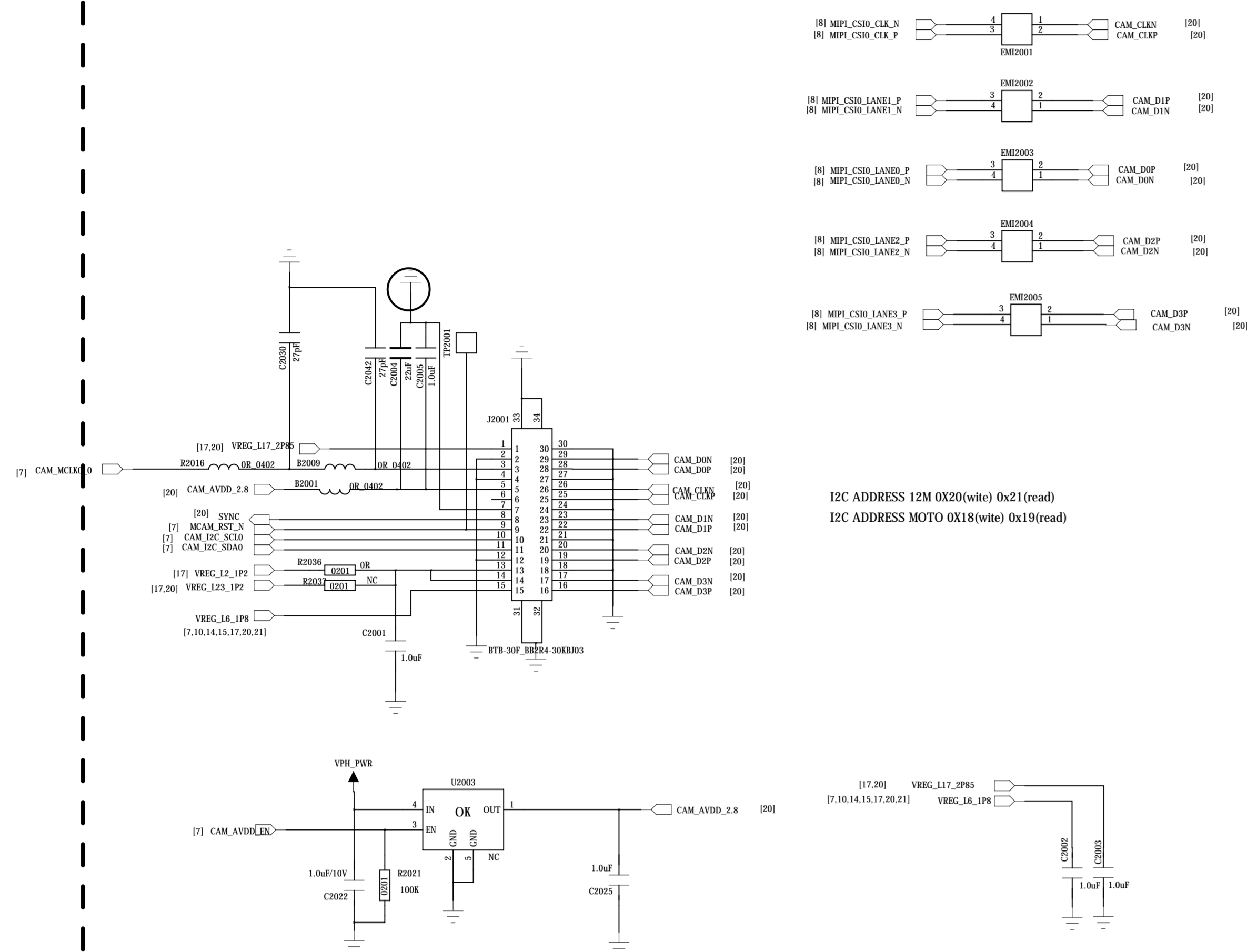

Main Camera B

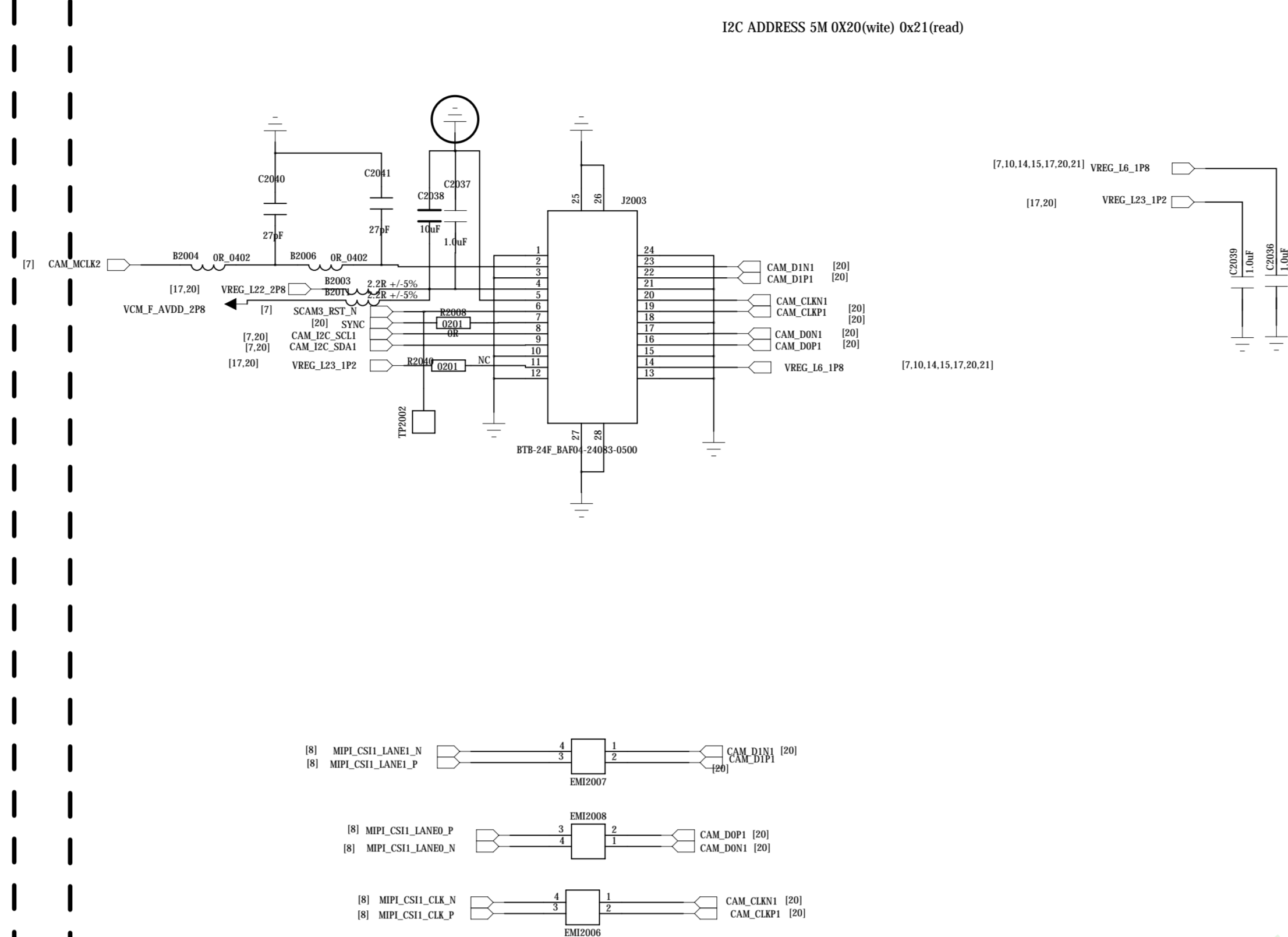

LCM

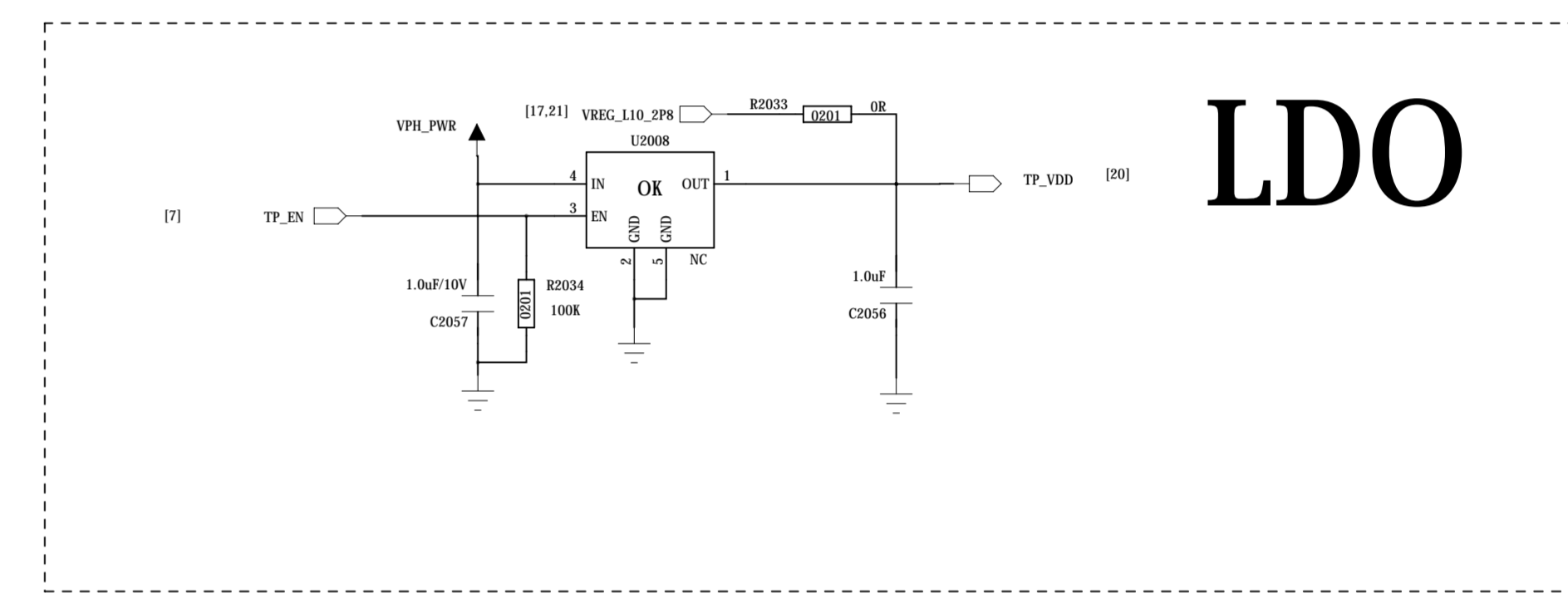
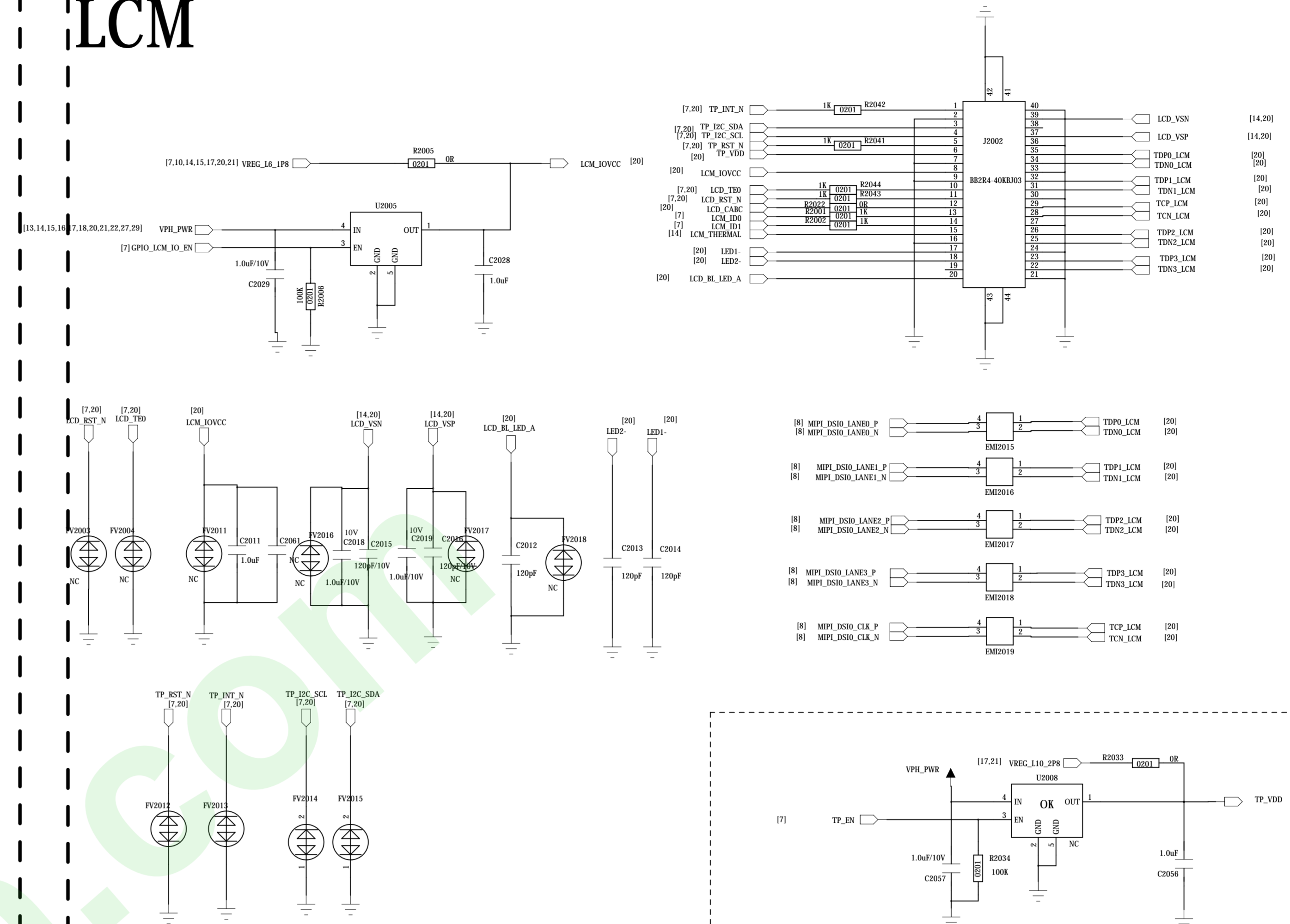

Front Camera

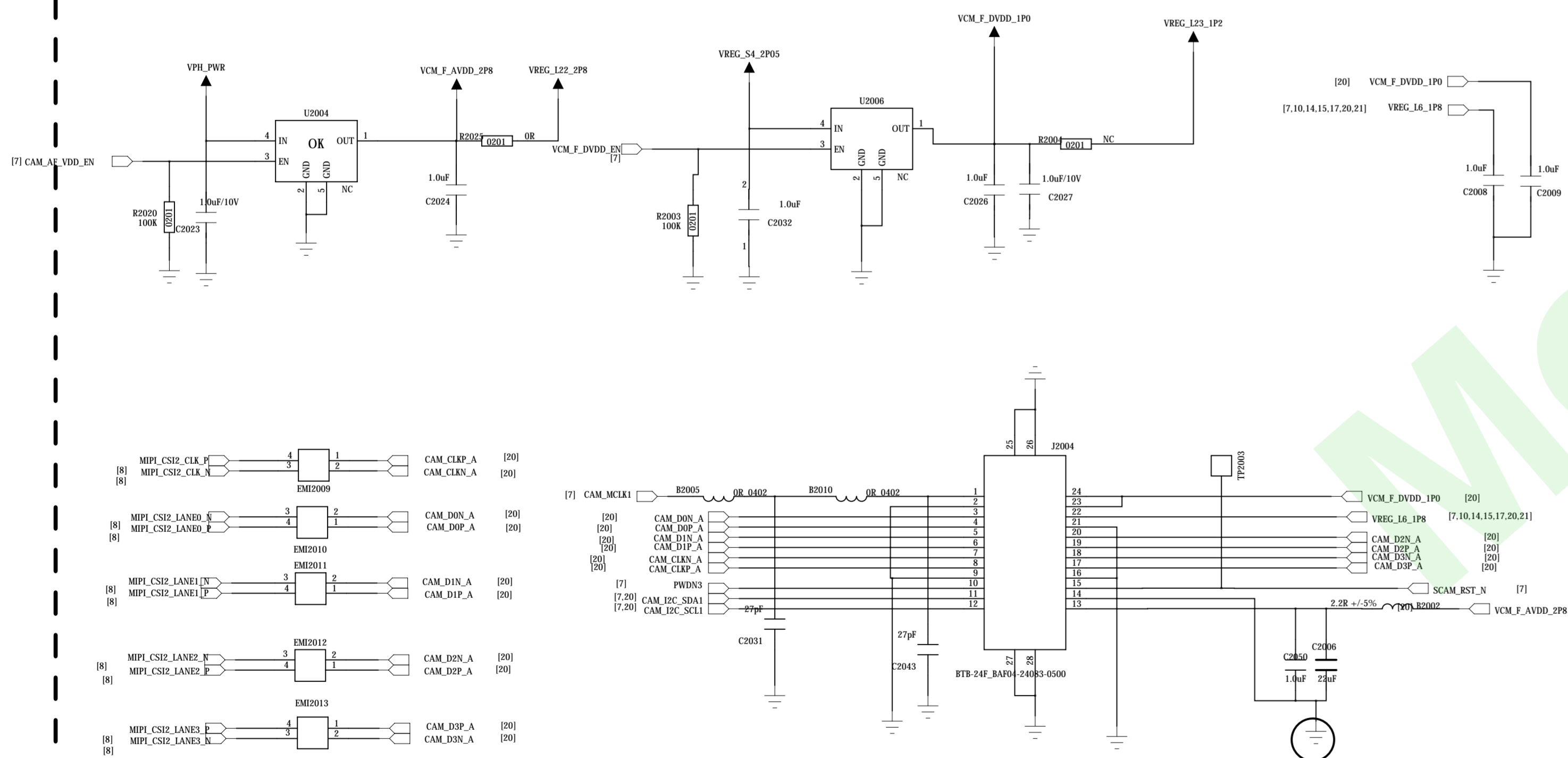

LCM Black Light

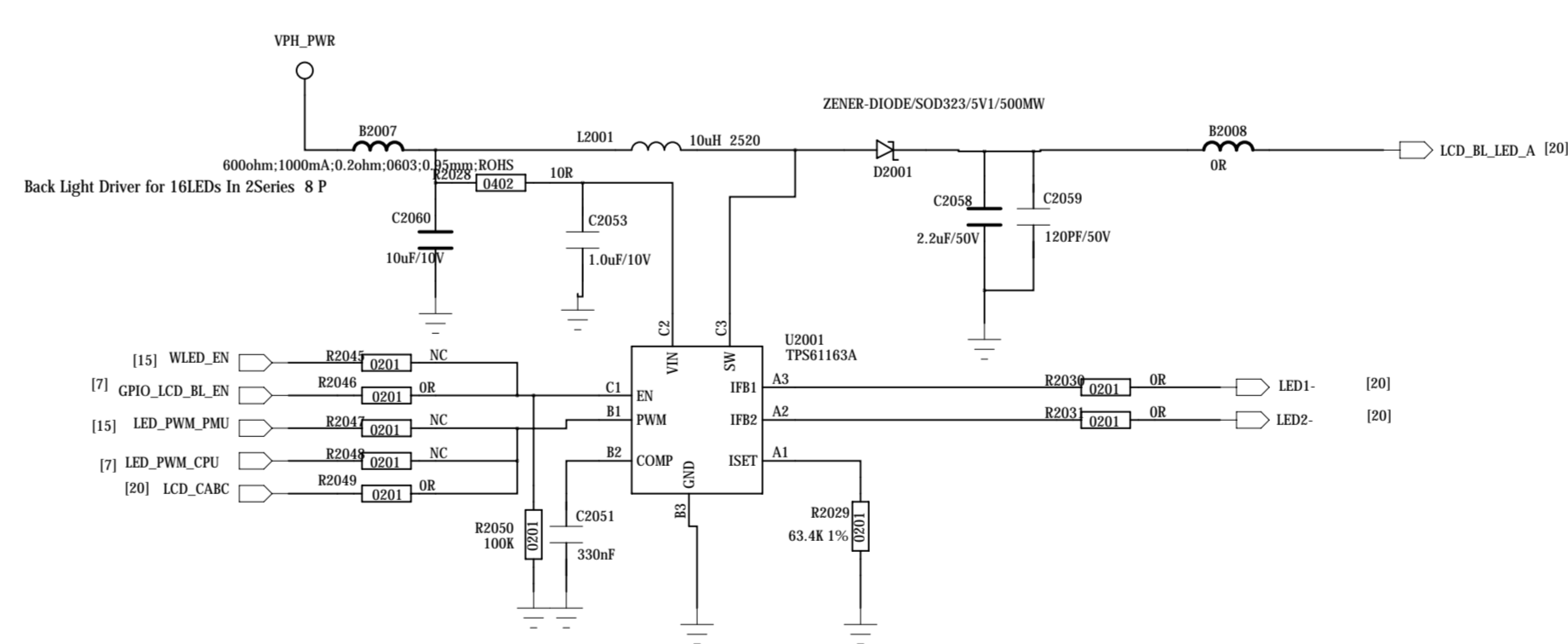

Main FLASHLIGHT

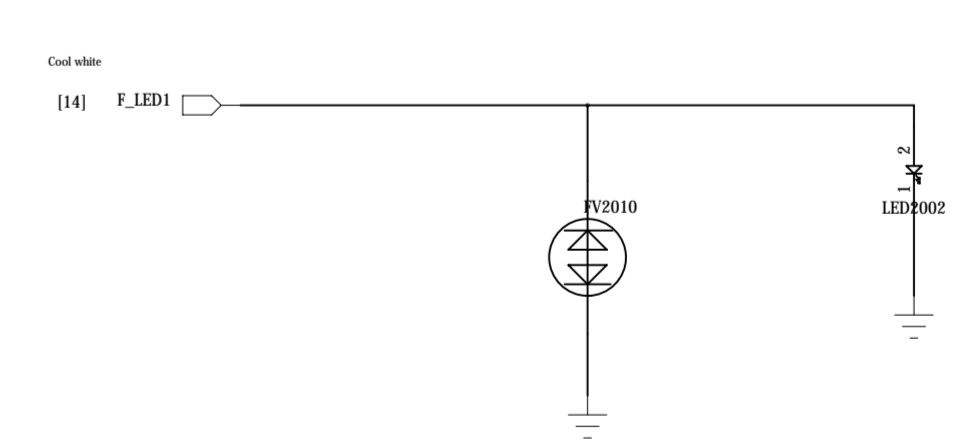

Schematic design notice of "63_PERI_CAMERA_KEYPAD" page.

Note 62-1: The VCC of I2C_0 is pulled to "VCAM_IO_PMU".

Note 62-2: I2C control interface of front camera (with AF) must be assigned to I2C-2 bus when PIP/VIV feature be supported.

Note 62-3: Reserve a capacitor (27pf) on camera's MCLK and shunt it to GND to prevent GPS de-sense.

IC ADDRESS 2M 0X7a(wh) 0x7b(read)

COMPANY: <Company Name>			
TITLE: <Title>			
DRAWN: <Drawn By>	DATE: <Drawn Date>	CODE: <Code>	SIZE: <Size>
CHECKED: <Checked By>	DATE: <Checked Date>	DRAWING NO: <Drawing Number>	REV: <Revision>
QUALITY CONTROL: <QC By>	DATE: <QC Date>	SCALE: <Scale>	
RELEASED: <Released By>	DATE: <Release Date>	SHEET 20 31	

REVISION RECORD			
ITER	REV NO	APPROVED	DATE

M-Sensor

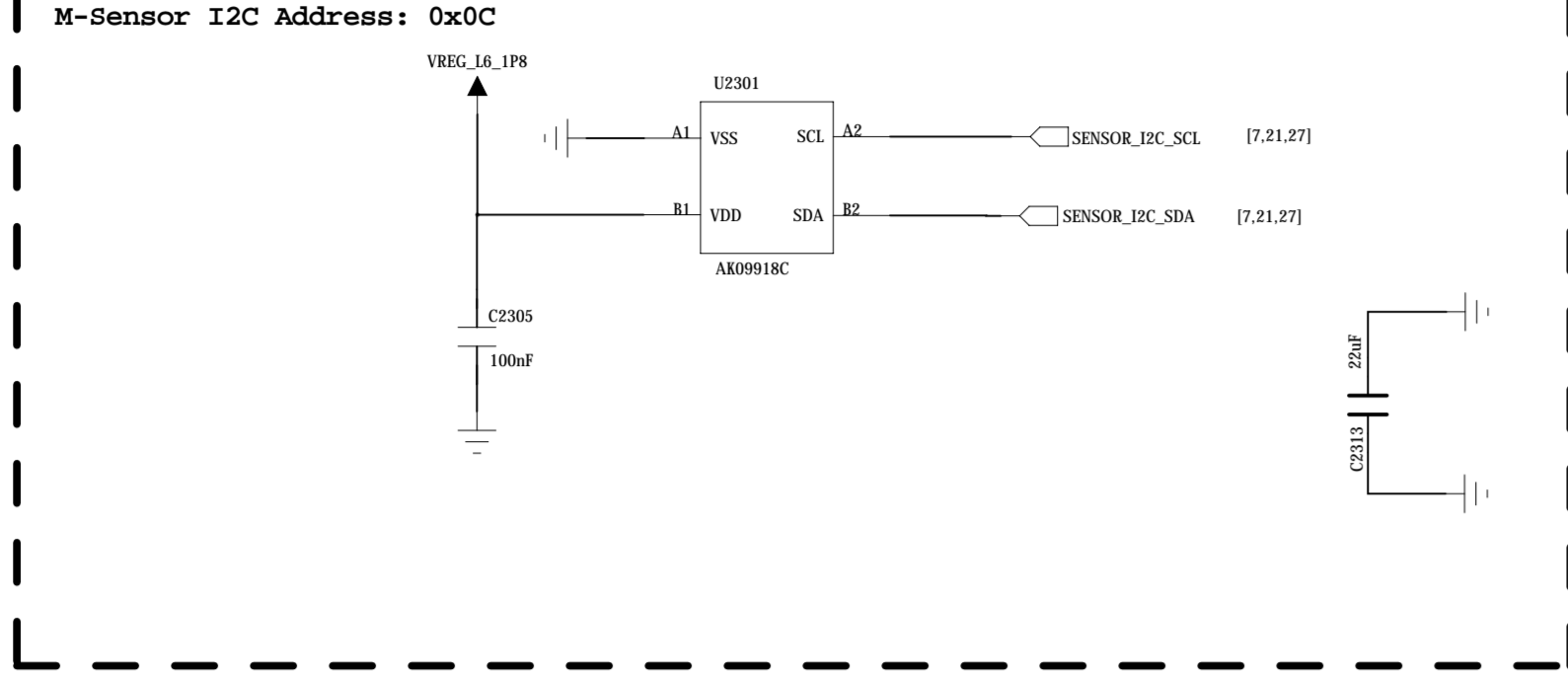

L-SENSOR

P_SENSOR

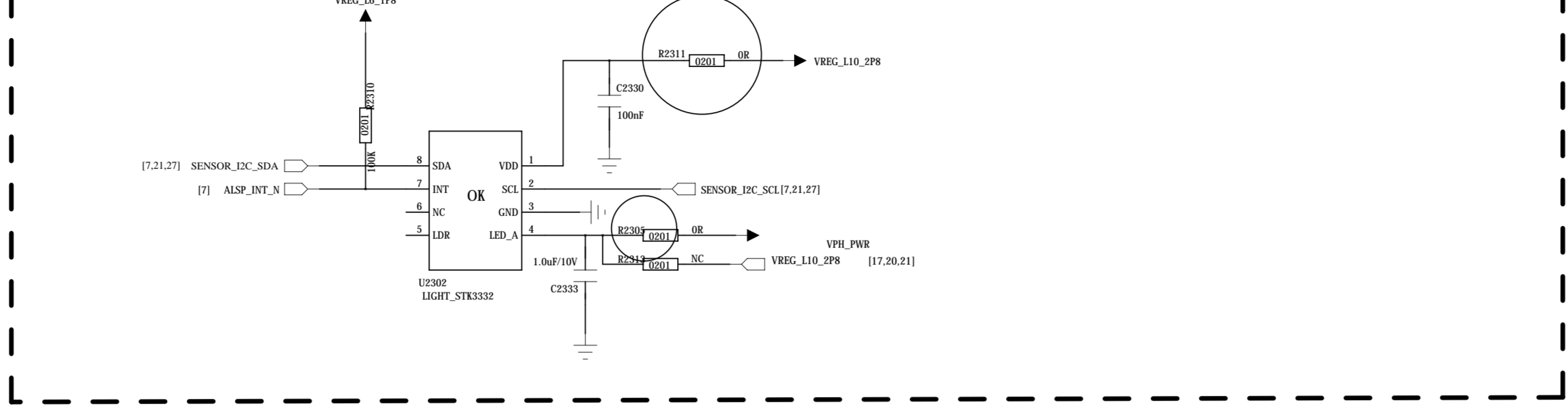

ACC-Sensor

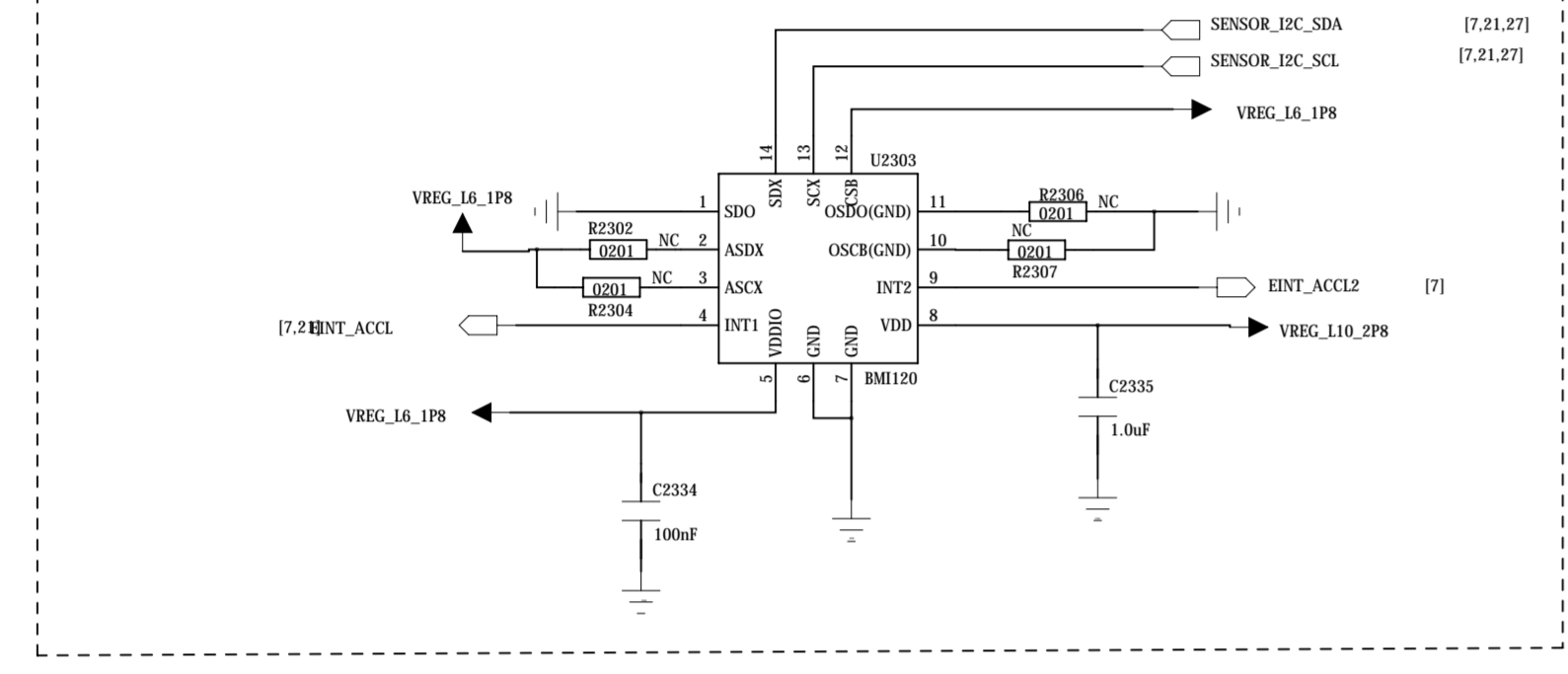

IR

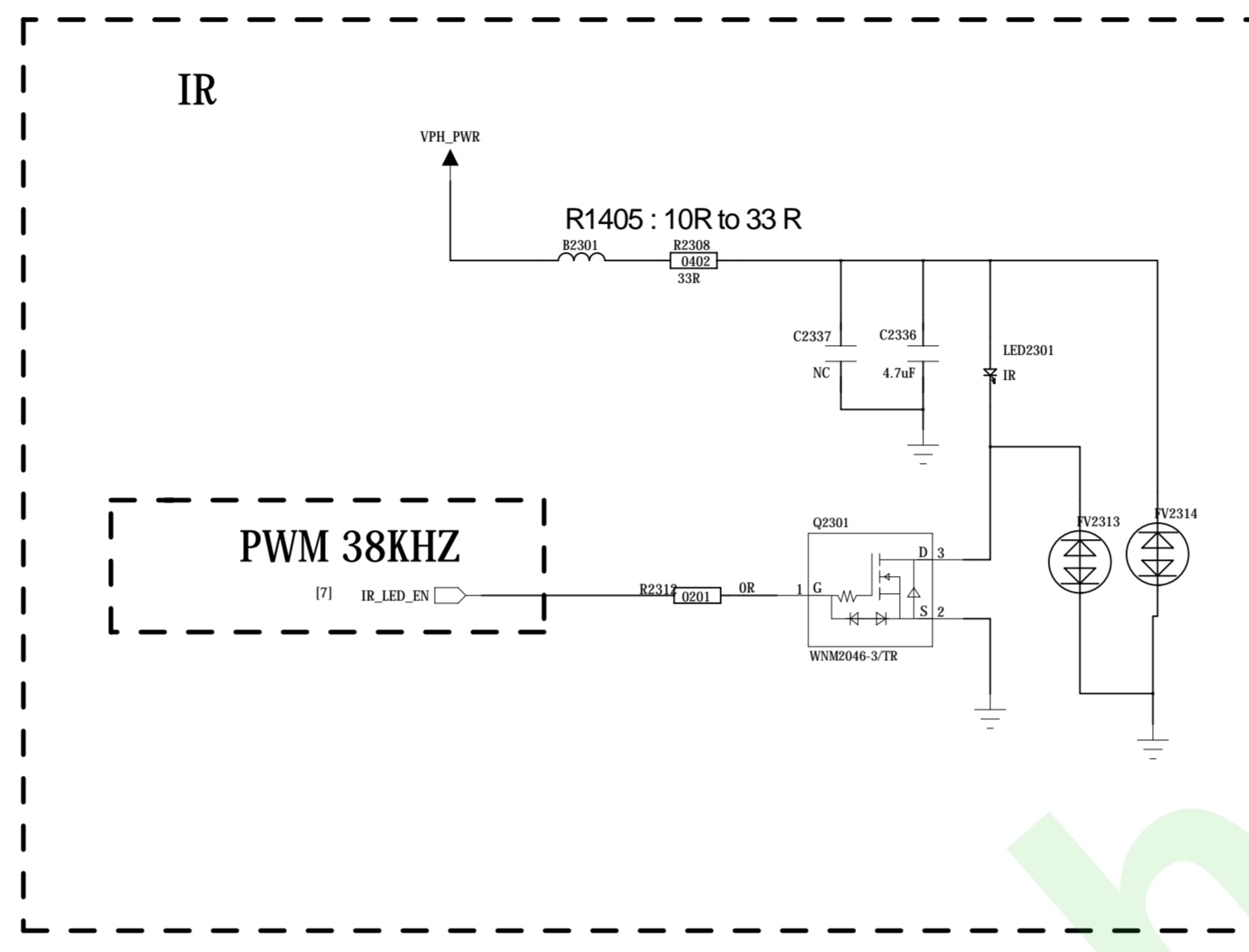

ACC-Sensor

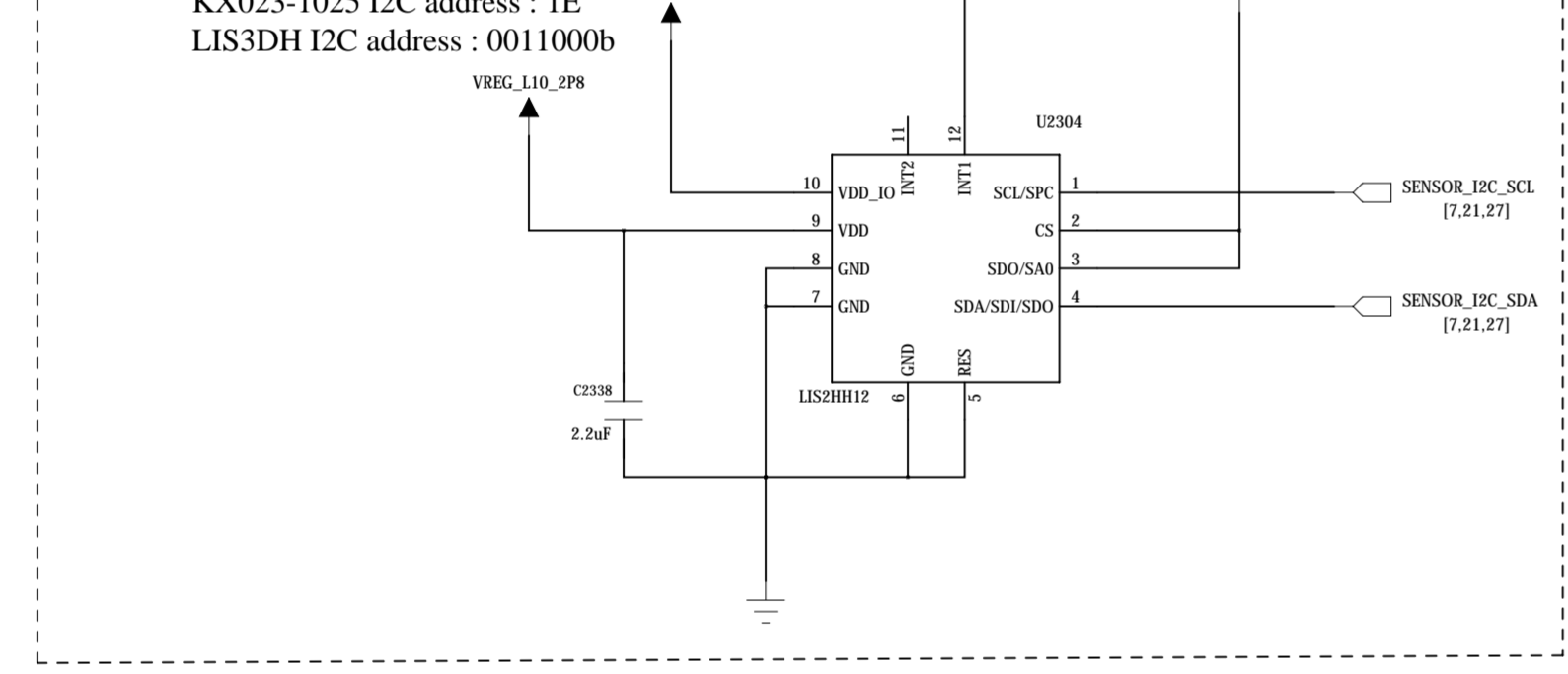

FingerPrint-Sensor

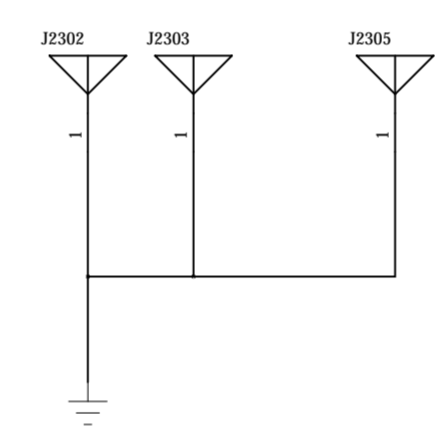
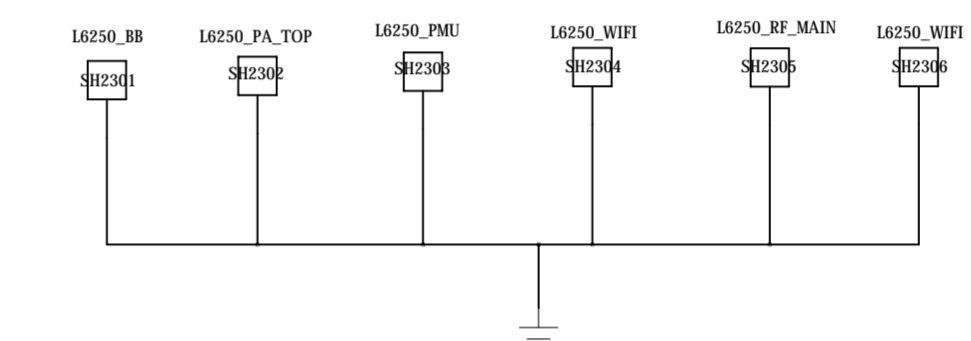
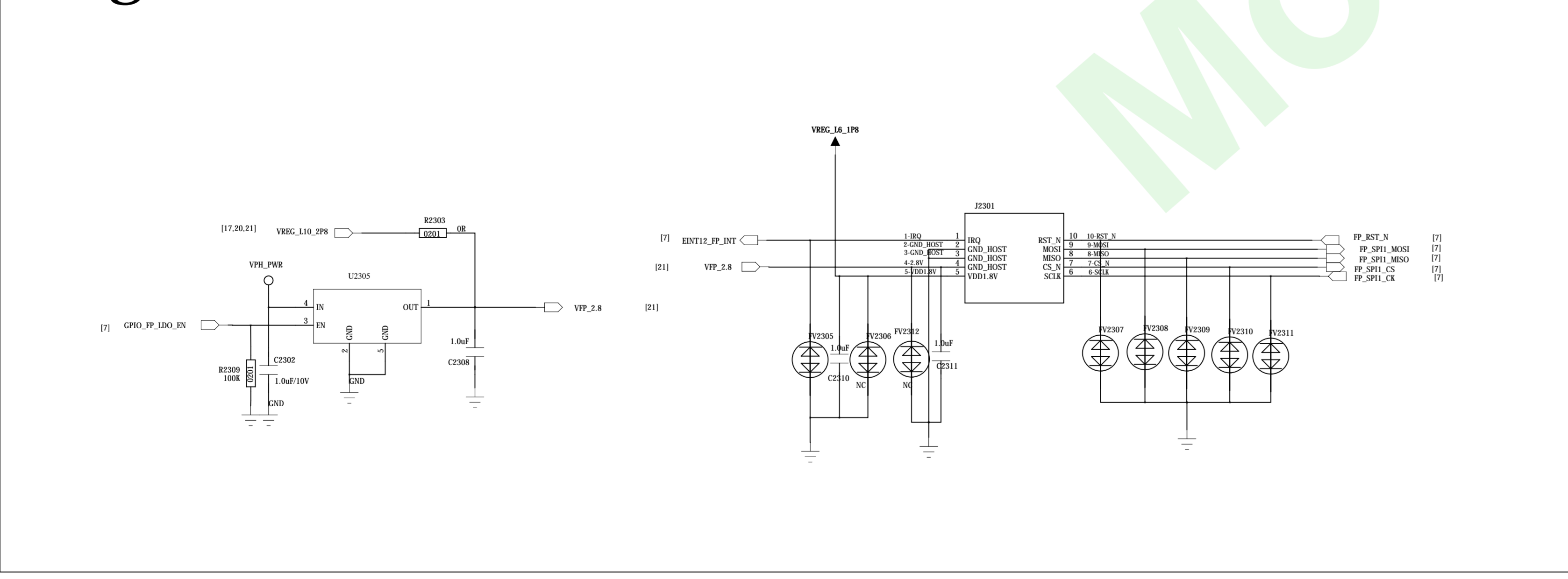

MARK POINT

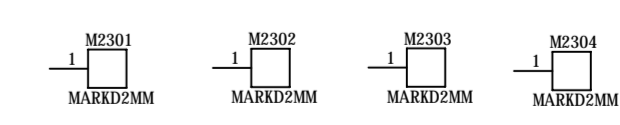

COMPANY: <Company Name>			
TITLE: <Title>			
DRAWN: <Drawn By>	DATE: <Drawn Date>	CODE	SIZE
CHECKED: <Checked By>	DATE: <Checked Date>	DRAWING NO.	REV.
QUALITY CONTROL: <QC By>	DATE: <QC Date>	<Code>	A0 <Drawing Number>Revision
RELEASED: <Released By>	DATE: <Release Date>	SCALE: <Scale>	SHEET: 24 31

Sub MIC

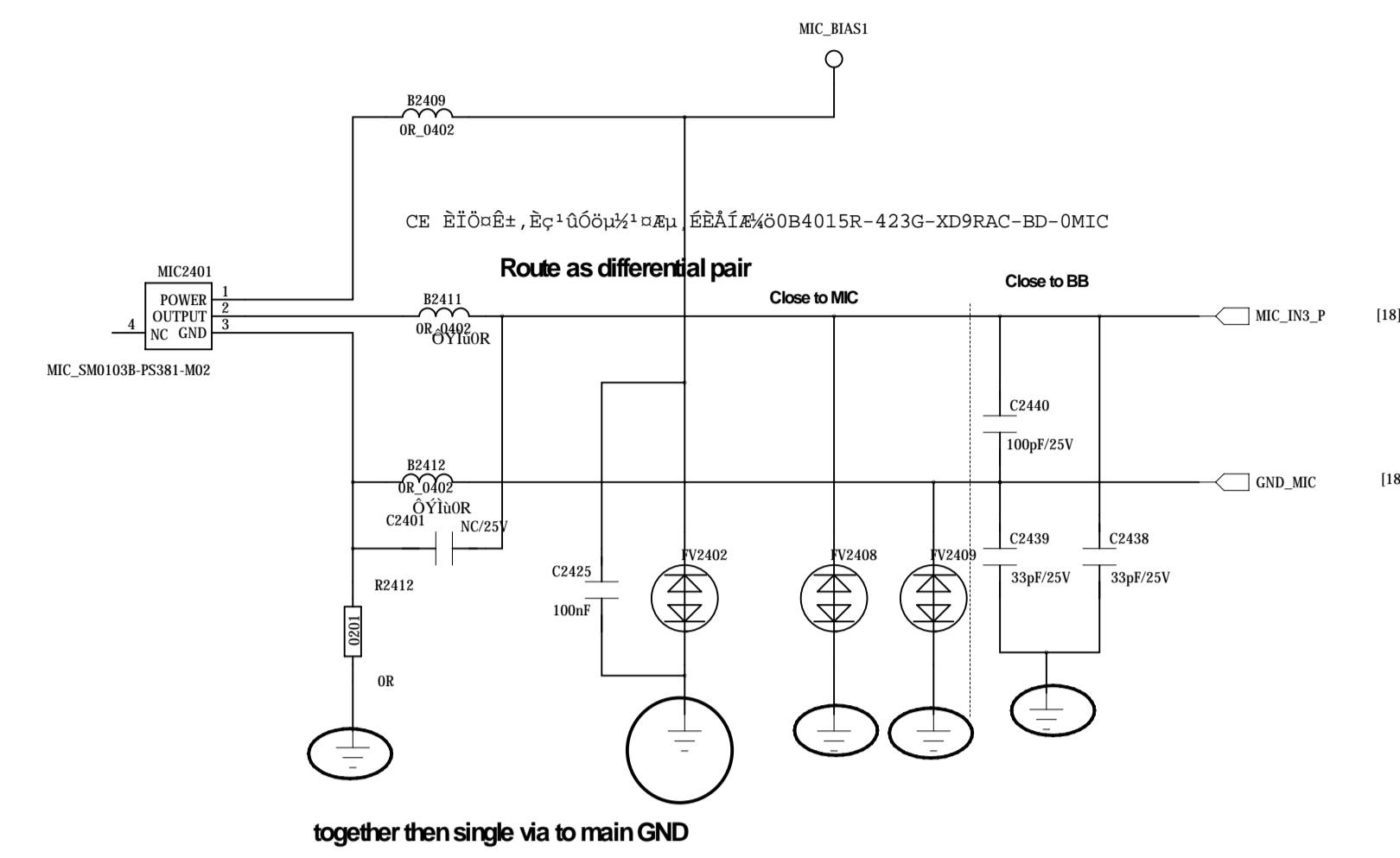

REC

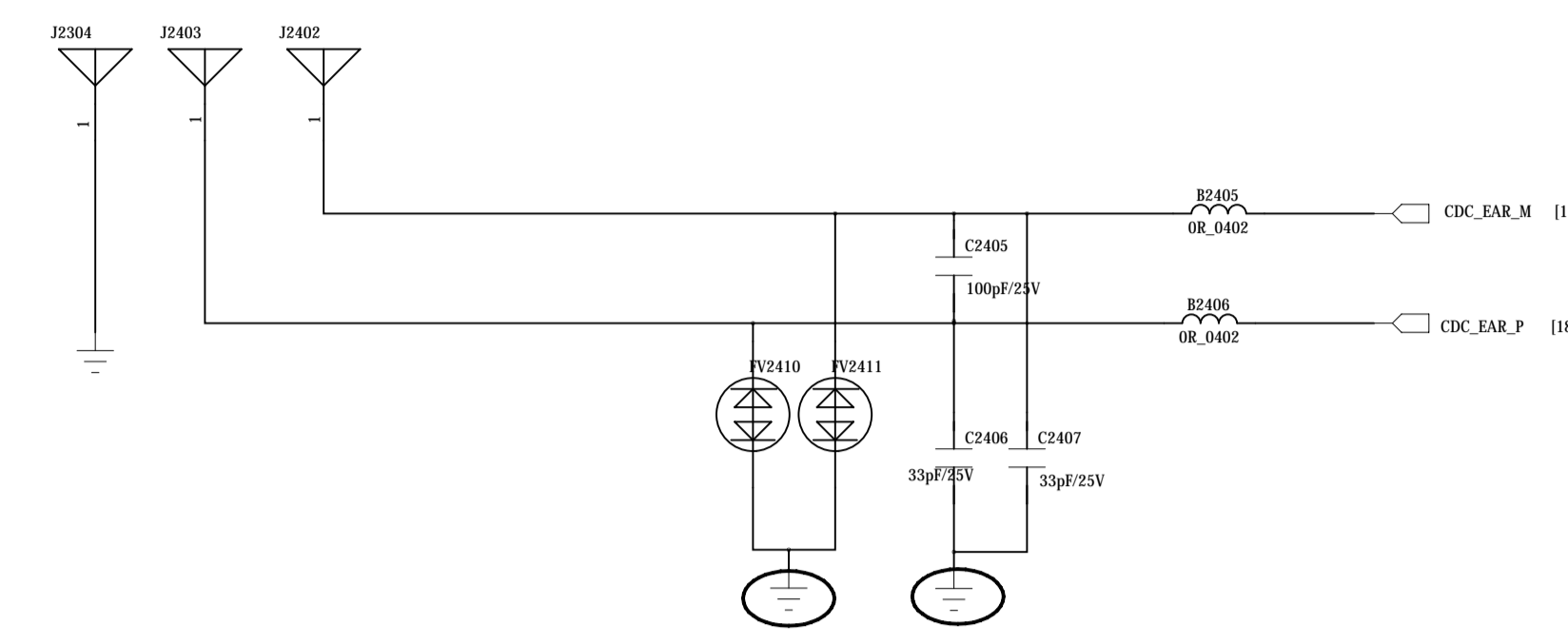

Audio PA

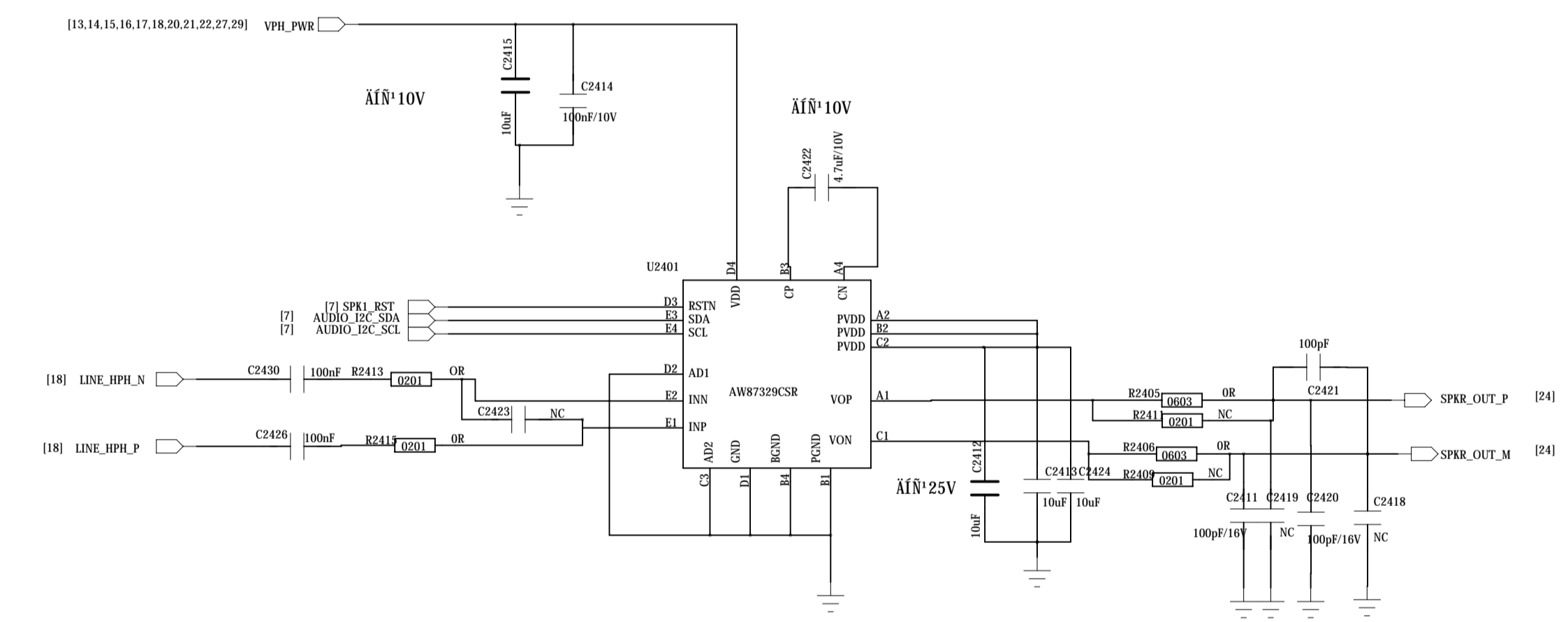

Earphone Audio

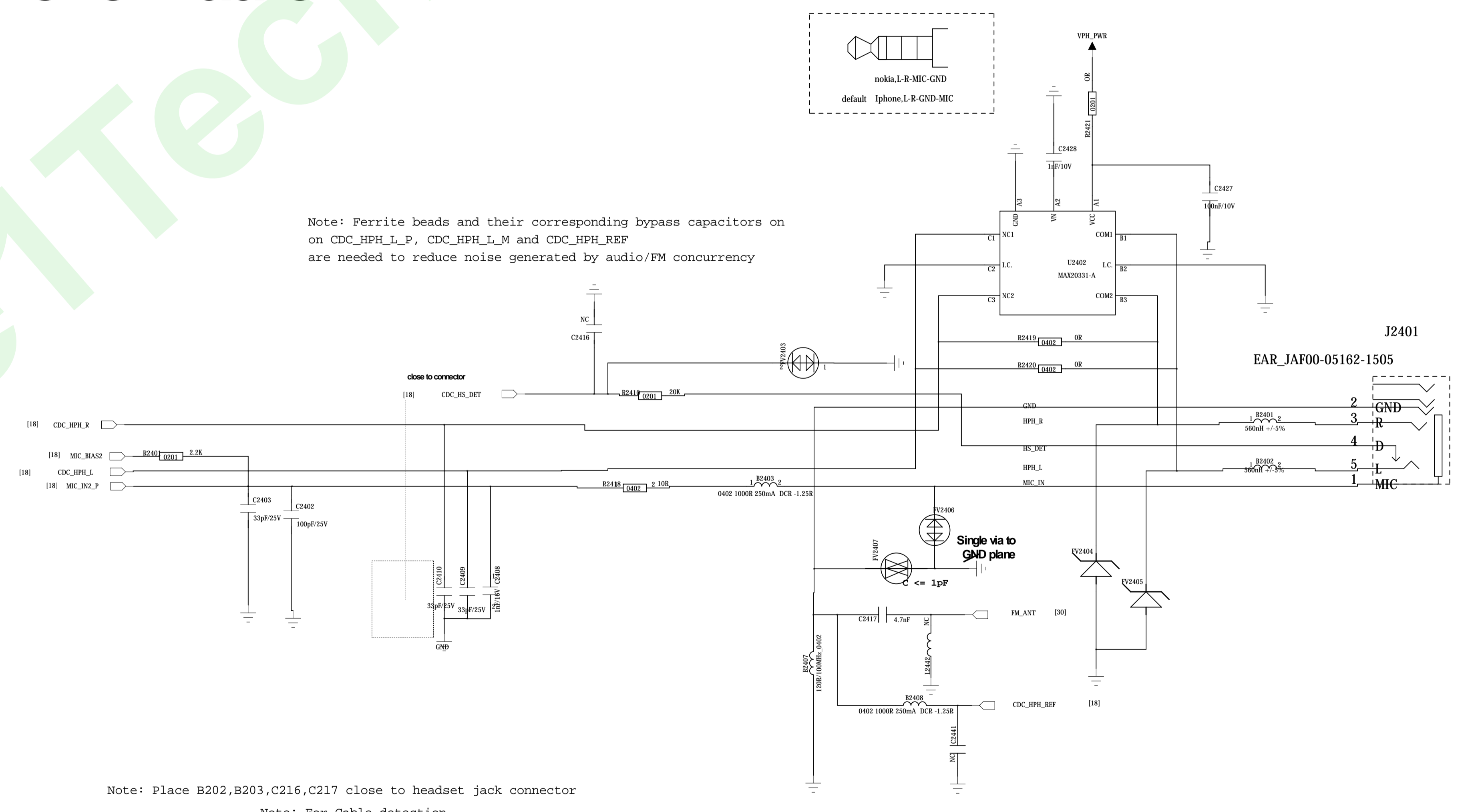

DRAWN: <Drawn By>		DATE: <Drawn Date>		CODE: <Code>		SIZE: A0		DRAWING NO: <Drawing Number>		REV: <Revision>	
CHECKED: <Checked By>		DATE: <Checked Date>		SCALE: <Scale>		SHEET: 22		31			
QUALITY CONTROL: <QC By>		DATE: <QC Date>									
RELEASED: <Released By>		DATE: <Release Date>									

T-Card

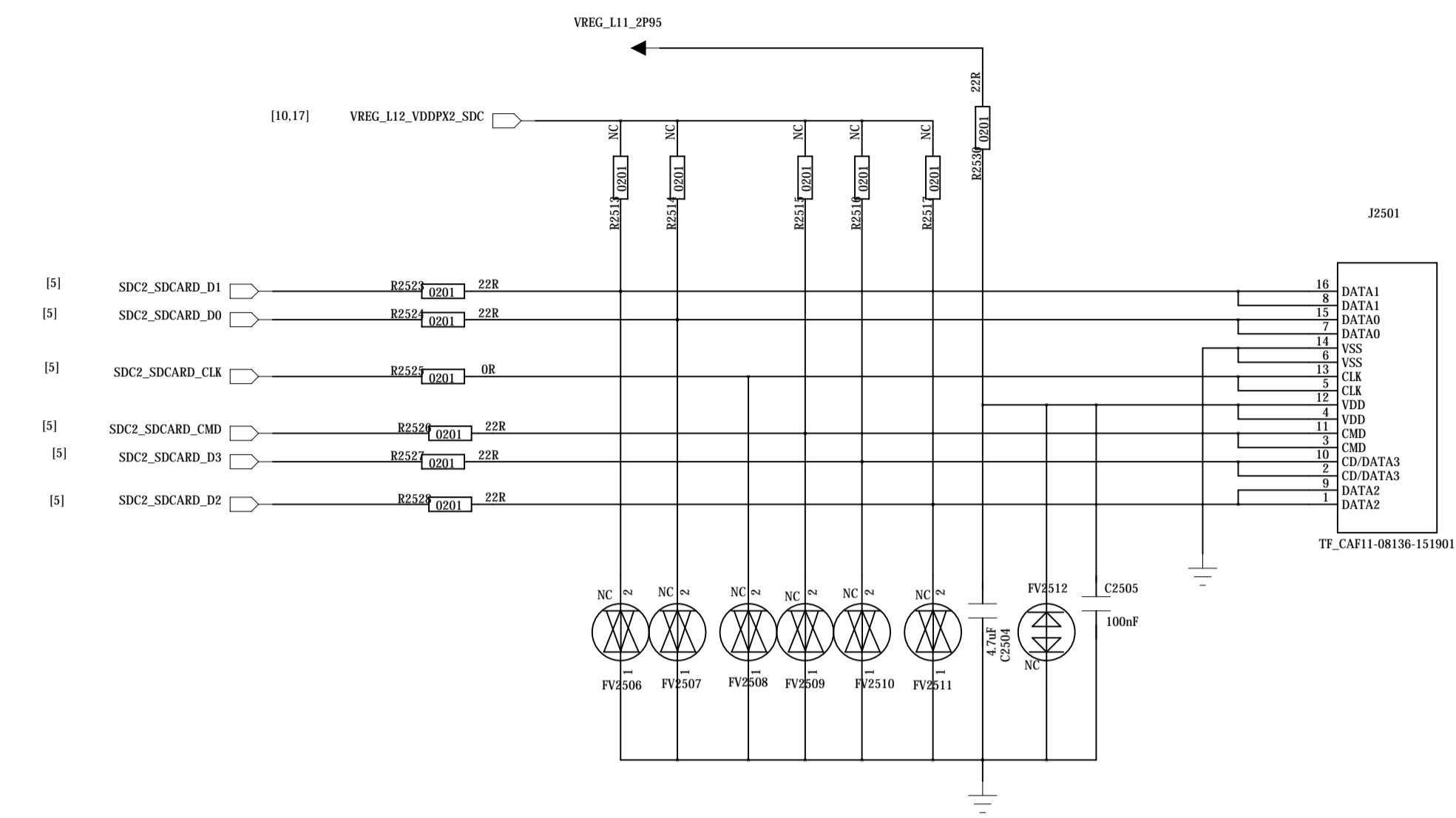

SIM1

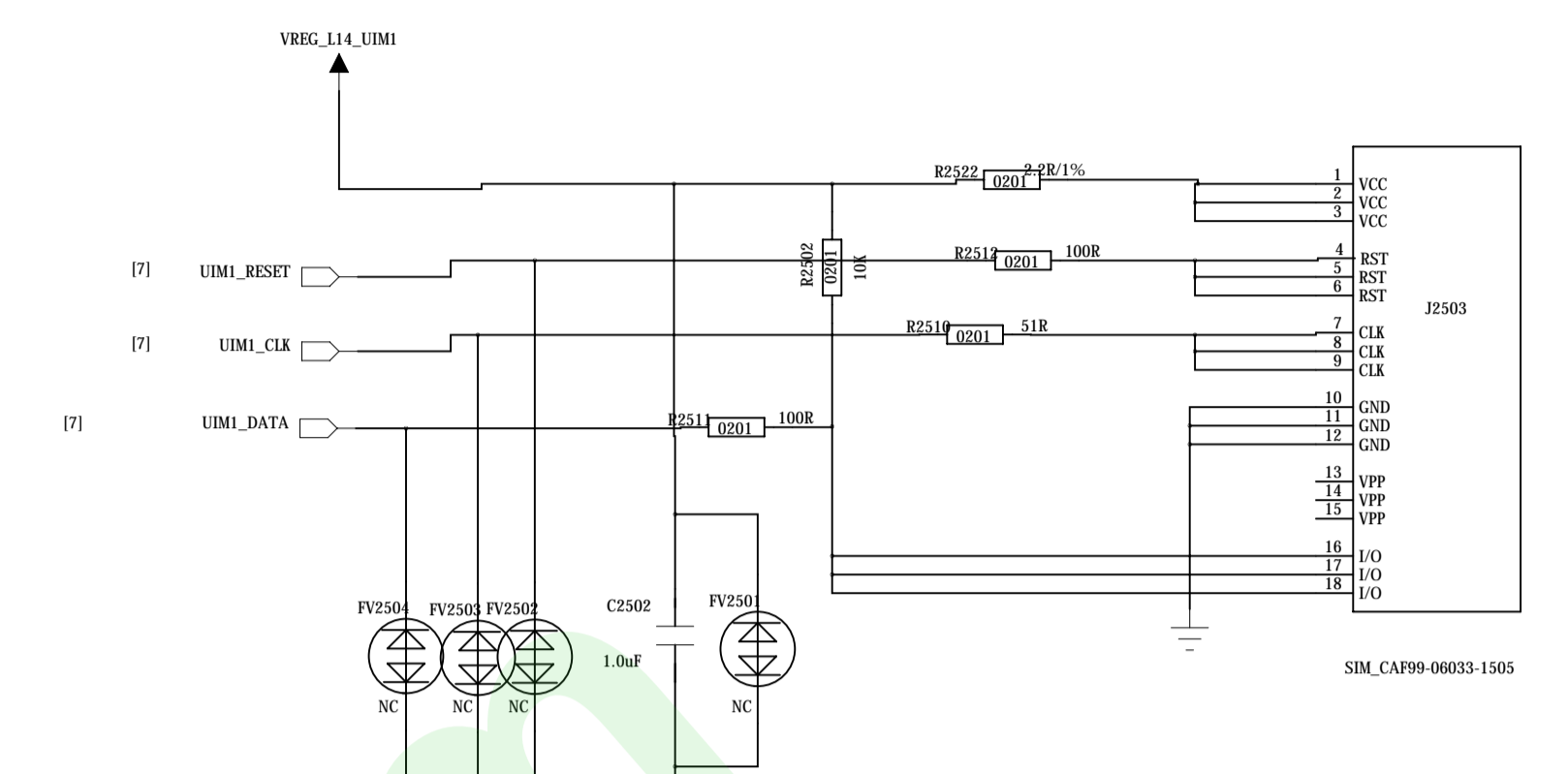

INT

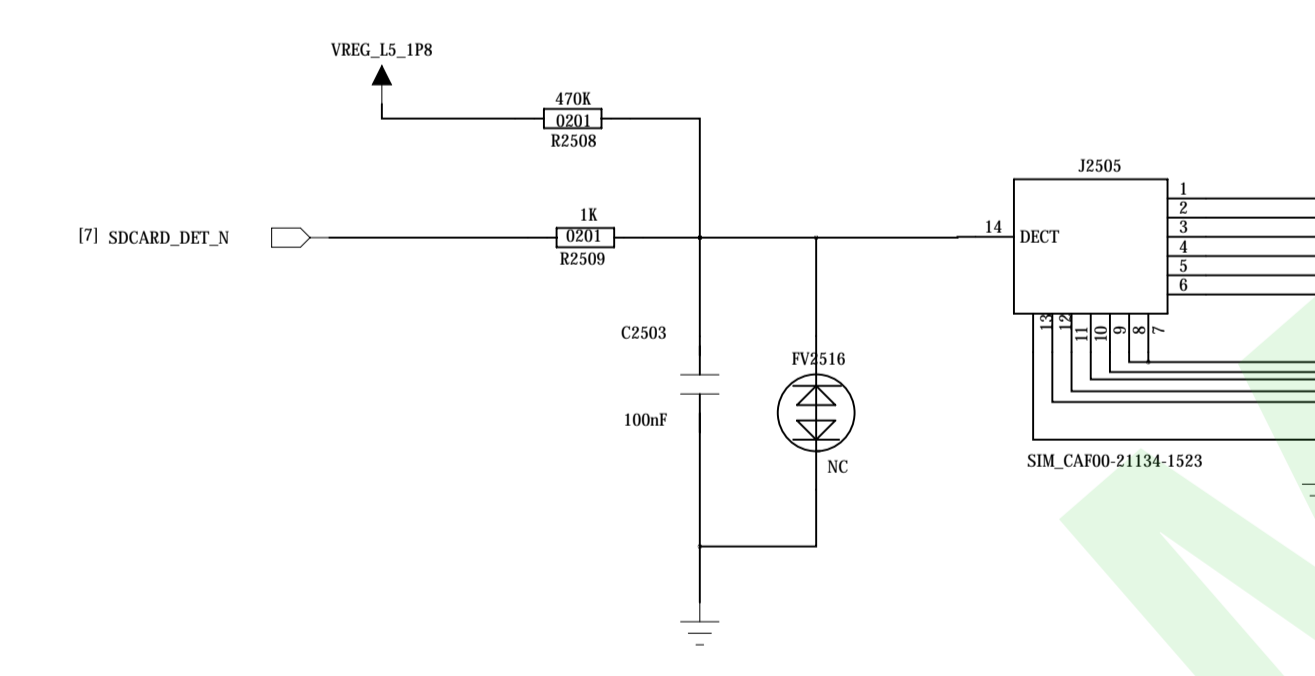

SIM2

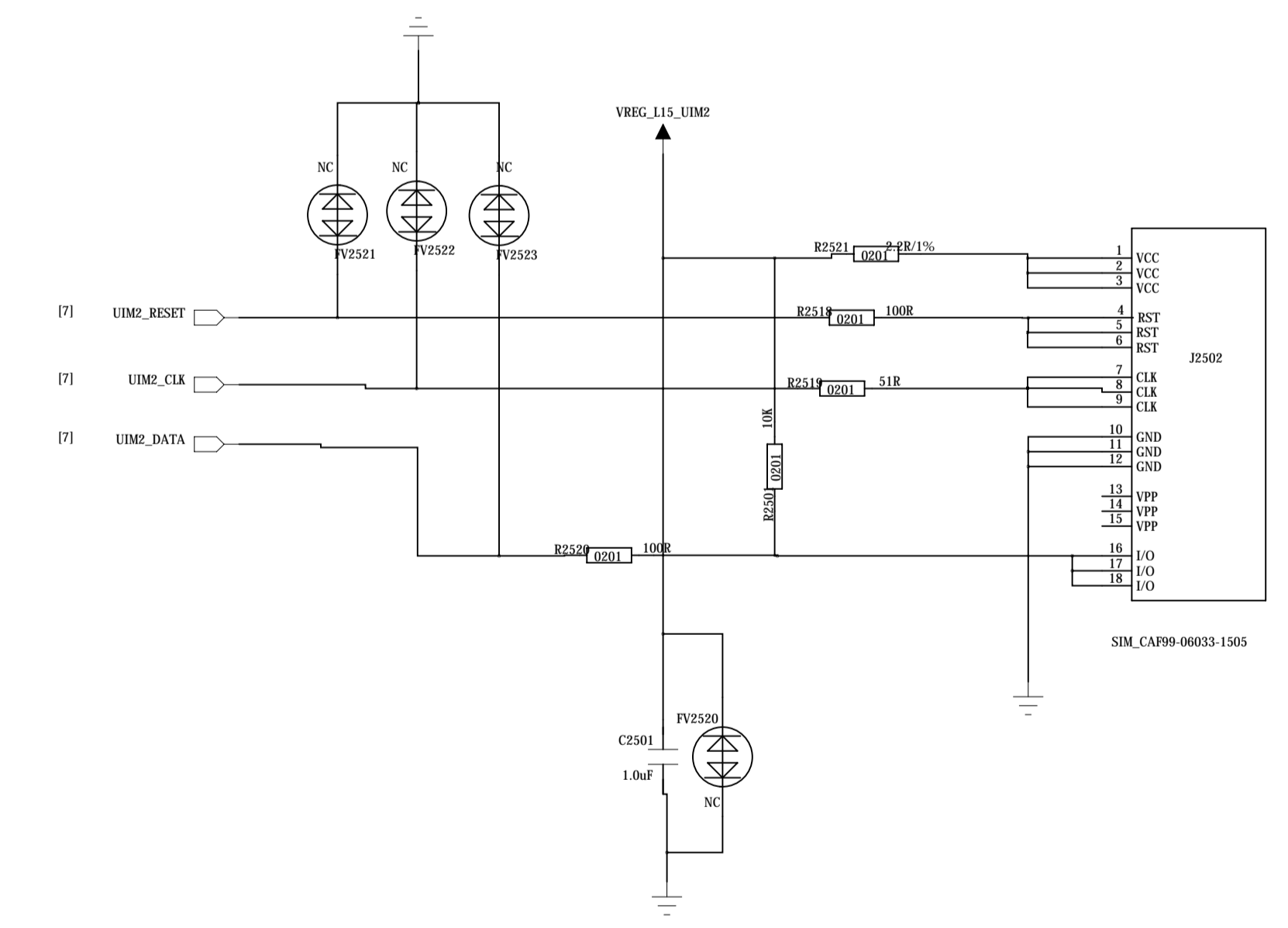

SUB_FPC

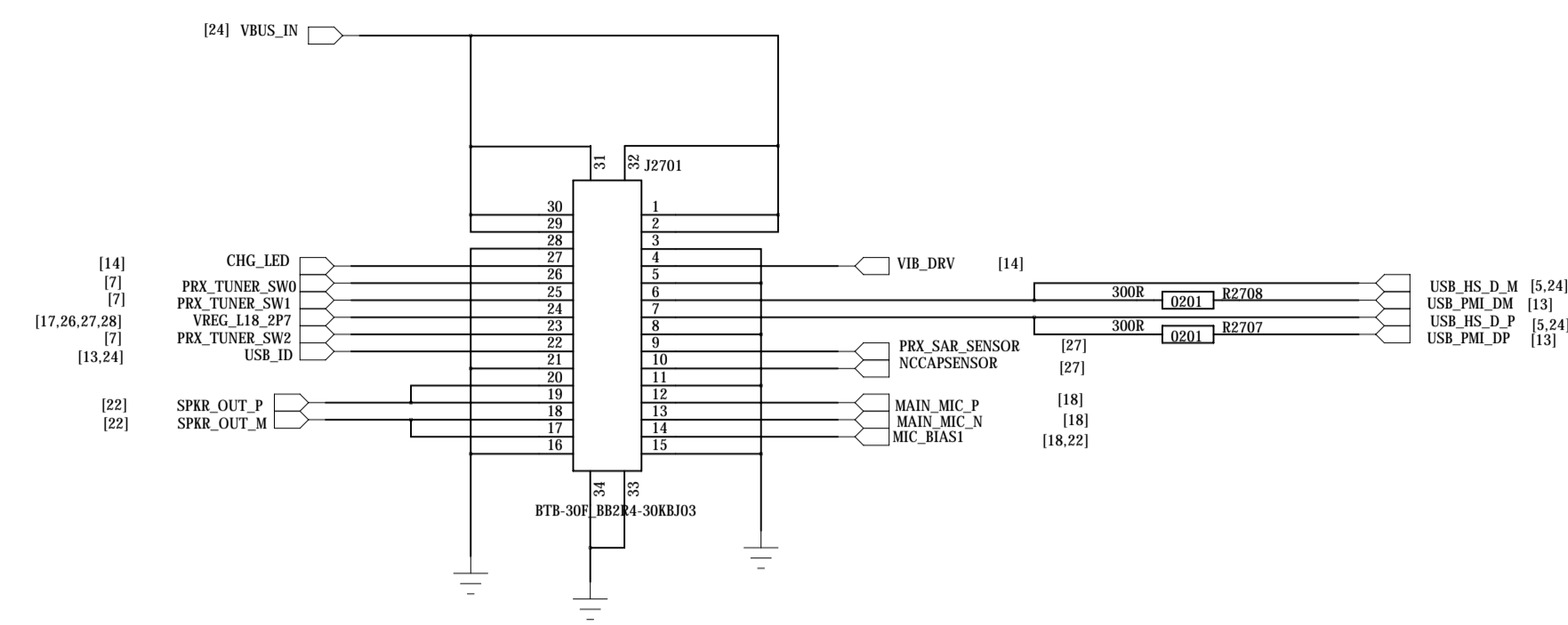

Power Key

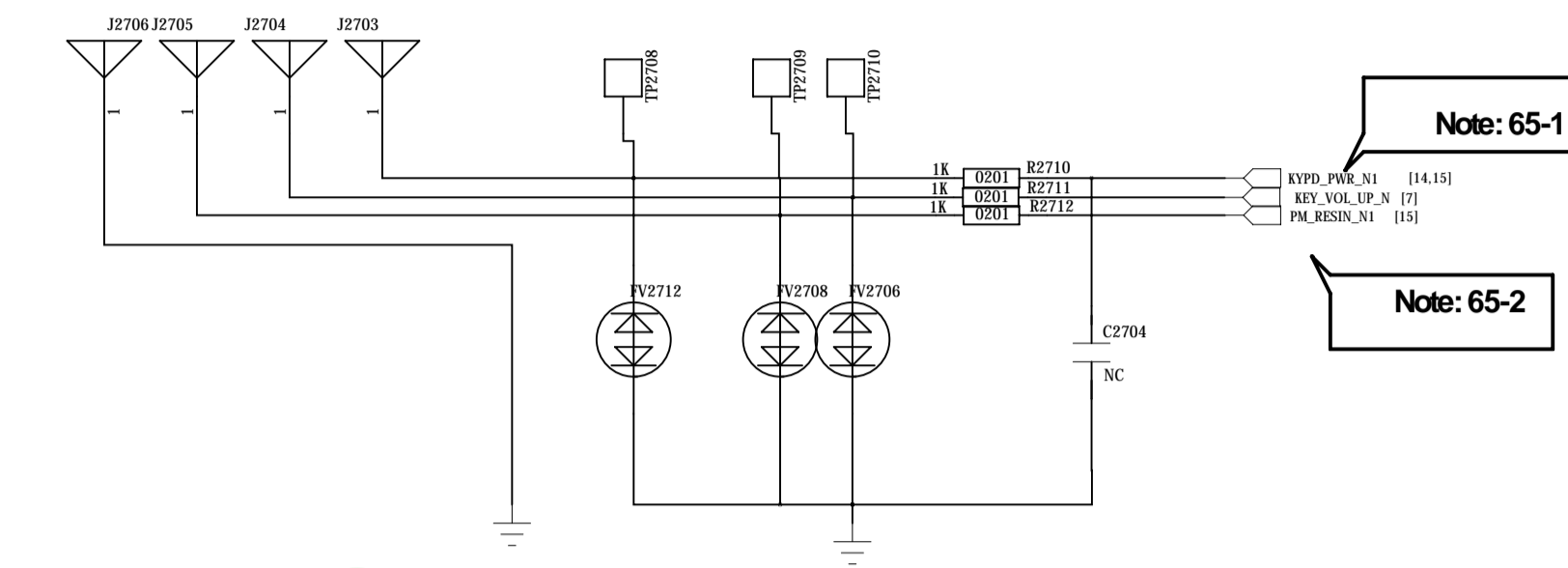

Schematic design notice of '65_PERI_Dual_SIM_ICUSB_KEYPAD' page.

Note 65-1: DO NOT put pull-up resistor on PWRKEY

Note 65-2: Volume Up : HOME key / GND
Volume Down : (RPROW0/KPCOLO) or KPCOLO / GND

Test point

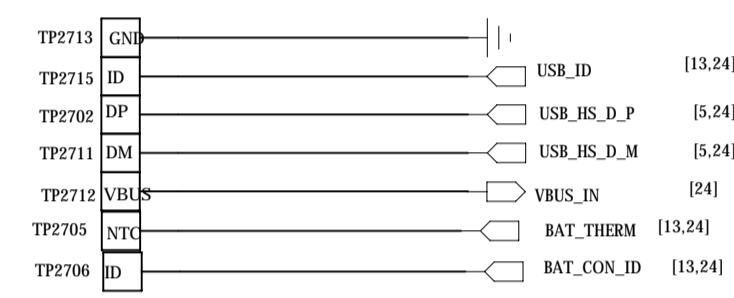

OVP

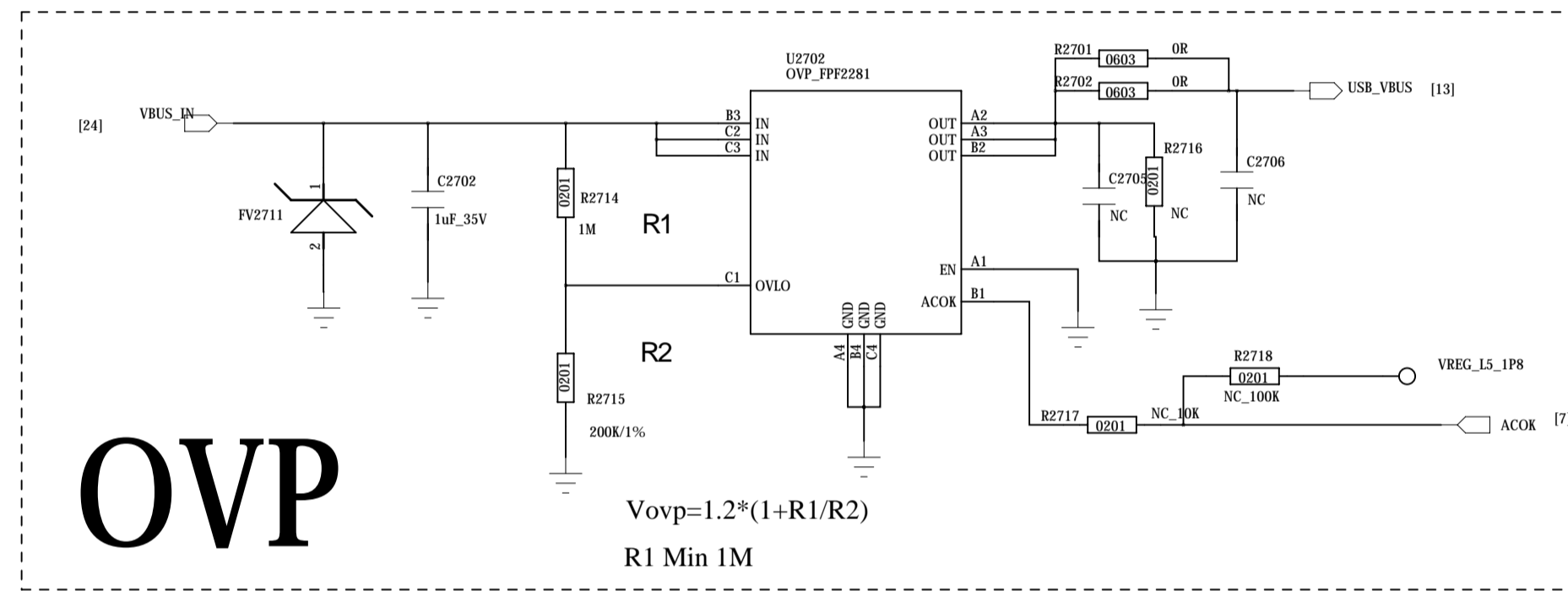

BAT

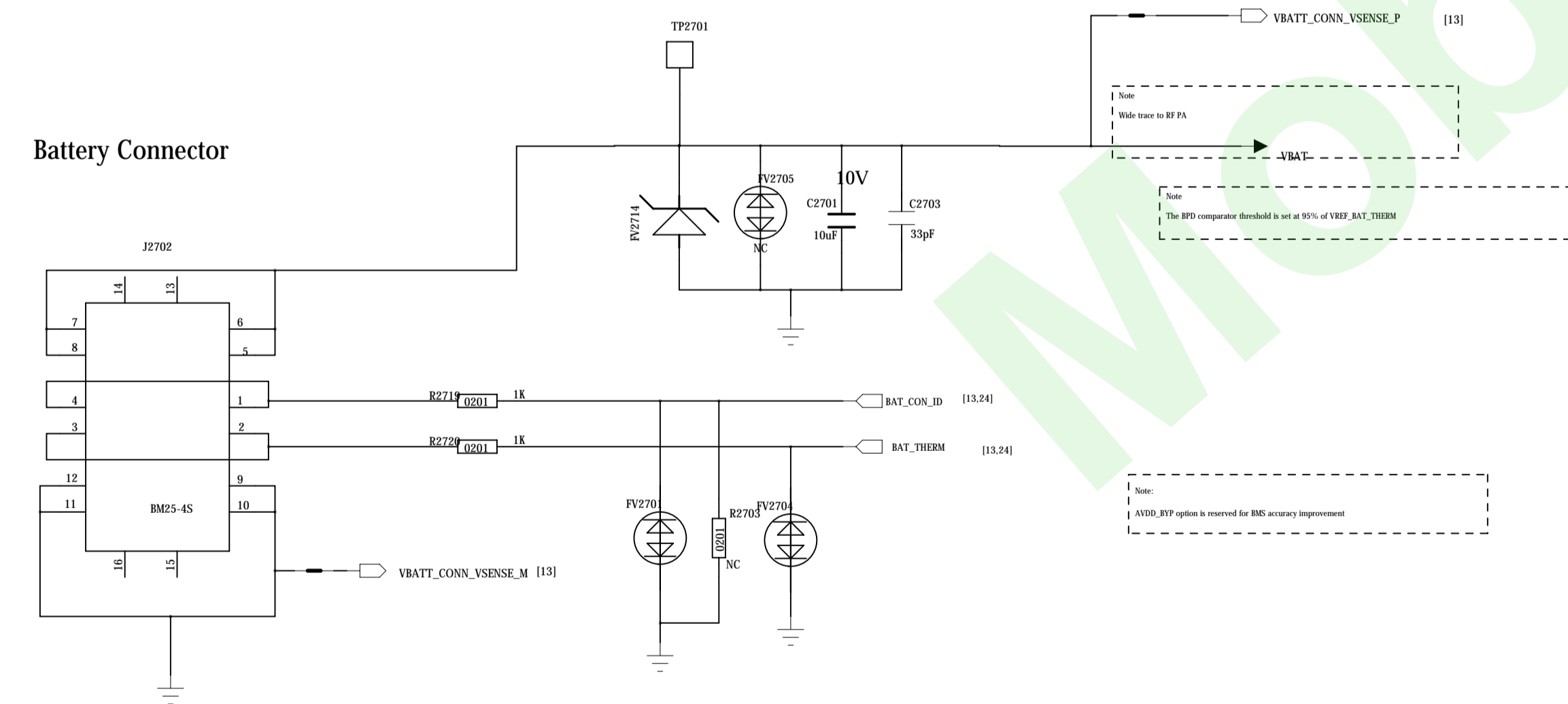

Note:
Battery ID resistor value require 20K-150K,
Add 100K to ground if battery package ID not meet requirement

Force USB boot

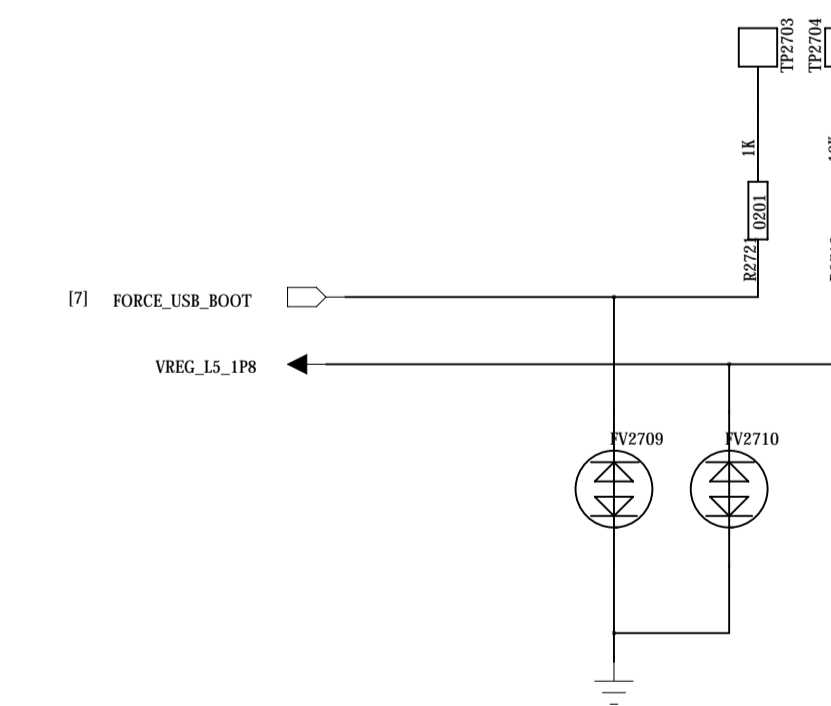

REVISION RECORD			
ITEM	REV NO.	APPROVED	DATE

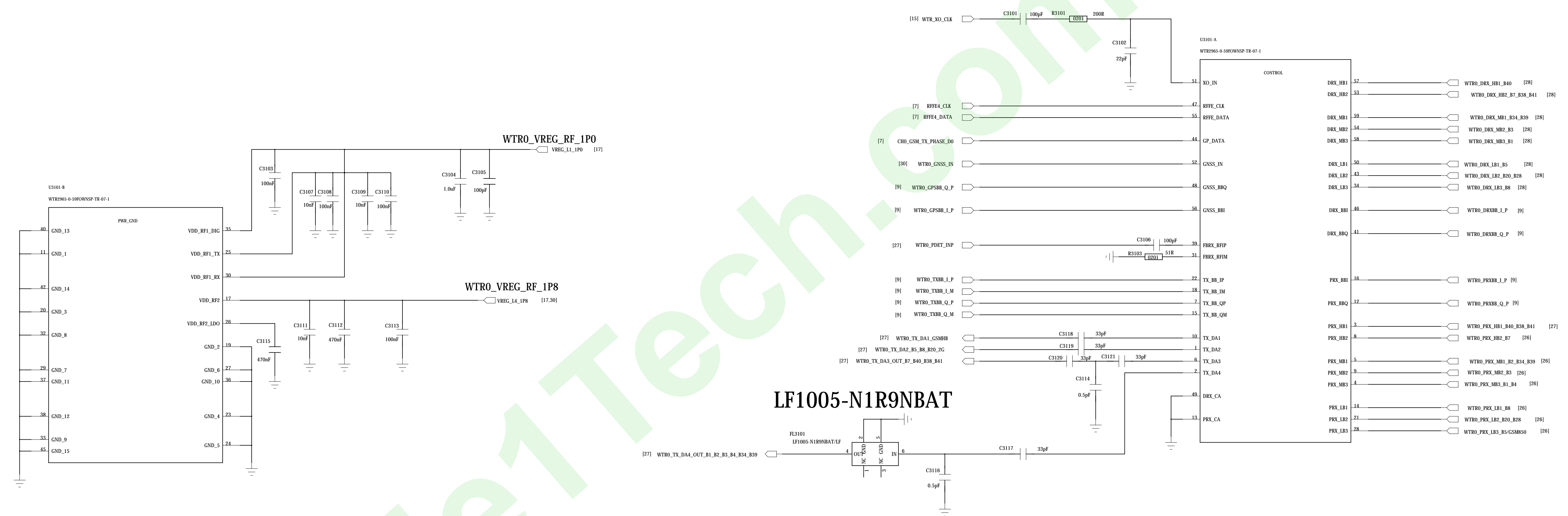

Note:RX ports have DC at the pin, so it need DC block, please make sure there is no DC short to other voltages and GND

DRAWN: <Drawn By>		DATED: <Drawn Date>		COMPANY: <Company Name>	
CHECKED: <Checked By>		DATED: <Checked Date>		TITLE: <Title>	
QUALITY CONTROL: <QC By>		DATED: <QC Date>		CODE: <Code>	SIZE: A0
RELEASED: <Released By>		DATED: <Release Date>		DRAWING NO: <Drawing Number> REV: <Revision>	
SCALE: <Scale>				SHEET: 86 31	

TRX_B1 TRX_B3

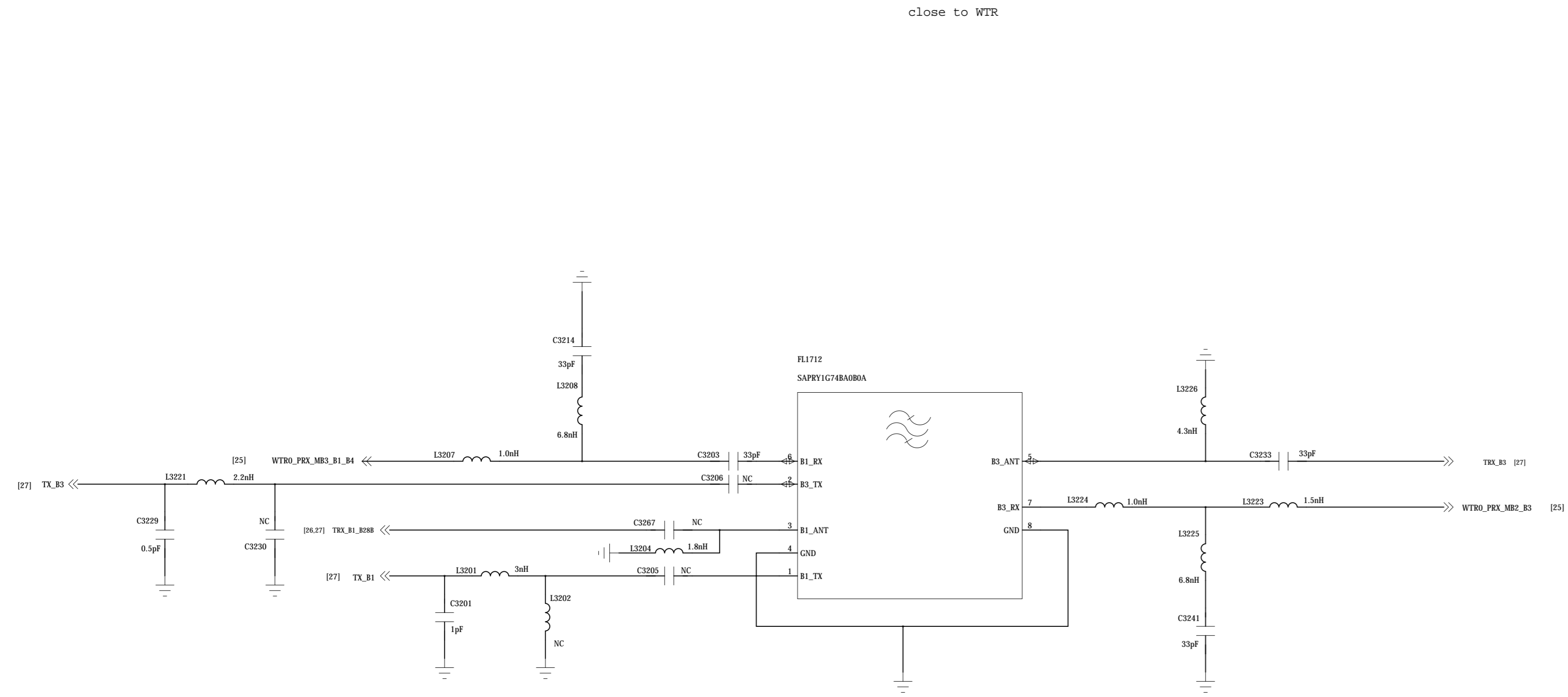

TRX_B7

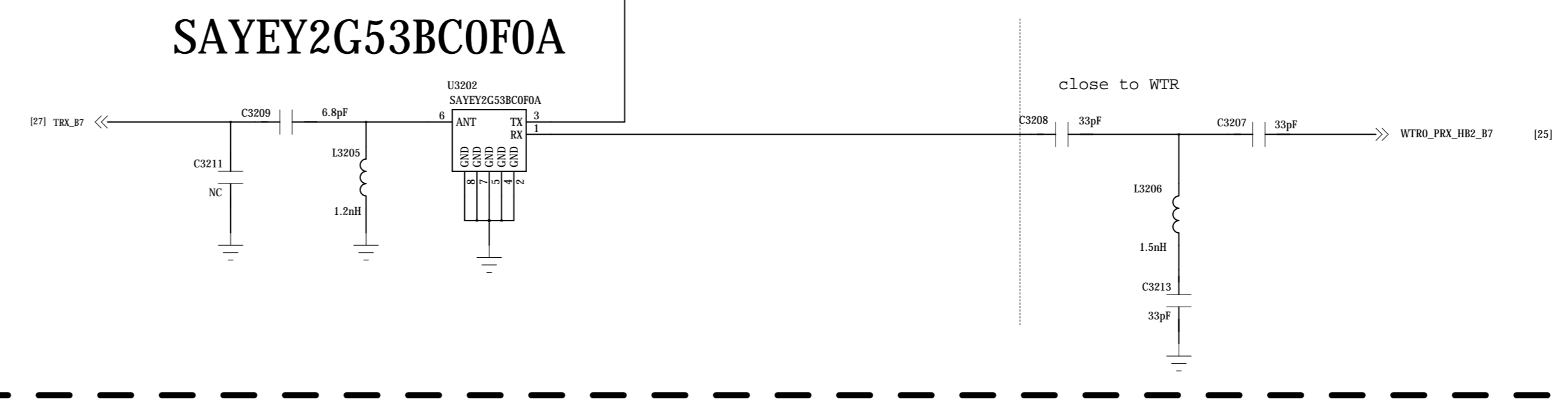

TRX_B8

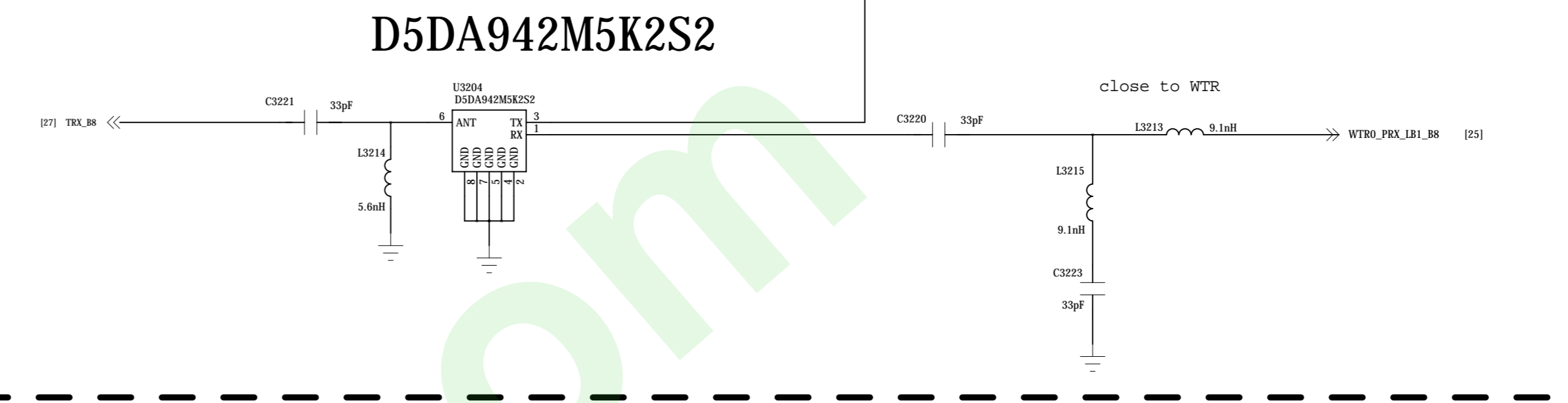

TRX_TDS_B34_B39

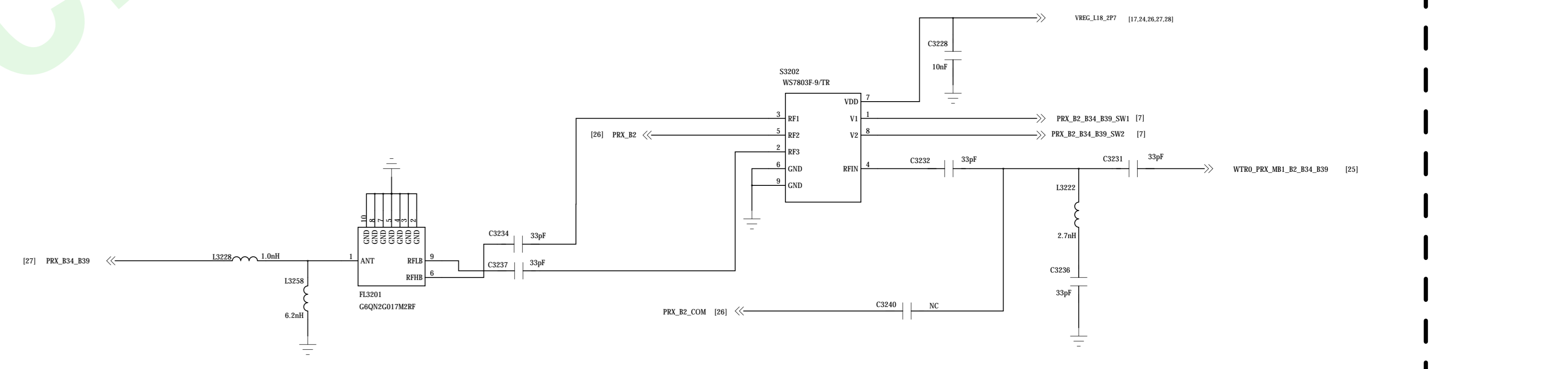

TRX_B2

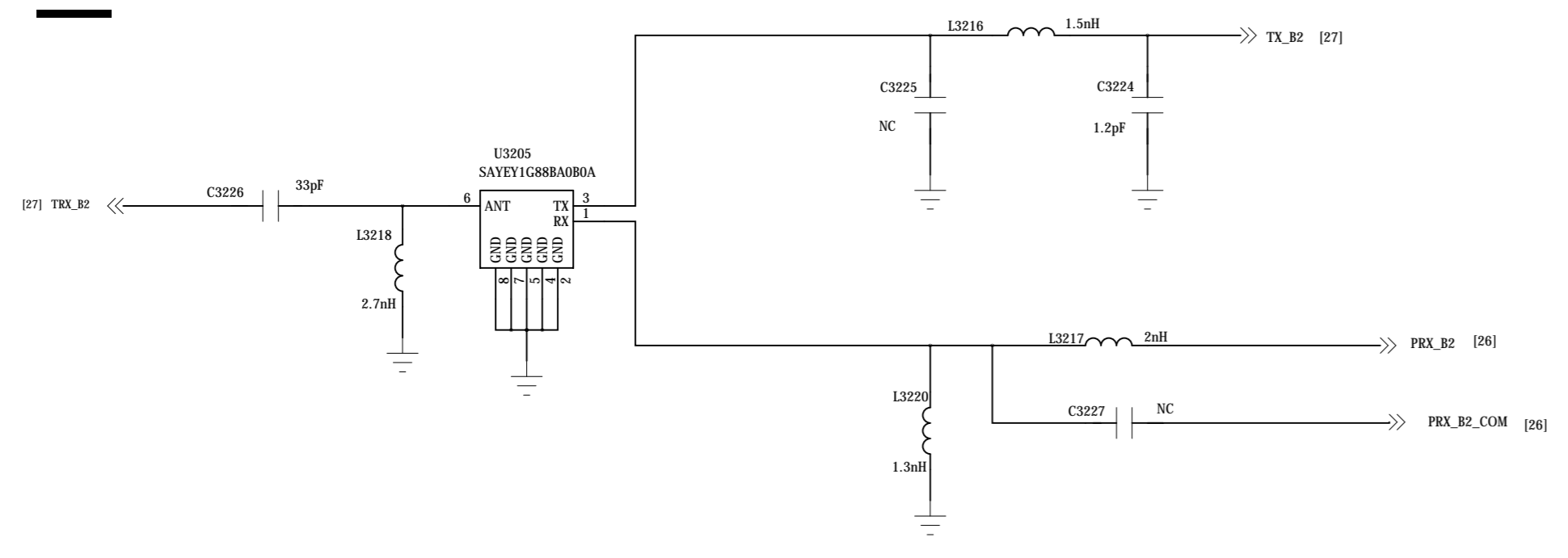

TRX_B5

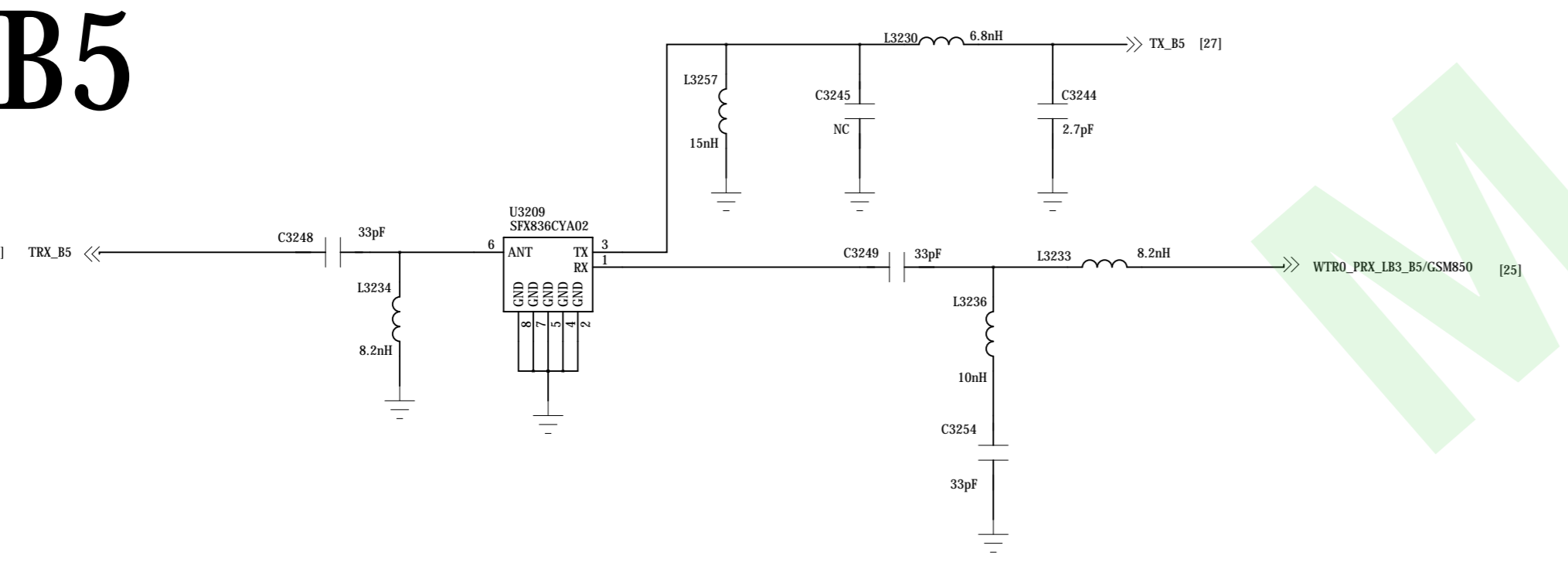

TRX_B20

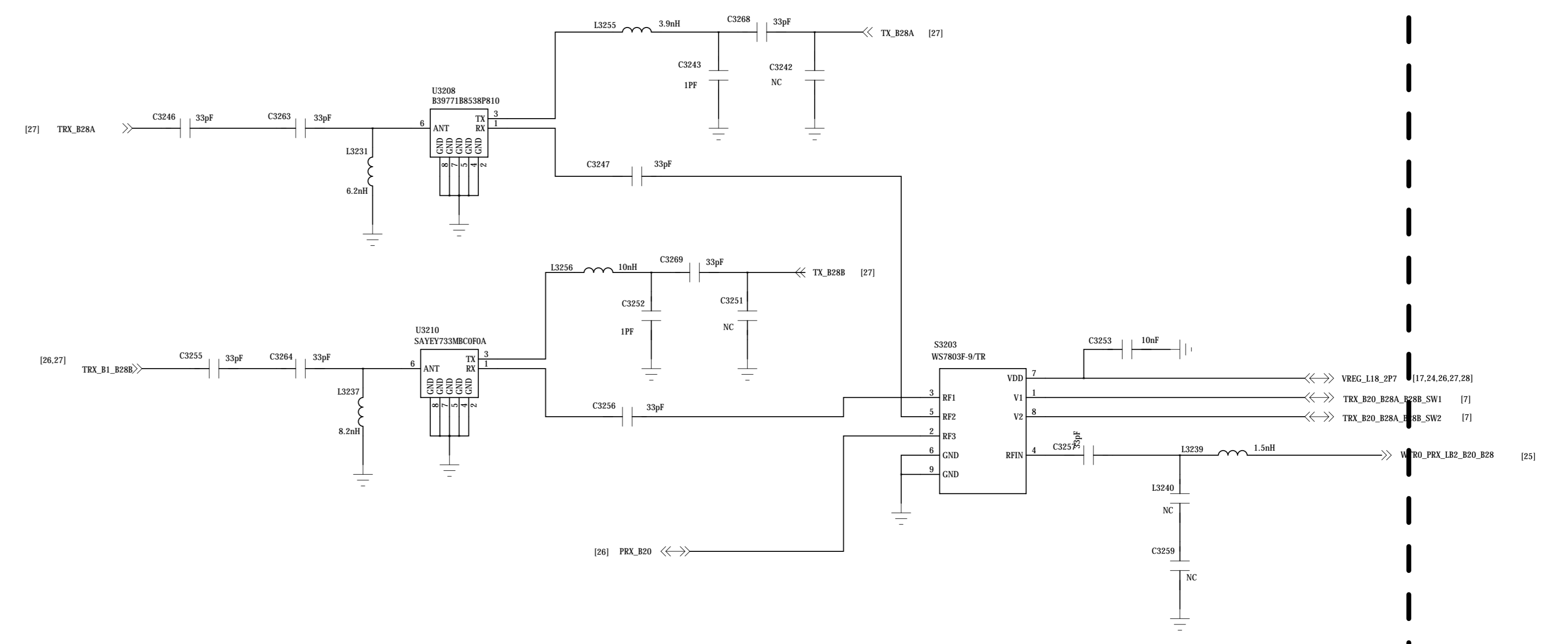
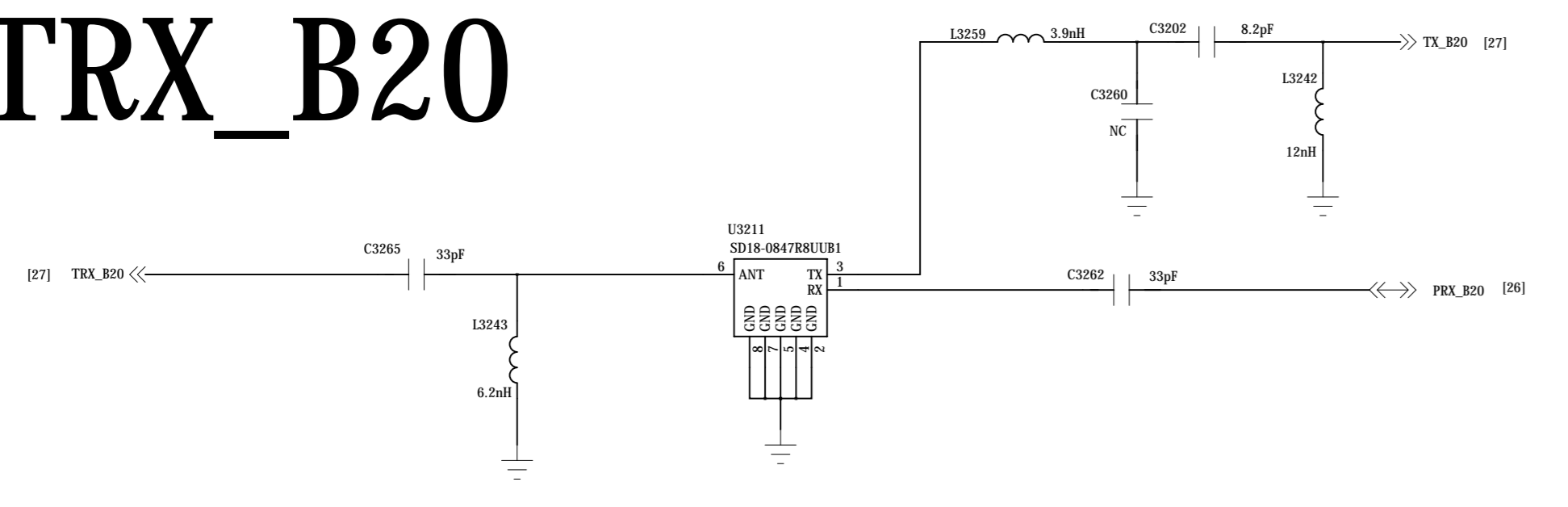

REVISION RECORD			
REV	REV NO	APPROVED	DATE

TXM

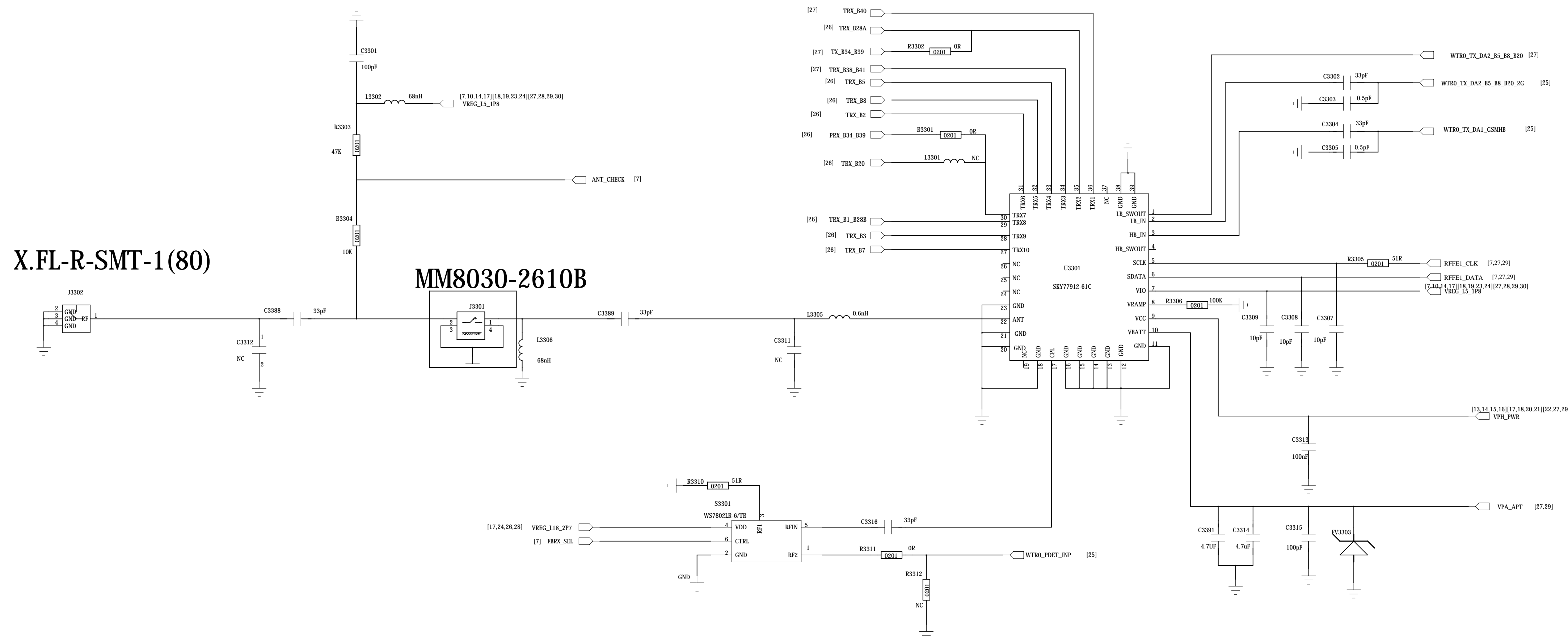

SAR Sensor

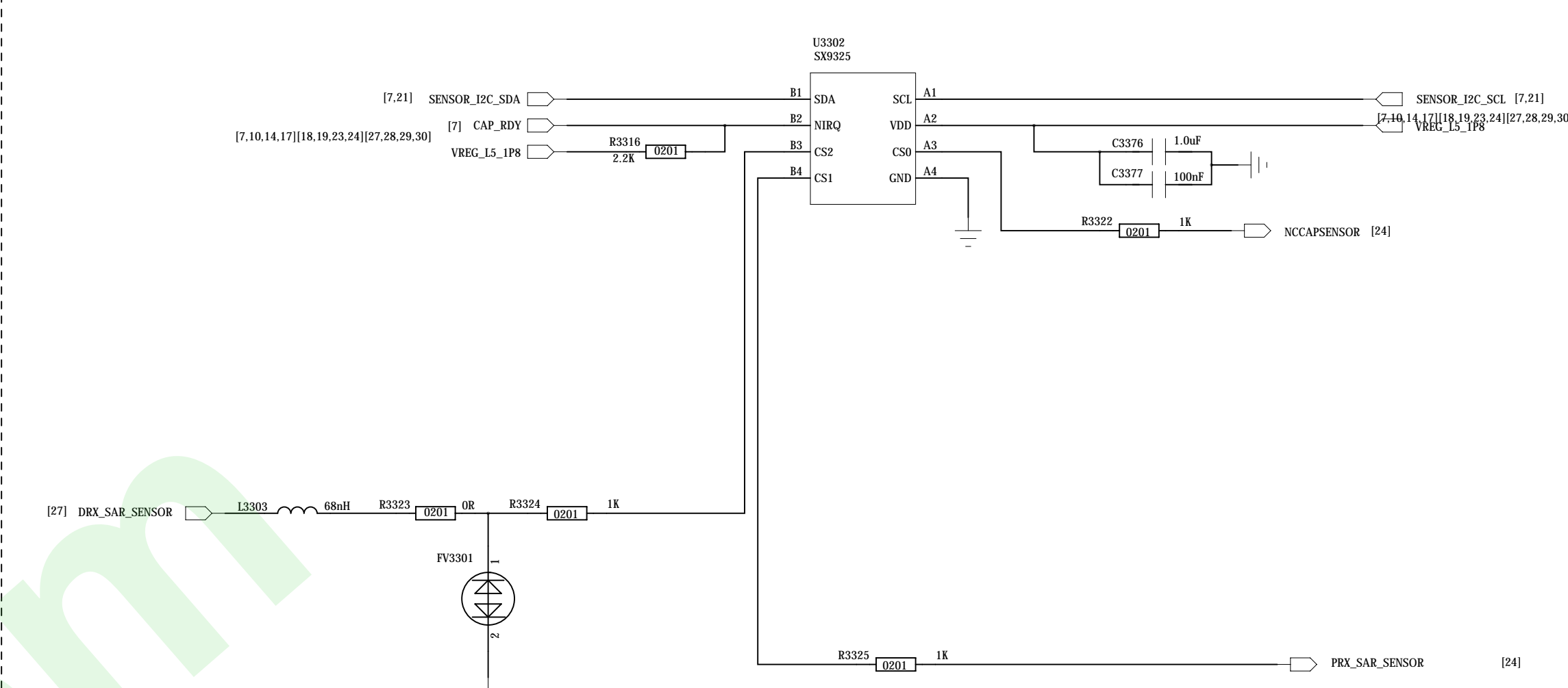

MMPA

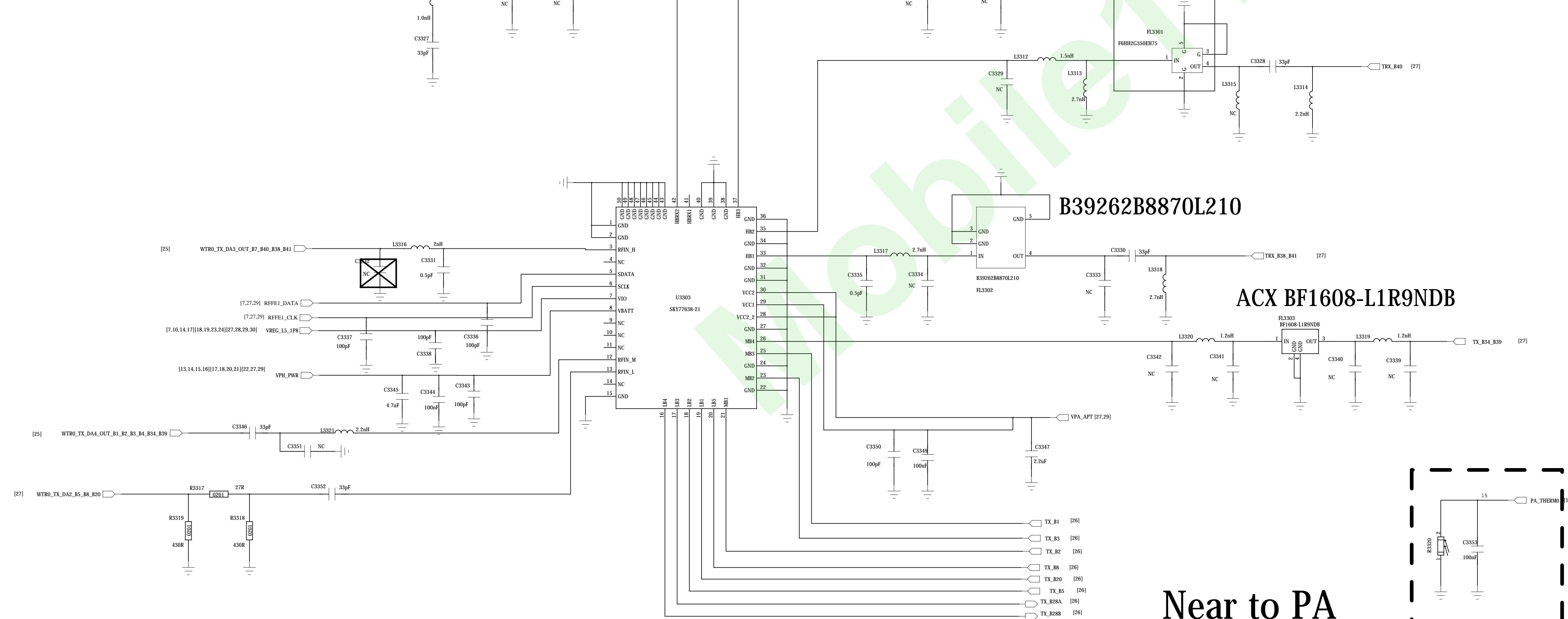

Near to PA

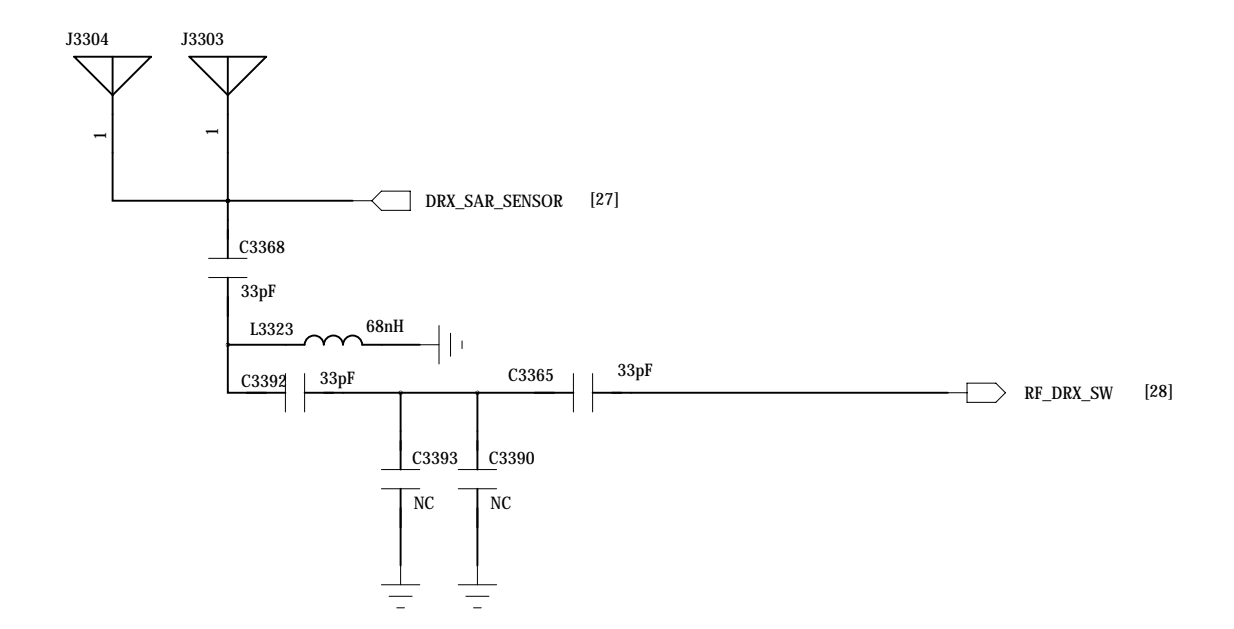

COMPANY: <Company Name>		TITLE: <Title>	
DESIGN: <Drawn By>	DATE: <Drawn Date>	CODE: <Code>	SIZE: A0
CHECKED: <Checked By>	DATE: <Checked Date>	DRAWING NO: <Drawing Number>	
QUALITY CONTROL: <QC By>	DATE: <QC Date>	REV: <Revision>	
RELEASED: <Released By>	DATE: <Release Date>	SCALE: <Scale>	SHEET: 2/ 31

ANT-Switch

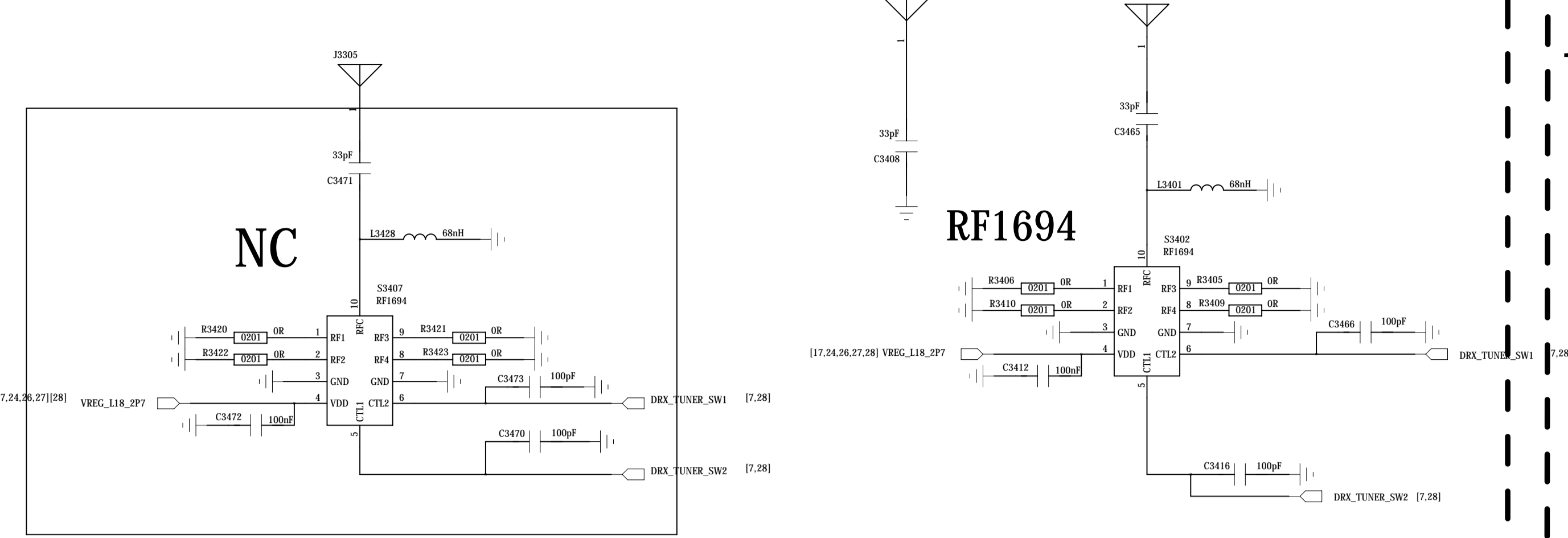

DRX

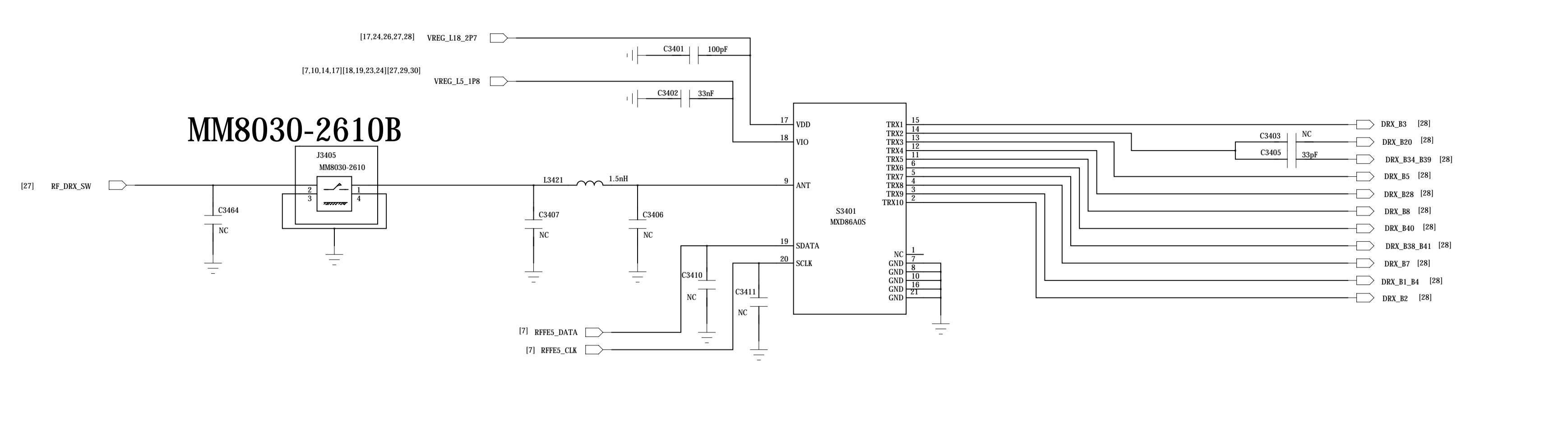

B1&B4_DRX

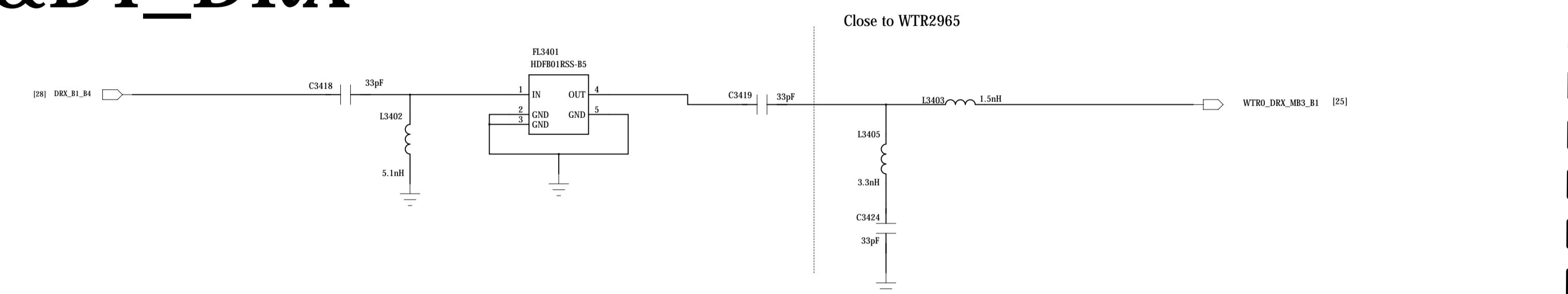

B3_DRX

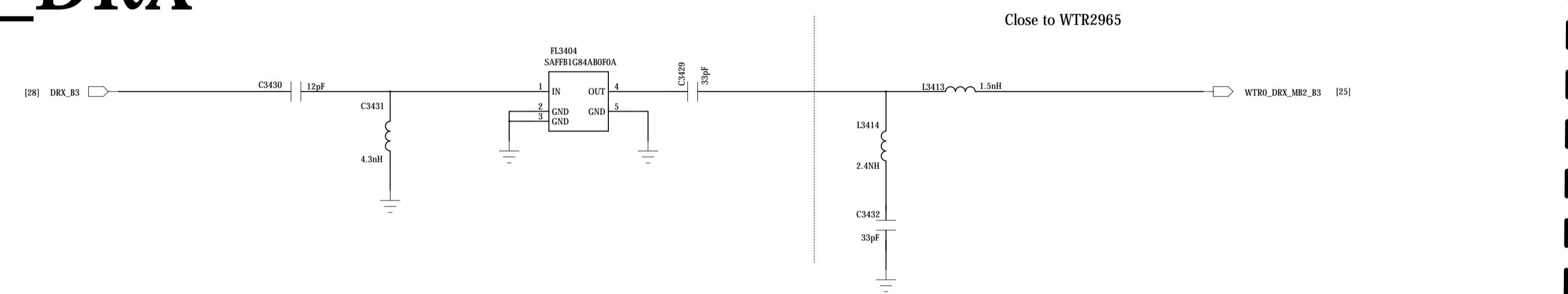

B5_DRX

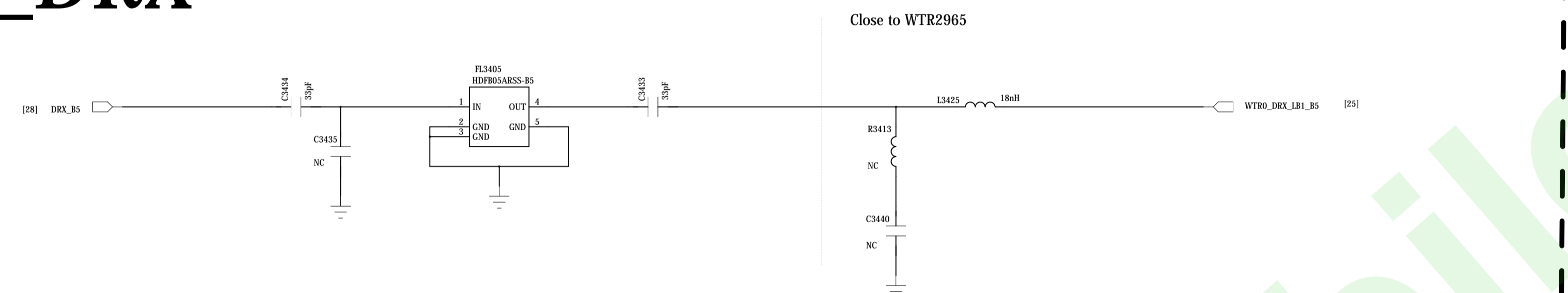

B8 DRX

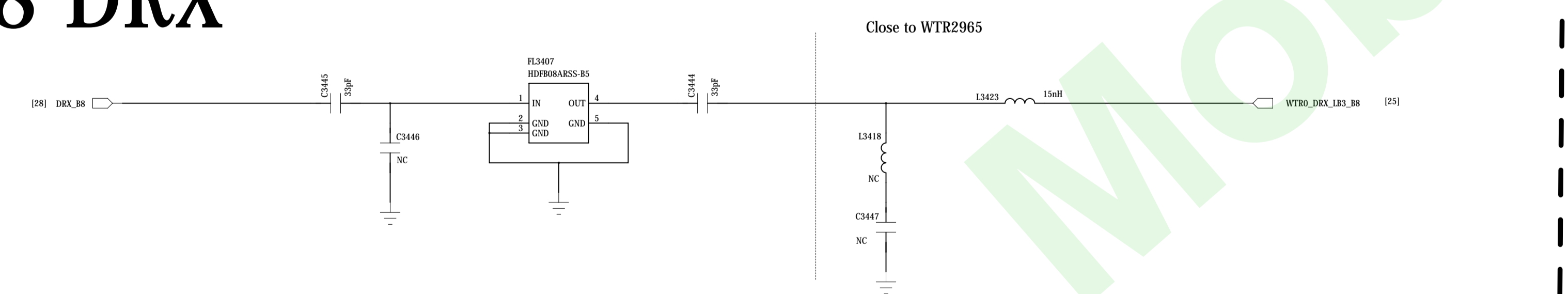

B40_DRX

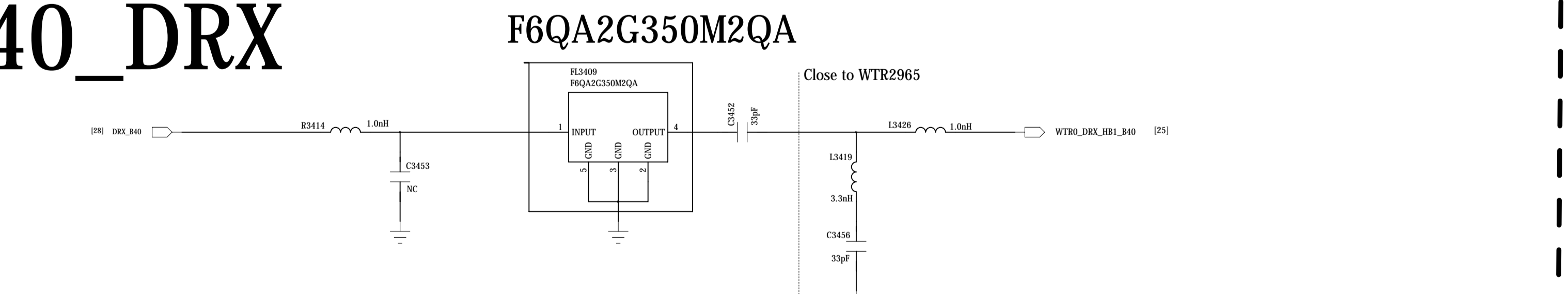

B7_B38_B41_DRX

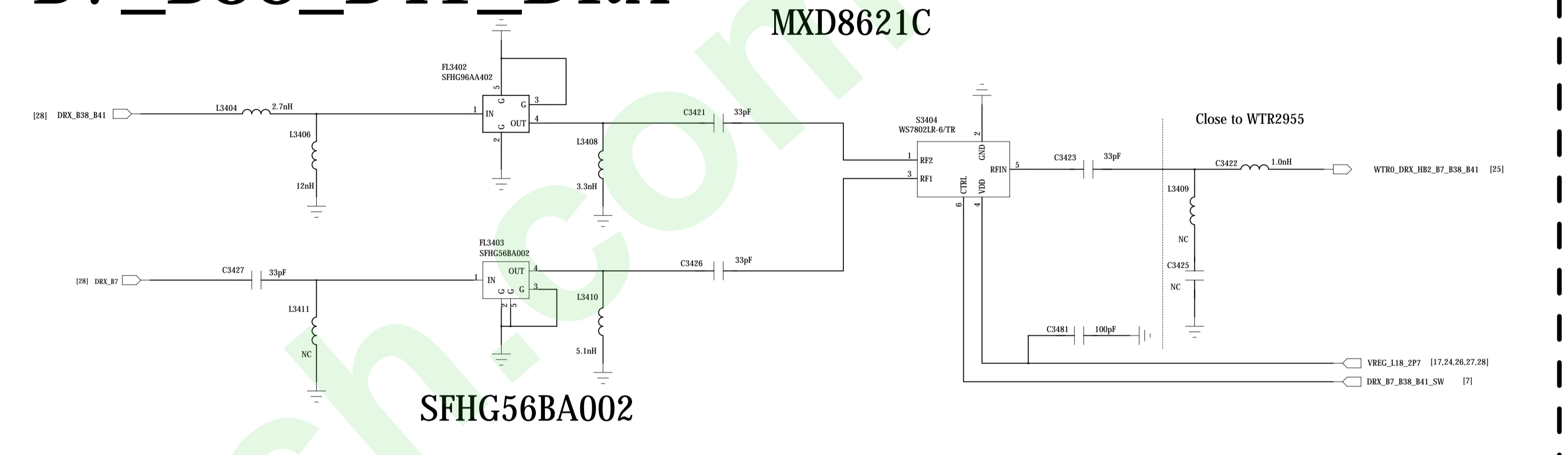

B34_B39_DRX

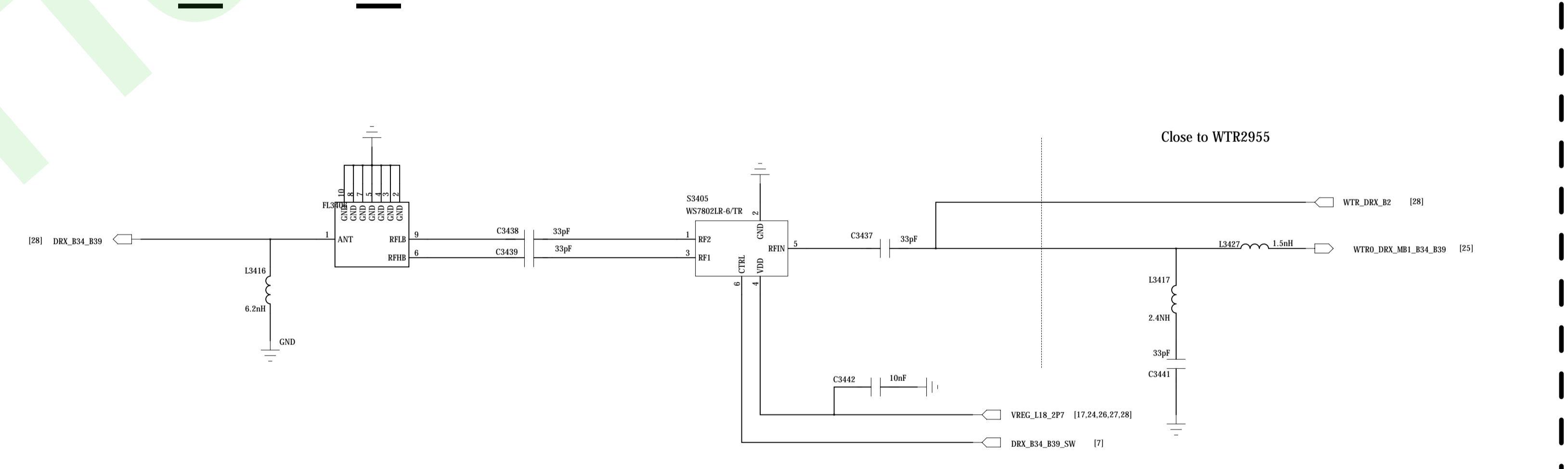

B2_B28_B20_DRX

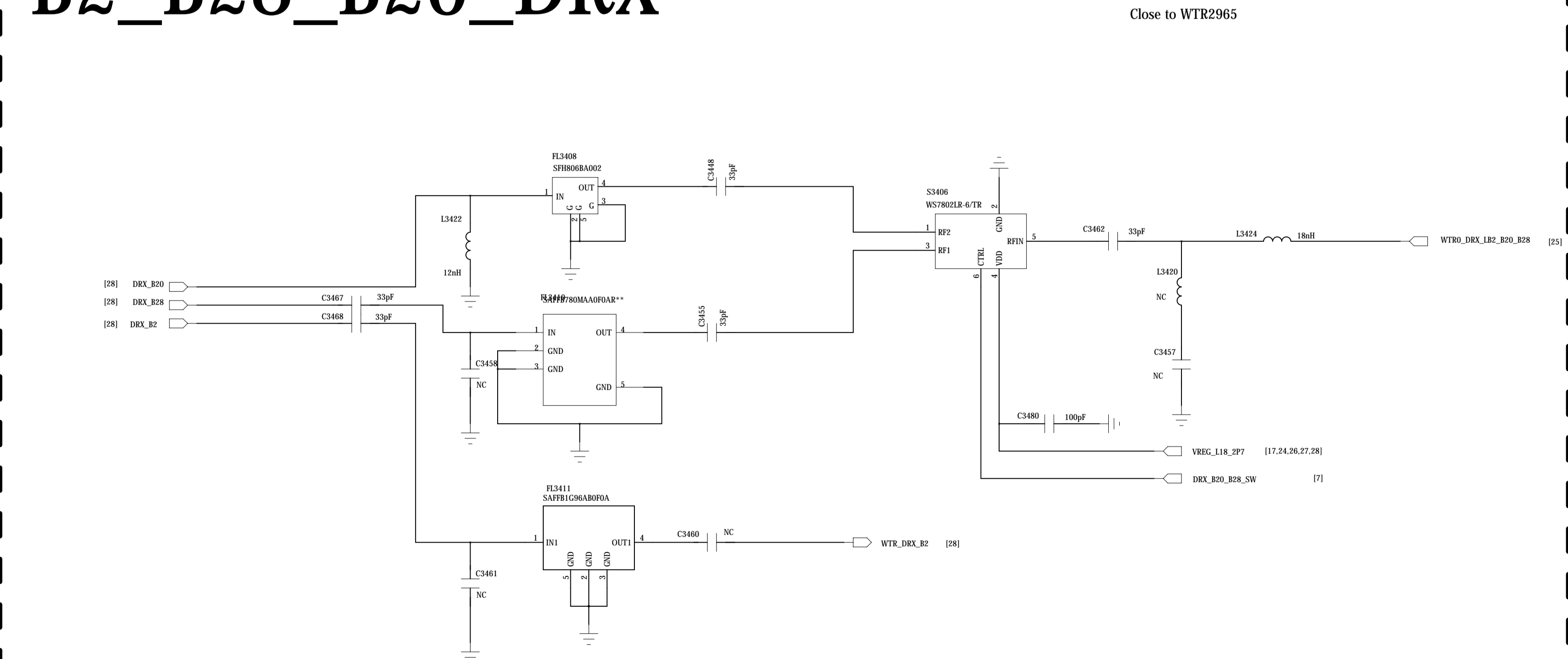

COMPANY: <Company Name>			
TITLE: 21_LTE_B7			
CODE: <Code>	SIZE: A0	DRAWING NO: <Drawing Number>	REV: <Revision>
DESIGN: LiuMengya	DRAWN: <Drawn Date>		

APT

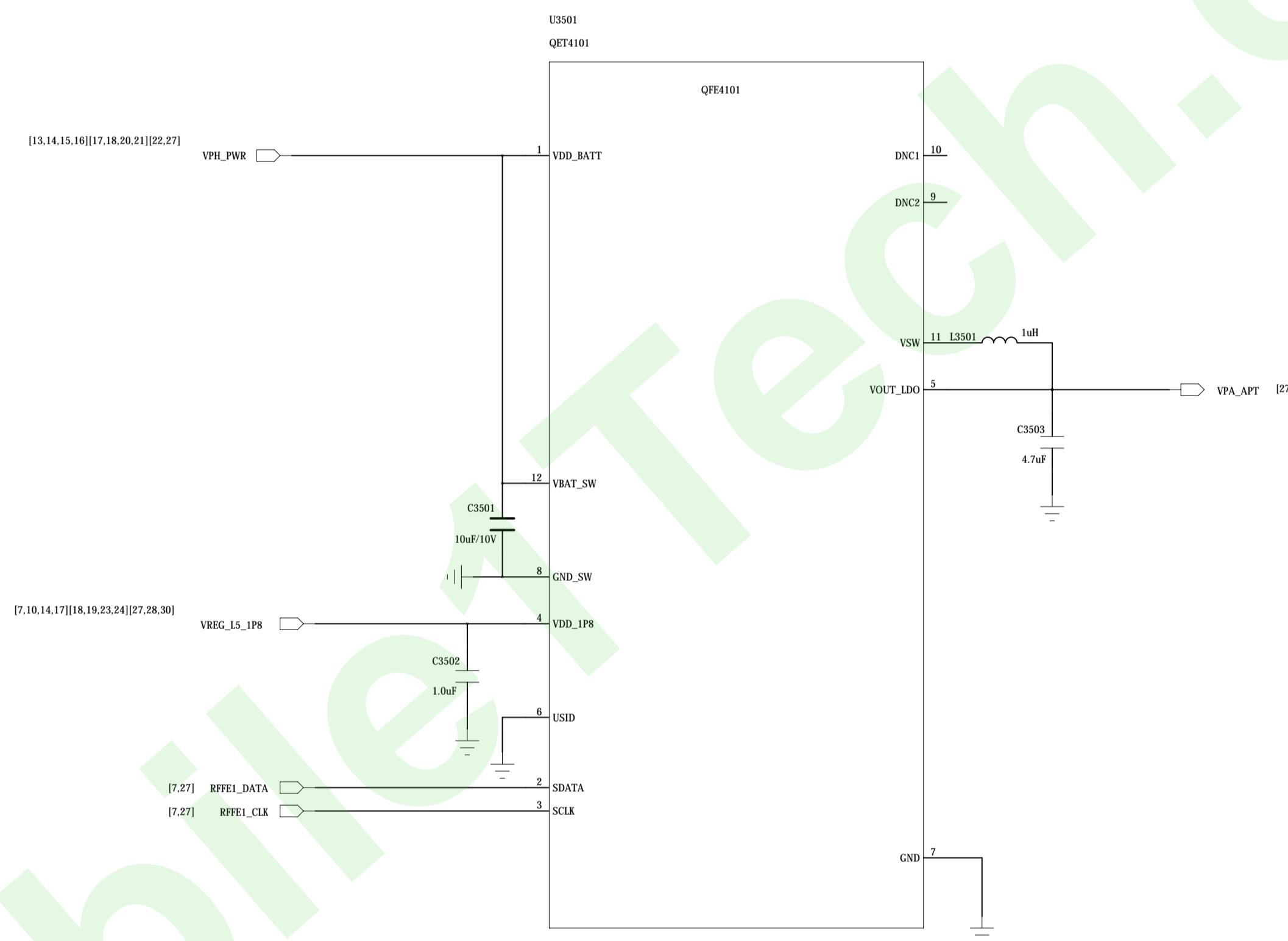

Mobile1Tech.com

COMPANY: <Company Name>		TITLE: 22_DRX Redmi Y3	
CODE: <Code>	SIZE: A0	DRAWING NO: <Drawing Number>	REV: <Revision>
DRAWN: LinMengya	DATE: <Drawn Date>	SCALE: <Scale>	SHEET: 29 of 31
CHECKED: JJJ	DATE: <Checked Date>		

